

YASKAWA

Z1000U HVAC MATRIX Bypass

Low Harmonic Drive Bypass for HVAC Applications

Quick Start Procedure

Type: Z1D1

Models: 208 V: 7.5 to 75 HP
480 V: 7.5 to 350 HP

To properly use the product, read this manual thoroughly and retain for easy reference, inspection, and maintenance. Ensure the end user receives this manual.

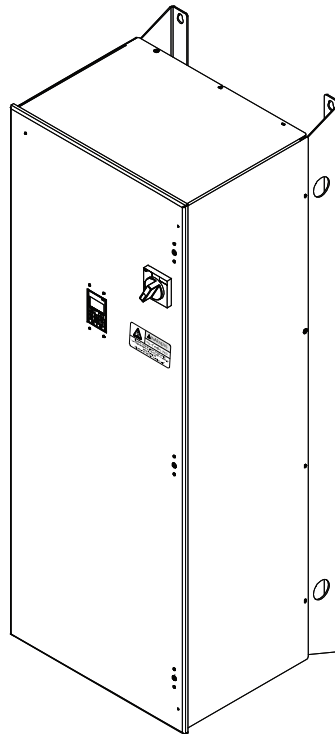

CONTENTS

STEP 1:	<input type="checkbox"/>	Z1000U BYPASS MODEL IDENTIFICATION AND INSTALLATION..	3
STEP 2:	<input type="checkbox"/>	MECHANICAL INSTALLATION.....	4
STEP 3:	<input type="checkbox"/>	CONNECT MOTOR AND LINE POWER.....	5
STEP 4:	<input type="checkbox"/>	ADJUST MOTOR OVERLOAD RELAY AND INPUT BREAKER.....	8
STEP 5:	<input type="checkbox"/>	WIRE INTERLOCK CIRCUITS.....	9
STEP 6:	<input type="checkbox"/>	HOA KEYPAD TUTORIAL	11
STEP 7:	<input type="checkbox"/>	CONFIGURE THE HAND AND AUTO SPEED COMMANDS	12
STEP 8:	<input type="checkbox"/>	VERIFY COMMON PARAMETER SETTINGS.....	17
STEP 9:	<input type="checkbox"/>	CHECK MOTOR ROTATION DIRECTION.....	22
STEP 10:	<input type="checkbox"/>	HAND MODE OPERATION.....	25
STEP 11:	<input type="checkbox"/>	AUTO MODE OPERATION.....	27
STEP 12:	<input type="checkbox"/>	TROUBLESHOOTING.....	30
STEP 13:	<input type="checkbox"/>	BACNET COMMUNICATIONS (OPTIONAL).....	32
STEP 14:	<input type="checkbox"/>	CONNECTION DIAGRAM.....	34

STEP 1

Z1000U Bypass Model Identification and Installation

Safety Symbols in this Document

WARNING!
Read and understand users manual before using this equipment. Failure to follow users instructions may result in serious injury or death.

WARNING!
Hazardous Voltage. Contact may cause electric shock or burn. Turn-off and lock-out system and facility power before servicing.

WARNING!
Stay Clear- Equipment starts automatically. Clear all personnel from equipment, install shields or guards, locate and verify emergency SHUT-OFF is functional. Failure to comply may result in serious injury to personnel.

WARNING!
Improper Operation Sequence. **DO NOT RUN THE MOTOR.** Failure to comply may result in serious injury to personnel.

WARNING!
Do not operate equipment with covers or guards removed. Install or replace cover and/or guards before operation. Failure to comply may result in serious injury to personnel.

This Z1000U Quick Start Procedure serves as general guide to help install, configure and perform test run operation. Refer to Z1000U Bypass Technical Manual No. SIEPYAIZ1D01 for complete instructions and to configure the Z1000U Bypass for each specific installation site.



1.1 Verify the correct Z1000U Bypass model and ratings.

- Locate the Z1000U Bypass nameplate and your order information.
- Verify the Z1000U Bypass Model No: (E) matches the line item(s) on your order, to confirm receipt of the correct model.
- Locate the nameplate of motor that will be connected to the Z1000U Bypass.
- Confirm the motor nameplate Amperage, Voltage, and Frequency (Hz) are within the Output specifications (B) shown on the Z1000U Bypass nameplate.

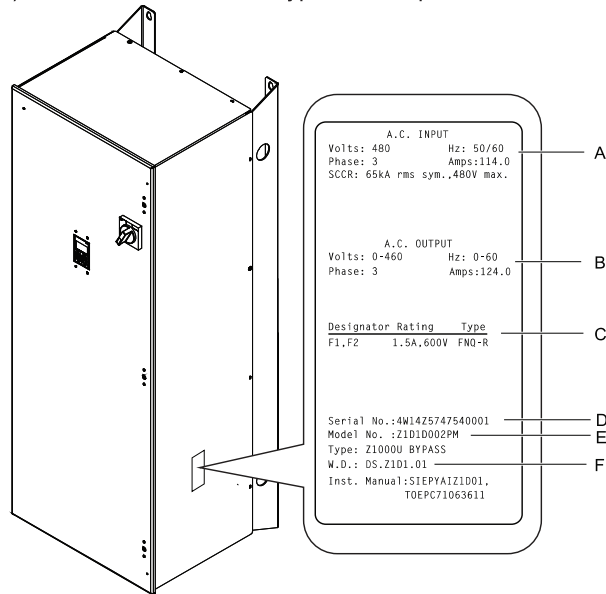

A- Input specifications
B- Output specifications
C- Control transformer fuse specs

D- Serial number
E- Bypass model number
F- Schematic document number

1.2 Verify main power source is adequate by reviewing the Input specifications (A) shown on the Z1000U Bypass nameplate.

STEP 2

□ Mechanical Installation

2.1 Verify installation environment.

Mechanical installation and mounting footprint vary by bypass model. Refer to the Z1000U HVAC Matrix Bypass Technical Manual No. SIEPYAIZ1D01, Chapter 2: Mechanical Installation for mechanical installation details. Ensure the installation conditions are suitable for the Z1000U Bypass to prolong and optimize performance life.

Environment	Conditions
Installation Area	Indoors
Ambient Temperature	-10 to + 40 °C (+14 to +104 °F) NEMA Type 1 Enclosure
Humidity	95% RH or less and free of condensation
Storage Temperature	-20 °C to +60 °C (-4 °F to +104 °F)
Surrounding Area	Install the drive in an area free from: <ul style="list-style-type: none"> • oil mist and dust • metal shavings, oil, water, or other foreign materials • radioactive materials • combustible materials (e.g., wood) • harmful gases and liquids • excessive vibration • chlorides • direct sunlight.
Altitude	Up to 1000 meters without derating. Up to 3000 meters with output current and voltage derating
Orientation	Install the bypass vertically to maintain maximum cooling effects.

2.2 Maintain installation clearances.

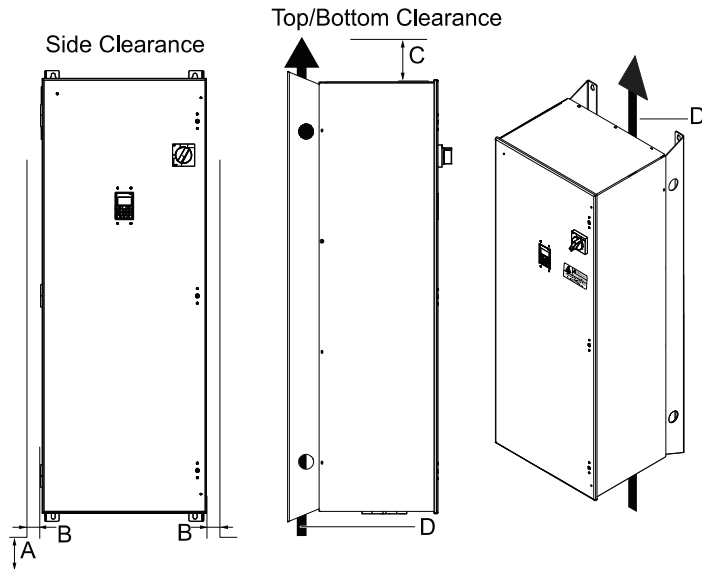

Ensure the back panel is placed against a closed flat surface for proper cooling.

NOTICE: Abnormal Operation. Avoid placing peripheral devices, transformers, or other electronics near the bypass as the noise created can lead to abnormal operation. Take proper steps to shield the bypass from electrical interference if such devices must be used in close proximity to the Bypass.

NOTICE: Equipment Damage. Prevent foreign matter such as metal shavings and wire clippings from falling into the bypass during installation. Failure to comply could result in damage to the bypass. Place a temporary cover over the top of the drive during installation. Remove the temporary cover before bypass start-up, as the cover will reduce ventilation and cause the bypass to overheat.

Models	Minimum Bypass Installation Spacing			
	A	B	C	D
D024 and B011 to B021	152 mm (6.0 in.)	102 mm (4.0 in.)	914 mm (36.0 in.)	Airflow direction
D030 to D074 and B027 to B077		152 mm (6.0 in.)		
D088 to D114 and B096 to B124	165 mm (6.5 in.)			
D143 to D211 and B156 to B414	-	-	127 mm (5.0 in.)	

STEP 3 **Connect Motor and Line Power**



3.1 Open enclosure front covers

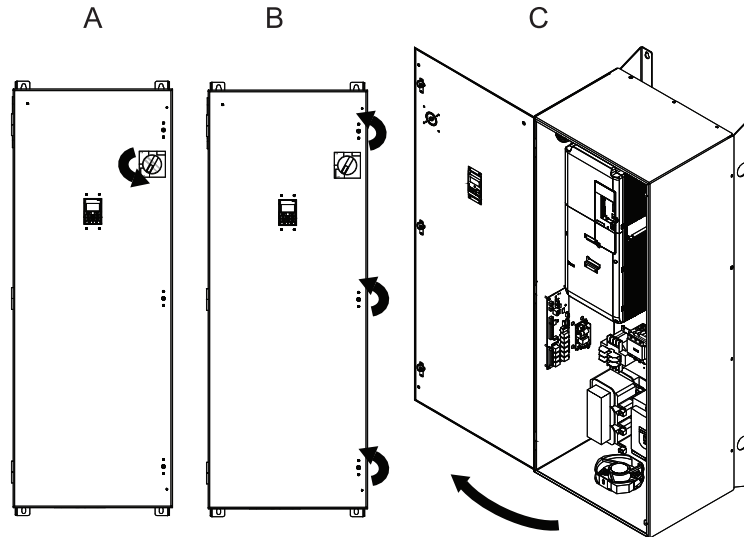

Models D024 to D114 and B011 to B124

- A – Turn circuit breaker to the “OFF” position
- B – Turn the flat head screw fasteners on the cover 1/2 turn counter-clockwise
- C – Swing open door

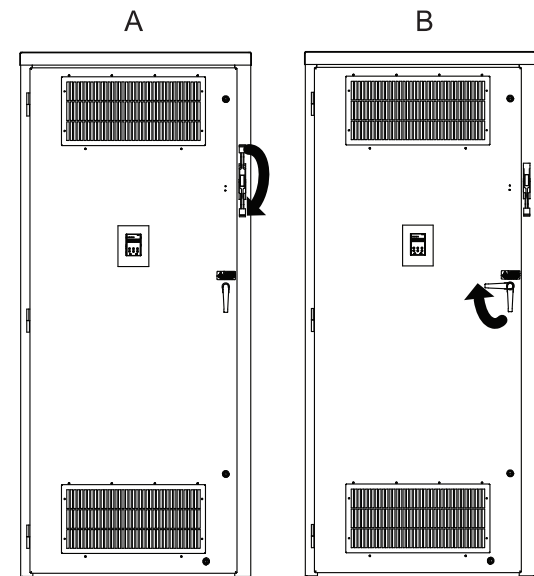

Models D143 to D211 and B156 to B414

- A – Turn circuit breaker to the “OFF” position
- B – Turn the door handle 1/4 turn to the left and open the door (Models B302 to B414 have two doors)

STEP 3 □ Connect Motor and Line Power (continued)

3.2 Select the proper diagram for the model being installed.

WITH POWER OFF, make input power and motor terminal electrical connections.

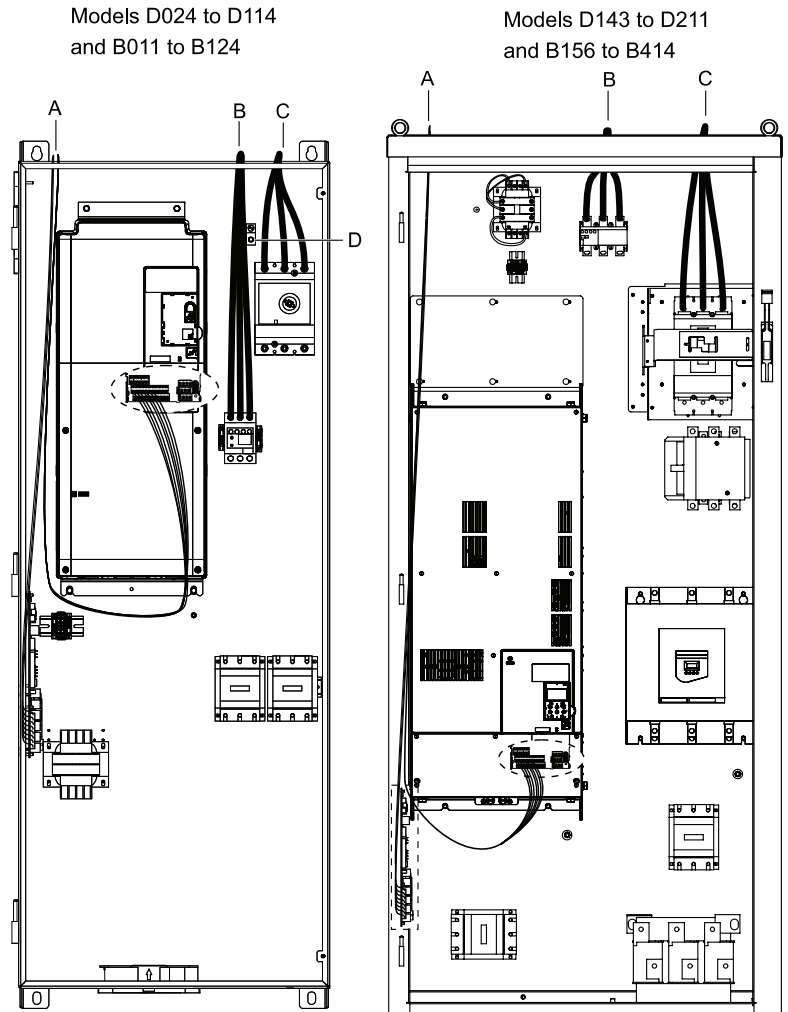

- A – Control, frequency reference, and communications wiring
- B – Motor output circuit
- C – Main input power circuit
- D – Bypass grounding terminal

3.3 Connect building ground circuit to the bypass grounding terminal (D) of the bypass.

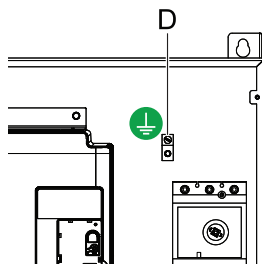

Note: Grounding terminal location varies by model.

STEP
3

□ Connect Motor and Line Power (continued)

3.4 Connect three-phase main input power (C) to the input circuit breaker (L1, L2, L3).

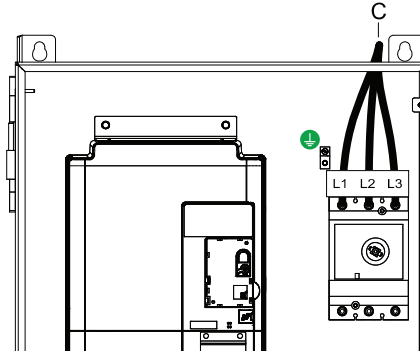

WARNING! Fire Hazard. Do not connect the AC power line to T1, T2, T3 output terminals. Failure to comply could result in death or serious injury by fire as a result of drive damage from line voltage application to output terminals.

3.5 Connect the motor

- Verify the motor leads within the motor junction box are properly connected for the application voltage for dual voltage motors.
- Connect the motor ground wire to the bypass drive ground terminal (D).

Note: Grounding terminal location varies by model.

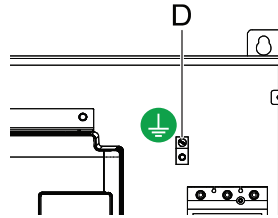

- Connect the motor leads to (B) the bypass motor output circuit terminals, labeled T1, T2, T3.

Note: T1, T2, T3, location varies by model.

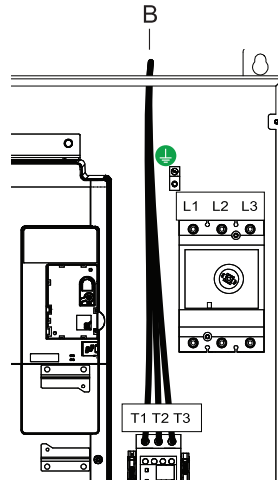

NOTICE: Route motor leads T1, T2, and T3 separate from all other leads to reduce possible interference related issues. Failure to comply may result in abnormal operation of drive and nearby equipment.

NOTICE: Equipment damage. Do not connect phase-advancing capacitors or LC/RC noise filters to the output motor circuit T1, T2, T3. Failure to comply could result in damage to the drive, phase-advancing capacitors, LC/RC noise filters or ground fault circuit interrupters.

STEP 4 **Adjust Motor Overload Relay and Input Breaker**

4.1 Input circuit breaker adjustment

Note: Input breaker illustrations are not representative of all models.

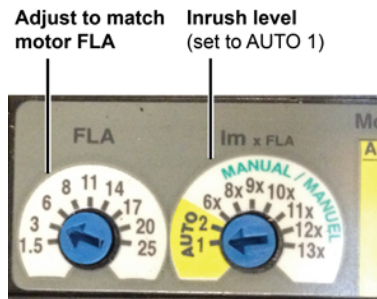
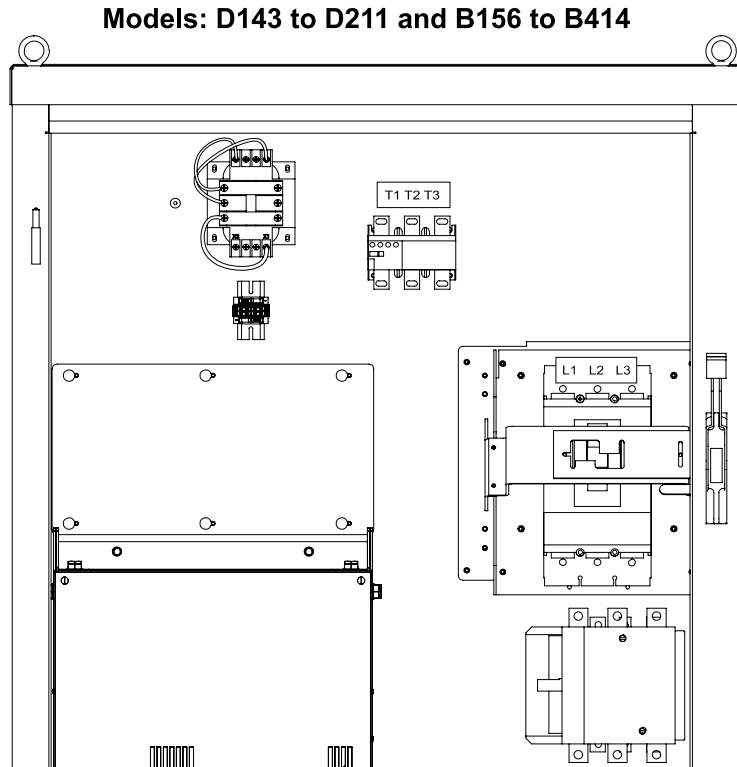
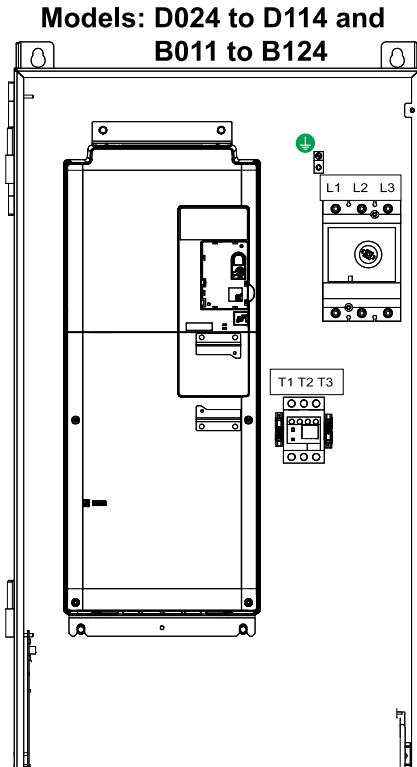

4.1.1 Set input circuit breaker FLA to match motor FLA, and Inrush Level to AUTO 1 as shown.

Input disconnect/Non-fusible

WARNING! Fire Hazard. Install branch circuit protection according to applicable local codes and the requirements listed on the bypass nameplate. Failure to comply could result in fire and damage to the bypass and drive or injury to personnel.

Short Circuit Rating

Bypass models without soft-starter option PW are suitable for use on a circuit capable of delivering not more than 100,000 RMS symmetrical amperes, 208 Vac and 480 Vac.

Bypass models D169 to D211 and B180 to B414 with option PW are also suitable for use on a circuit capable of delivering not more than 100,000 RMS symmetrical amperes, 208 Vac and 480 Vac.

Bypass models D024 to D143 and B011 to B156 with option PW are suitable for use on a circuit capable of delivering not more than 65,000 RMS symmetrical amperes, 208 Vac and 480 Vac.

STEP 4

Adjust Motor Overload Relay and Input Breaker (continued)

4.2 Adjust motor overload relay

Verify that the connected motor full load amperage (FLA) is within the operation range of the motor overload relay (D).



Note:
Motor overload relay
illustrations are not
representative of all
models.

**Models: D024 to D114
and B011 to B124**

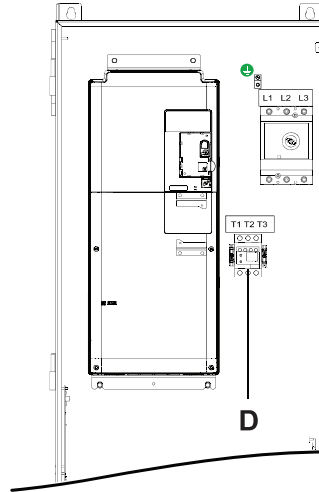

**Models: D143 to D211
and B156 to B414**

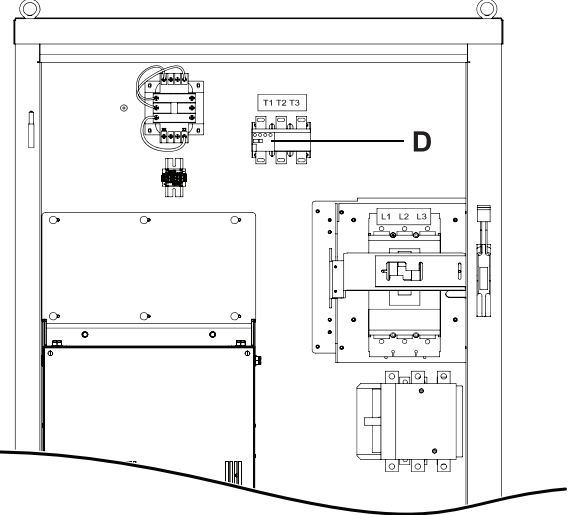

STEP 5

Wire Interlock Circuits

5.1 Install “Run Interlock” and “Run Enable” safety circuit on Bypass Control Board TB2

Note: Refer to wiring illustration on the next page terminal location.

- a. **Install a Run (Auto Mode) switch or jumper at Bypass Control Board terminals TB2 DI-1 to DI-10**
Circuit closure is required for the motor to run in AUTO mode. Utilize an electrical contact from a building automation system (BAS) or other remote controller for auto mode control.
- b. **Install a Run Enable (Safety) switch or jumper at Bypass Control Board terminals TB2 DI-2 to DI-10**
The HOA keypad will display a “Safety Open FB01” fault and prevent bypass operation if this circuit is not closed. Connect safety devices in a normally-closed series circuit, such as: freeze up thermostats, smoke/fire sensors, high pressure limits, temperature limits, or vibration detectors.

Note: **FBO1** Fault will occur if this circuit is not closed.



- c. **Install a BAS interlock switch or jumper at DI-3 to DI-10**
Building Automation System (BAS) Interlock. The HOA keypad will display an “INTRLOCK OPN” fault and prevent drive and bypass operation if this circuit opens. The HOA keypad may also display “BAS llock-open” alarm or “BAS llock TO” if this circuit opens.

Note: **AL02** Fault will occur if this circuit is not closed.



STEP

5

Wire Interlock Circuits (continued)

This figure illustrates locations of the Bypass Control Board terminal blocks.
Note: The Bypass Control Board mounting location varies slightly by model.

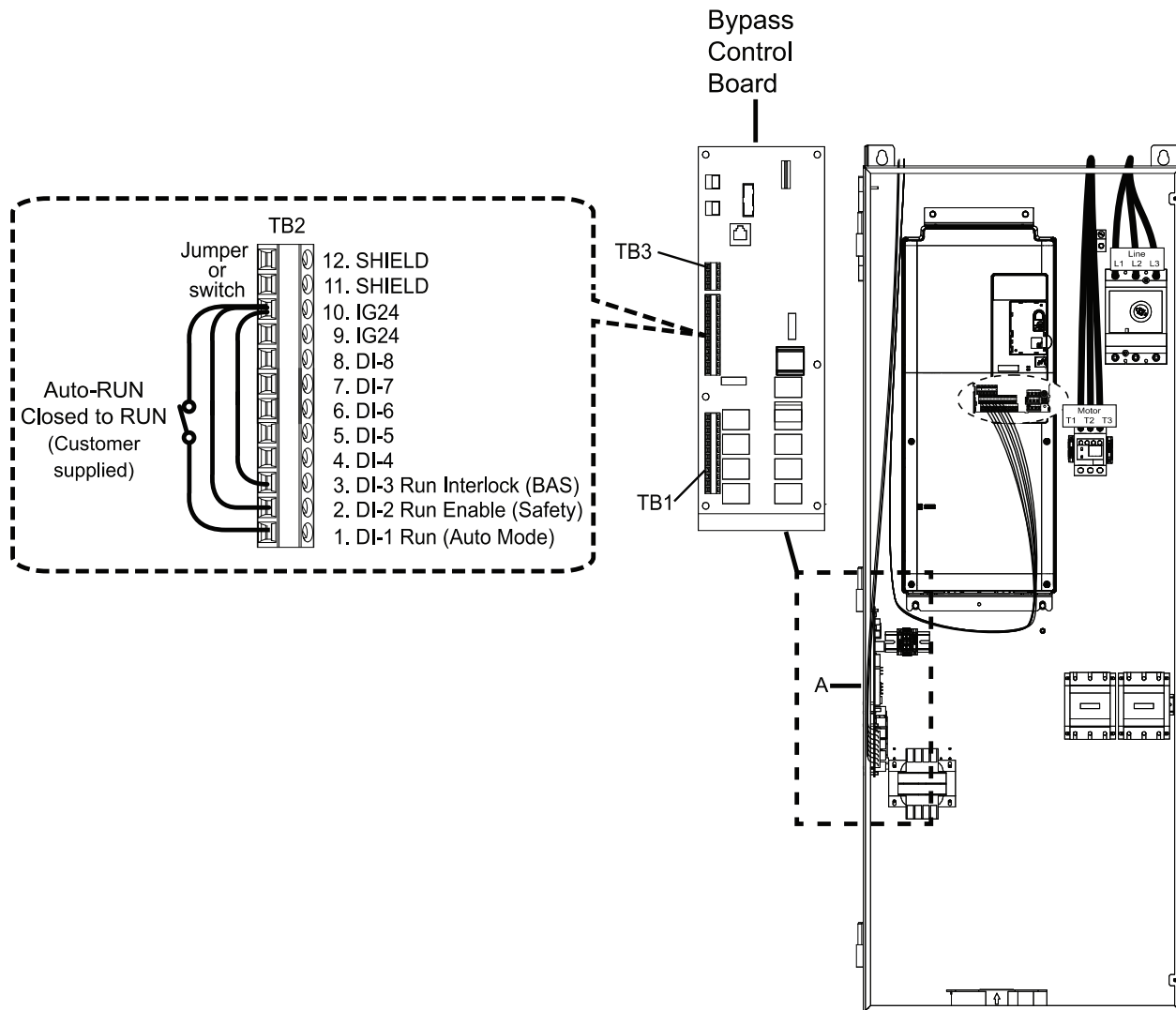

NOTICE: Equipment Malfunction. Separate control circuit wiring from main circuit wiring (terminals R/L1, S/L2, T/L3, p1, n1, U/T1, V/T2, W/T3) and other high-power lines. Improper wiring practices could result in drive malfunction due to electrical interference.

5.1 Initial power application.

Follow these precautions prior to energizing the bypass.









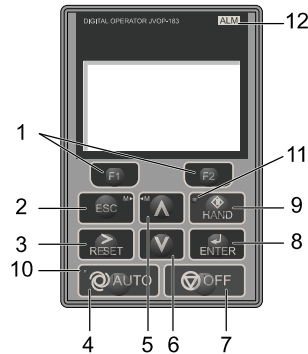



- Remove tools:** Remove all tools and debris is from the enclosure.
- Check wiring:** Verify correct termination of main and motor power connections.
- Check main supply:** Verify correct input voltage at main switch or breaker is present.
- Clear personnel:** Ensure all personnel are clear of drive and motor and motor shaft is free to rotate.
- Locate power off:** Be familiar with emergency power off switch/breaker location.

STEP
6

□ HOA Keypad Tutorial

6.1 Review this tutorial to become familiar with HOA Keypad operation before proceeding.



No.	Display	Key or Indicator Name	Function
1	 	Function F1 (RLY)	Selects Drive Test Mode Note: Applies specifically to drives configured with 3-contactor. Pressing the F1 (RLY) key places the drive in Drive Test Mode. Power is applied to the drive in the bypass mode.
		Function F2 (BYP/DRV)	Toggles selection between Bypass Mode and Drive Mode.
2		ESC	<ul style="list-style-type: none"> Returns to the previous display. Moves the cursor one space to the left. In Drive Mode, repeatedly pressing this button will return to the Frequency Reference display. In Bypass Mode, repeatedly pressing this button will return to the UB-01 "Bypass Current" display. During parameter entry, allows aborting the current edited value and exits the parameter editing mode.
3		RESET	<ul style="list-style-type: none"> Moves the cursor to the right. Resets the bypass or drive to clear a fault situation Certain drive conditions may require pressing the OFF key before the RESET key will clear a fault..
4		AUTO	Selects AUTO mode.
5		Up Arrow	Scrolls up to display the next item, selects parameter numbers, and increments setting values.
6		Down Arrow	Scrolls down to display the previous item, selects parameter numbers, and decrements setting values.
7		OFF Key	If the drive was operating the motor, the motor will stop according to the stopping method selected in b1-03. If the bypass was operating the motor, the bypass contactor opens and the motor coasts to a stop.
8		ENTER	<ul style="list-style-type: none"> Enters parameter values and settings. Selects a menu item to move between displays.
9		HAND	Selects HAND mode.
10		AUTO Light	Lit or flashing while the drive is in AUTO mode.
11		HAND Light	Lit while the drive is in HAND mode.
12		ALARM Light	<ul style="list-style-type: none"> Flashing: Indicates Alarm (minor fault) Solid: Indicates Fault (major fault)

STEP 6

□ HOA Keypad Tutorial (continued)

Display	BYPASS/DRIVE STATUS DISPLAY
DRV (not blinking)	Drive Mode. The bypass will run in Drive Mode when a Run command is present.
DRV (blinking)	Drive Mode, but a condition is making the bypass run in Bypass Mode. Example: Smoke Purge - Bypass Mode
BYP (not blinking)	Bypass Mode. The bypass will run in Bypass Mode when a Run command is present. In a three-contactor bypass, drive input contactor K1 is open and the drive will be powered down.
BYP (blinking)	Bypass Mode with Drive Test Mode set. The bypass will run in Bypass Mode when a Run command is present. In a three-contactor bypass, drive input contactor K1 is closed and the drive is powered on.

Display	BYPASS STATUS DISPLAY
AUTO XFER EN	Running in Auto Transfer, a fault was detected and switched to Bypass Mode.
ENRGY SAVE EN	Running in Energy Savings Mode
MTR STOPPING	Fault is removed but motor is still ramping down.
FAULTED	Fault has been detected causing motor output contactors to open.

Display	BYPASS STATUS DISPLAY
POWERUP	Bypass is powering up.
OFF	No Run command is present and the safety circuit is closed.
WAIT FOR RUN	AUTO mode: -Safety circuit is closed -Bypass waits for Run input.
SAFETY OPEN	The safety circuit input is open.
INTRLOCK OPN	Run command is present, the safety circuit is closed, but the Interlock input is open.
PRE RUN DRIVE	Bypass is running in the Pre-Run State at the programmed frequency for the programmed time.
RUN DRIVE	Running in Drive Mode.
RUN BYPASS	Running in Bypass Mode.
RMOT XFER EN	Running in Remote Transfer.
SMOK PRG BYP	Running in Smoke Purge Bypass.
SMOK PRG DRV	Running in Smoke Purge Drive.

Display	FUNCTION KEY 1 (F1)
HELP	Press F1 to display the Help menu.
<<	Press F1 to scroll the cursor to the left.
HOME	Press F1 to return to the top menu (Frequency Reference).
ESC	Press F1 to return to the previous display.
RLY	Press F1 to select/deselect Drive Test Mode. During Drive Test Mode, power is applied to the drive while in Bypass Mode by forcing the drive input contactor to close (3-contactor bypass only).

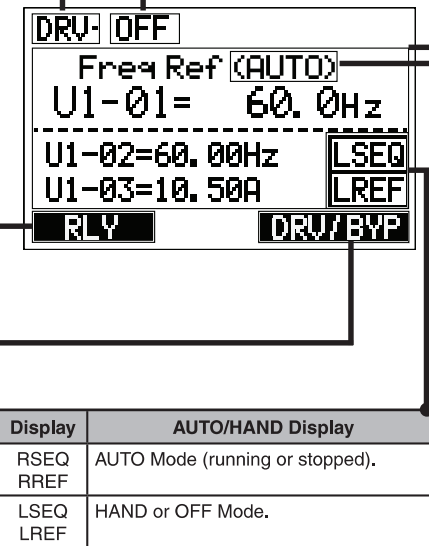

Display	DATA DISPLAY
—	Displays specific data and operation data.

Display	FUNCTION KEY 2 (F2)
DATA	Press F2 to scroll to the next display.
-->	Press F2 to scroll the cursor to the right.
DRV/BYP	Press F2 to toggle selection between Bypass Mode and Drive Mode

Display	AUTO/HAND Display
RSEQ RREF	AUTO Mode (running or stopped).
LSEQ LREF	HAND or OFF Mode.

Display	AUTO/HAND Display
AUTO	AUTO or OFF Mode (running or stopped).
HAND	HAND Mode

STEP 7

□ Configure the HAND and AUTO Frequency Reference

- The HAND and AUTO frequency references can be set independently.
- The factory default for HAND frequency reference originates from the HOA keypad.
- The factory default for AUTO frequency reference originates from drive analog inputs A1 or A2.

7.1 Ensure the HOA keypad cable is firmly connected between the HOA keypad door mounted cable port and communications port CN2 on the bypass controller board.

7.2 Energize the Bypass.



STEP 7









Configure the HAND and AUTO Frequency Reference (continued)







7.3 HAND REF: Set the HAND Frequency Reference.

The factory default for the HAND Frequency Reference is 10.0 Hz.

Note: Skip this step if a test run at 10.0 Hz (approximately 300 rpm on a 4 pole motor) is suitable for the application. The HAND frequency reference is set in parameter Z1-09. Use the following key example to change the frequency reference in HAND mode.

7.4 Example key press procedure.

Step	Key Press	Display
7.4.1	Power-up state 	<pre> DRU-OFF Freq Ref (AUTO) U1-01= 60.00Hz U1-02= 0.00Hz LSEQ U1-03= 0.00 LREF RLV DRU/SVP </pre> <p>NOTE: The Frequency reference screen appears after the drive is energized.</p>
7.4.2		<pre> DRU-OFF Auto-Tuning AUTO HELP DATA </pre>
7.4.3		<pre> DRU-OFF Programming HELP DATA </pre>
7.4.4		<pre> DRU-OFF Quick Setting HELP DATA </pre>
7.4.5		<pre> DRU-OFF Sed Ref Sel Z1-07= 1 *1* Analog Input HOME DATA </pre>
7.4.6		<pre> DRU-OFF Run Cnd Sel Z1-08= 1 *1* Bypass DI HOME DATA </pre>
7.4.7		<pre> DRU-OFF Hand Fref Z1-09= 10.00Hz (0.0~60.0) "10.0Hz" HOME DATA </pre>
7.4.8		<pre> DRU-OFF Hand Fref Z1-09= 0010.0Hz (0.0~60.0) "10.0Hz" </pre>

Step	Key Press	Display
7.4.9		<pre> DRU-OFF Hand Fref Z1-09= 0010.0Hz (0.0~60.0) "10.0Hz" </pre>
7.4.10		<pre> DRU-OFF Hand Fref Z1-09= 0010.0Hz (0.0~60.0) "10.0Hz" </pre>
7.4.11	 or 	<pre> DRU-OFF Hand Fref Z1-09= 0000.0Hz (0.0~60.0) "10.0Hz" </pre>
7.4.12		<pre> Entry Accepted HOME DATA </pre> <pre> DRU-OFF Hand Fref Z1-09= 30.0Hz (0.0~60.0) "10.0Hz" HOME DATA </pre>
7.4.13		<pre> DRU-OFF Freq Ref (AUTO) U1-01= 60.00Hz U1-02= 0.00Hz LSEQ U1-03= 0.00 LREF RLV DRU/SVP </pre>

STEP 7 **Configure the HAND and AUTO Frequency Reference (continued)**

7.5 AUTO REF: Configure the Frequency Reference via Remote Analog Input.



NOTICE: Equipment Damage Tighten terminal screws to specified torque. Failure to comply may result in erroneous operation or damage to the terminal block.

NOTICE: Separate the control circuit wiring from main circuit wiring (terminals R/L1, S/L2, T/L3, p1, n1, U/T1, V/T2, W/T3). Improper wiring practices could result in drive malfunction due to electrical interference.

Insulate shields with tape or shrink tubing to prevent contact with other signal lines and equipment. Improper wiring practices could result in drive or equipment malfunction due to short circuit. Use shielded twisted-pair cables as indicated to prevent operating faults. Improper wiring practices could result in drive or equipment malfunction due to electrical interference.

Connect the cable shield to the appropriate ground terminal. Improper equipment grounding could result in drive or equipment malfunction or nuisance trips. The shield ground wire (F) is typically connected at one end, at the signal source to avoid ground loops. Use terminal (Drive Terminal Board TB5) if a shield ground connection is required at the drive to mitigate noise issues in special cases.

7.6 Connect remote frequency reference wires to the drive control circuit terminals.

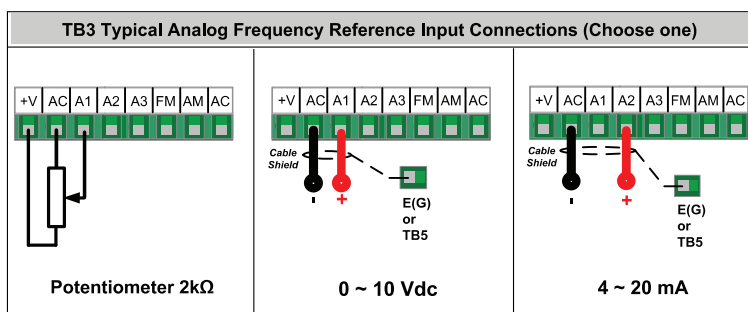
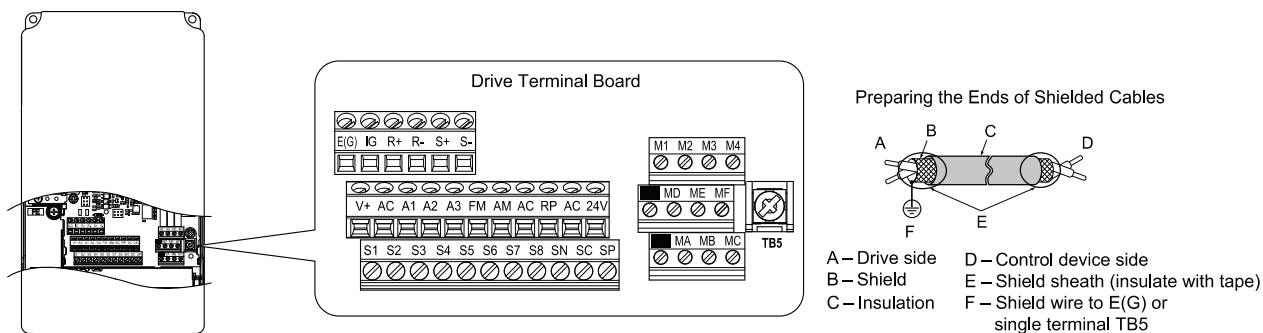

No.	Terminal Name (Function)	Signal Types
+V	Power supply for analog inputs	10.5 Vdc (maximum allowable current 20 mA)
A1	Multi-function analog input 1	<ul style="list-style-type: none"> (Default: 0 to 10 Vdc) Other supported signal types: <ul style="list-style-type: none"> -10 to 10 Vdc, input impedance: 20 kΩ 4 to 20 mA, 0 to 20 mA (input impedance: 250 Ω) Voltage or current input must be selected by jumper S1 and H3-01.
	Note: Used for 0 to 10 V AUTO frequency reference	
A2	Multi-function analog input 2	<ul style="list-style-type: none"> (Default 4 to 20 mA) Other supported signal types: <ul style="list-style-type: none"> 0 to 20 mA input impedance: 250 Ω 0 to 10 Vdc, -10 to 10 Vdc, input impedance: 20 kΩ Voltage or current input must be selected by jumper S1 and H3-09.
	Note: Used for 4 to 20 mA AUTO frequency reference	
AC	Frequency reference common	0 V
E (G)	Ground for shielded lines	—

STEP
7

□ Configure the HAND and AUTO Frequency Reference (continued)

7.7 Route signal wiring.

Properly route signal wiring to reduce coupling of external noise to signal wiring. Attempt to route and secure signal wiring at least one inch away from power wiring for parallel routing. Route control wiring a right angles when crossing power wiring and control wires within the drive enclosure.

Models D024 to D114 and B011 to B124 Models D143 to D211 and B156 to B414

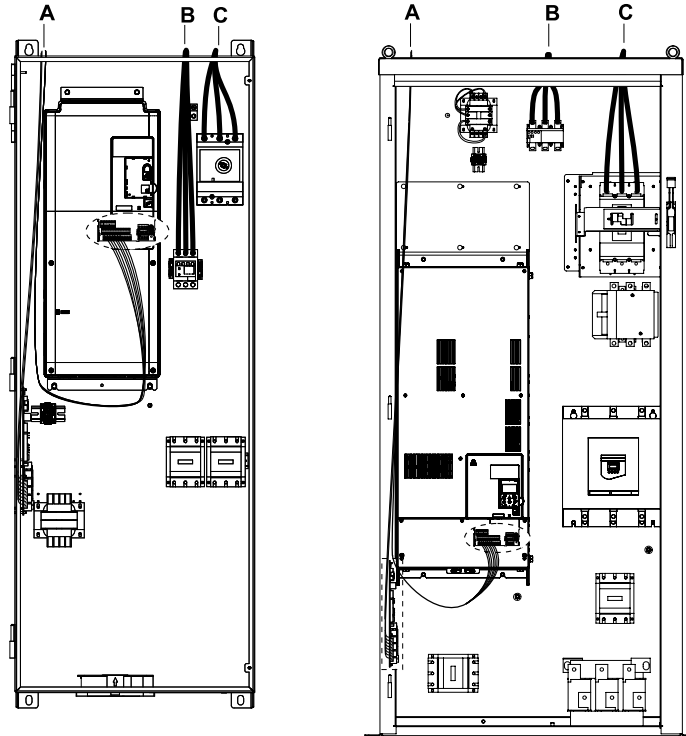

A - Control, frequency reference, and communications wiring

**B - Motor output circuit
C - Main input circuit**

7.8 Verify or set Jumper S1 on the drive to match the frequency reference signal type.

Confirm Jumper S1 on the drive (A1,A2, Volt/Current Selection) is set to match the frequency reference signal type, either voltage (V) or current (I) for Z1000U terminals TB3 - A1 and A2.

- Factory default setting of TB3 - terminal A1 is 0 - 10 Vdc/100%.
- Factory default setting of TB3 - terminal A2 is 4 - 20 mA/100%.

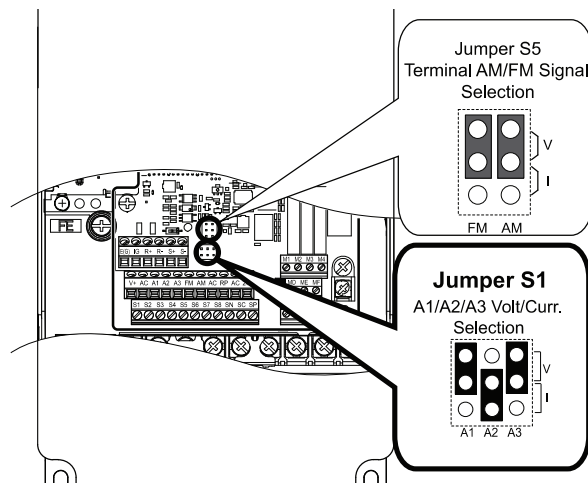

STEP 7 **Configure the HAND and AUTO Frequency Reference (continued)**

7.9 Apply power to the bypass.

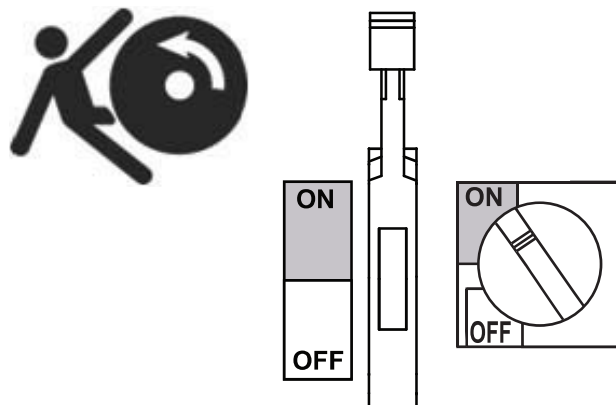

7.10 Confirm the drive is configured to accept an analog frequency reference signal in AUTO Mode (Parameter Z1-07).

Confirm parameter Z1-07 is set to 1 (Analog Input) when using an analog frequency reference signal (0~10 V or 4~20 mA)

Step	Key Press	Display
7.10.1	Power-up state, NOTE: The Frequency reference screen automatically appears immediately after the drive is energized.	<pre> DRU-OFF Freq Ref (AUTO) U1-01= 60.00Hz U1-02= 0.00Hz LSEQ U1-03= 0.0A LREF RLV DRU/BYP </pre>
7.10.2		<pre> DRU-OFF Auto-Tuning AUTO HELP DATA </pre>
7.10.3		<pre> DRU-OFF Programming HELP DATA </pre>
7.10.4		<pre> DRU-OFF Quick Settings HELP DATA </pre>
7.10.5		<pre> DRU-OFF Spd Ref Sel Z1-07= 0 *0* Operator HOME DATA </pre>

Step	Key Press	Display
7.10.6		<pre> DRU-OFF Spd Ref Sel Z1-07= 0 *0* Operator "0" </pre>
7.10.7	 or 	<pre> DRU-OFF Spd Ref Sel Z1-07= 1 *1* Analog Input "1" </pre>
7.10.8		<pre> Entry Accepted HOME DATA </pre> <pre> DRU-OFF Spd Ref Sel Z1-07= 1 *1* Analog Input HOME DATA </pre>
7.10.9	 2x	<pre> DRU-OFF Freq Ref (AUTO) U1-01= 60.00Hz U1-02= 0.00Hz LSEQ U1-03= 0.0A LREF RLV DRU/BYP </pre>

STEP
8

□ Verify Common Parameter Settings







8.1 Use this step-by-step example to check or adjust common parameters.



Step	Key Press	Description	HOA Display/Result
Main Menu Selections			
8.1.1	 2x	Confirm power-up state. Press ESC multiple times to go to the HOME screen. The HOME screen showing that the bypass in Drive mode and currently OFF. HOA display shows that the bypass is in "AUTO" mode with the frequency reference displayed.	
8.1.2		Press up arrow one time to display the Monitor Menu. All available drive and bypass monitors can be viewed from this menu.	
Modified Constants			
8.1.3		Press up arrow one time to display the Modified Constants Menu. This menu lists parameters modified by the user that differ from factory default settings.	
8.1.4		Press up arrow one time to display the Quick Settings Menu. These are the most common parameters used for initial drive start-up.	
8.1.5		Press up arrow one time to display the Programming Menu. All available drive and bypass parameters are accessed through this menu.	
8.1.6		Press up arrow one time to display the Auto-Tuning Menu. The Auto-Tuning function tunes the drive to the characteristics of the connected motor. Auto-Tuning is essential if bi-directional Speed Search is required and enabled for the application.	
Parameter Adjustment			
8.1.7	 or 	Press up or down arrow until the Quick Settings Menu or Programming Menu screen is displayed.	

STEP
8

Verify Common Parameters (continued)





Step	Key Press	Description	HOA Display/Result
8.1.8		Press ENTER to access and adjust parameters in the Quick Settings menu or scroll to the Programming menu to adjust Programming parameters. Refer to the Common Parameters table for a list of common parameters and set values to meet application needs.	<pre> DRU-OFF Spd Ref Sel ----- Z1-07= 0 *0* Operator HOME DATA </pre>
8.1.9		Press ENTER to change the parameter value using the arrow keys.	<pre> DRU-OFF Spd Ref Sel ----- Z1-07= 0 *0* Operator "0" ← → </pre>
8.1.10	 or 	Use the UP or DOWN arrows to change the parameter value.	<pre> DRU-OFF Spd Ref Sel ----- Z1-07= 1 *1* Analog Input "0" ← → </pre>
8.1.11		Press ENTER to save the value. "Entry Accepted" will be displayed on the HOA keypad.	<pre> Entry Accepted HOME DATA </pre>
8.1.12		Press the UP arrow to scroll to the next parameter to continue set-up of Common Parameters in the next table.	<pre> DRU-OFF Run Cnd Sel ----- Z1-08= 1 *1* Bypass DI HOME DATA </pre>
8.1.13		Press the F1 "Home" key to exit and return to operation when set-up of Common Parameters is completed.	<pre> DRU-OFF Freq Ref (AUTO) U1-01= 60.00Hz U1-02= 0.00Hz LSEQ U1-03= 0.0A LREF RLY DRU/BYP </pre>

STEP
8

Verify Common Parameters (continued)

8.2 Common Parameter Settings

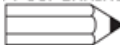
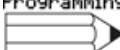
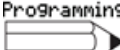
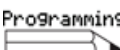
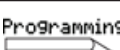
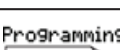
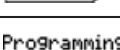

Use the parameter adjustment procedure in section 8.1 to view or modify any of these parameters.

Parameter	HOA Menu Access	Default Value	Description HOA Display	Comments
Basic Operation				
b1-03	Quick Setting 	1	Stopping Method Selection Stopping Method	0: Ramp to Stop 1: Coast to Stop 2: DC Injection Braking to Stop 3: Coast with Timer
b3-01	Programming 	0	Speed Search Selection at Start SpdSrch at Start	0: Disabled 1: Enabled
b3-24	Programming 	2	Speed Search Method Selection SpdSrch Method	1: Speed Estimation 2: Current Detection
C1-01	Programming 	30.0 s	Acceleration Time 1 Accel Time 1	Sets the time to accelerate from 0 to maximum frequency.
C1-02	Programming 	30.0 s	Deceleration Time 1 Decel Time 1	Sets the time to decelerate from maximum frequency to 0.
d2-01	Programming 	100.0%	Frequency Reference Upper Limit Ref Upper Limit	Sets the frequency reference upper limit as a percentage of the maximum output frequency.
d2-02	Programming 	0.0%	Frequency Reference Lower Limit Ref Lower Limit	Sets the frequency reference lower limit as a percentage of the maximum output frequency.
L5-01	Programming 	0	Number of Auto Restart Attempts Num of Restarts	Sets the number of times the drive may attempt to restart after a selection of faults.
Z1-05	Programming 	0	Auto Transfer to Bypass Upon Drive Fault Auto Xfr Byp Flt	Operation will switch to Bypass mode when the drive is running and a drive fault occurs. Operation will switch back to Drive mode when the fault is cleared. 0: Disable 1: Enable
Z1-06	Programming 	0	Power-Up Mode Power-Up	Determines the mode of the Bypass Control upon power-up. 0: OFF 1: AUTO-DRIVE 2: HAND-DRIVE 3: AUTO-BYPASS 4: HAND-BYPASS
Z1-07	Quick Setting 	1	Speed (Frequency) Reference Select Spd Ref Sel	Determines the source of the Frequency Reference. 0: Operator 1: Analog Input 2: Bypass Serial 3: Option Board (CN5)

STEP



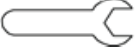
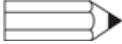
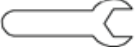
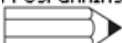
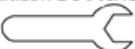

8

Verify Common Parameters (continued)

Parameter	HOA Menu Access	Default Value	Description HOA Display	Comments
Z1-08	Quick Setting 	1	Run Command Select Run Cmd Sel	Determines the source of the Auto Mode Run command used by the Bypass Controller. 0: Operator 1: Bypass Controller Digital Input 2: Bypass Serial 3: Option Board (CN5)
Z1-09	Quick Setting 	10.0 Hz	HAND Mode Frequency Reference Hand Fref	This is the frequency reference used when the Drive is running in HAND mode.
Z1-37	Quick Setting 	0	Set Time Set Time	Changes the LCD display to time setting to set the Real Time Clock. 0: Normal display 1: Set date and time 2: Reset time
Motor				
E1-03	Programming 	F	V/f Pattern Selection V/F Selection	0: 50 Hz, Constant torque 1 1: 60 Hz, Constant torque 2 2: 50 Hz, Constant torque 3 (50 Hz base) 3: 72 Hz, Constant torque 4 (60 Hz base) 4: 50 Hz, Variable torque 1 5: 50 Hz, Variable torque 2 6: 60 Hz, Variable torque 3 7: 60 Hz, Variable torque 4 8: 50 Hz, High starting torque 1 9: 50 Hz, High starting torque 2 A: 60 Hz, High starting torque 3 B: 60 Hz, High starting torque 4 C: 90 Hz (60 Hz base) D: 120 Hz (60 Hz base) E: 180 Hz (60 Hz base) F: Custom V/f Note: E1-05 Max Voltage setting defines the V/f pattern for settings 0 thru E..
E2-01	Quick Setting 	Model Dep. Amps	Motor Rated Current Motor Rated FLA	Sets the motor nameplate full load current in amps. Automatically set during Auto-Tuning.
E2-03	Programming 	Model Dep. Amps	Motor No-Load Current No-Load Current	Sets the no-load current for the motor. Automatically set during Auto-Tuning.
Network Communication				
Note: Cycle power after changing network communication parameters (Z3-XX).				
Z3-01	Quick Setting 	3	Serial Communications Protocol Select Serial Protocol	Selects the bypass serial communications protocol. 0: Modbus 1: N2 2: P1 3: BACnet

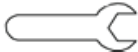
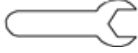
STEP
8

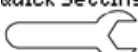
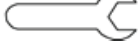
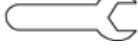
Verify Common Parameters (continued)

Parameter	HOA Menu Access	Default Value	Description HOA Display	Comments
Z3-02	Quick Setting 	1	Serial Communications Node Address Select Node Address	Selects the bypass serial communications node address.
Z3-03	Quick Setting 	3	Serial Communications Baud Rate Select Baud Rate	Selects the bypass serial communications speed. 0: 1200 1: 2400 2: 4800 3: 9600 4: 19200 5: 38400 6: 57600 7: 76800 8: 115200
Z3-04	Quick Setting 	0	Serial Communications Parity Select Parity	Selects the bypass serial communications parity. 0: No Parity 1: Even Parity 2: Odd Parity
Z3-05	Quick Setting 	1	Serial Communications Fault Select Fault Select	Selects the action to take when a serial communications fault is detected. 0: Ignore. A serial communications loss will result in no action being taken. 1: Alarm only. 2: Fault with EF0. An EF0 will be sent to the drive. If running in Bypass, the bypass contactor will NOT open and the motor will keep running. 3: Fault with EF0 and Open Contactors. An EF0 fault will be sent to the drive and the bypass contactor (K3) will be opened. 4: Alarm and run at preset speed set in Z3-10. Display AL14 alarm on Operator
Z3-06	Quick Setting 	2.0 s	Serial Communications Fault Time Select Fault Time	Sets the time allowed to elapse since receiving serial communications before triggering a communications fault. A setting of 0.0 s will never time out.
Z3-07	Quick Setting 	5 ms	Serial Communications Receive to Transmit Wait Time Rx to Tx Wait	Sets the time to delay a serial communications response to a serial communications command. This parameter will only appear when Z3-01 = 0, 1, or 2.
Z3-08	Quick Setting 	1 (Hex)	BACnet Device Object Identifier 0 BAC Dev ID0	BACnet only. Sets the least significant word of 22-bit virtual address. This parameter appears when Z3-01 = 3.
Z3-09	Quick Setting 	0 (Hex)	BACnet Device Object Identifier 1 BAC Dev ID1	BACnet only. Sets the most significant word of 22-bit virtual address. This parameter will appear only when Z3-01 = 3.







STEP

9

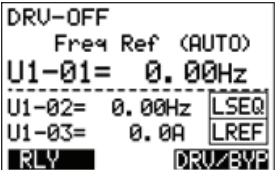
□ Check Motor Rotation Direction

9.1 Verify proper motor rotation direction using the HOA keypad.

The motor must operate in the same rotation direction during both drive and bypass operation to prevent equipment damage. These steps are necessary to configure motor rotation prior to placing the Bypass into service.

Step	HOA Key Press	Description	HOA Display/Result
9.1.1	 2x	CHECK Motor Rotation (DRIVE) Press the ESC key multiple times to return the the Home screen and operation mode.	
9.1.2		 Press HAND to give the drive a Run command from HAND mode. The HAND LED will light and the motor will rotate at the value set to parameter Z1-09 (10 Hz default).	
9.1.3		Ensure the motor is rotating in the correct direction and that no faults or alarms occur. Press OFF. The HAND light turns OFF and the motor coasts to stop. Proceed to STEP 9.1.5 Check Motor Rotation (BYPASS), if motor rotation using DRIVE is correct. Otherwise, proceed to STEP 9.1.4 if motor rotation in DRIVE is NOT correct.	







STEP 9

□ Check Motor Rotation Direction (continued)

Step	HOA Key Press	Description	HOA Display/Result
9.1.4		<p>CORRECTING Motor Rotation (DRIVE)</p> <p>Follow sub-steps a. thru f. below to correct motor rotation direction in DRIVE mode.</p> <ol style="list-style-type: none"> De-energize/turn OFF and lock out the MAINS power supply to the bypass. Turn off power on the front of the bypass and open the cabinet. Verify that there is no power present in the bypass. Exchange the wires connected to terminals T1 and T2 where the motor leads are connected at the motor output circuit. Tighten all connections. Return to STEP 9.1.1 to verify proper motor rotation in DRIVE. <p>DANGER! Shock Hazard. De-energize and lock-out MAIN power supply to the bypass before contacting motor leads.</p>	

Step	HOA Key Press	Description	HOA Display/Result
9.1.5		<p>CHECK Motor Rotation (BYPASS)</p> <p>WARNING! Clear debris, tools, and wire clippings from the bypass enclosure before applying power.</p> <p>Remove lock-out/tag-out, and energize the MAINS branch circuit supply to the bypass.</p> <p>Re-install all covers and close enclosure doors.</p>	
9.1.6		<p>Apply power to the bypass.</p>	
9.1.7		<p>Press F2 to toggle to the Bypass Mode.</p> <p>The keypad display should show BYP-OFF if the device is ready for Bypass operation.</p>	

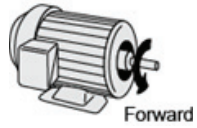
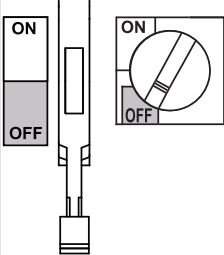
STEP 9 Check Motor Rotation Direction (continued)

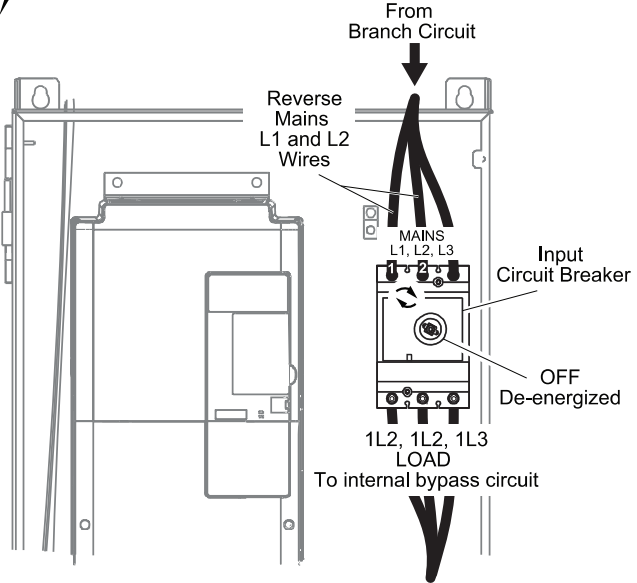







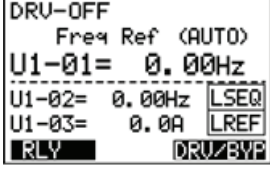

Step	HOA Key Press	Description	HOA Display/Result
9.1.8	 then 	 Press HAND then quickly press OFF within 1 second. The motor will briefly spin under line power. Observe the motor and verify correct rotation direction. Verify no faults or alarms occur. The HAND LED turns OFF and the motor coasts to stop. Proceed to STEP 10.1 if motor rotation in BYPASS Mode is correct. Otherwise, proceed to STEP 9.1.9 if motor rotation in BYPASS is NOT correct.	 
9.1.9		<p>CORRECTING Motor Rotation (BYPASS)</p> <p>Follow sub-steps a. thru f. below to correct motor rotation direction in BYPASS mode.</p>  <ol style="list-style-type: none"> De-energize/turn OFF and lock out the MAINS power supply to the bypass. Turn off power on the front of the bypass and open the cabinet. Verify that there is no power present in the cabinet. Exchange the wires connected to terminals L1 and L2 where the input power is connected at the input circuit breaker. Tighten all connections. Return to STEP 9.1.5 to verify proper motor rotation in BYPASS. <p>DANGER! Shock Hazard. De-energize and lock-out MAIN branch circuit power supply to the bypass before contacting conductors.</p> 	

STEP
10

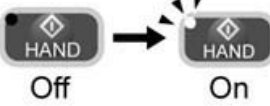
Hand Mode Operation

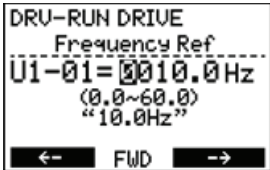

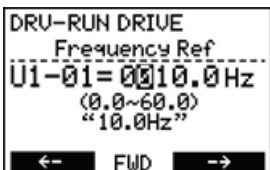

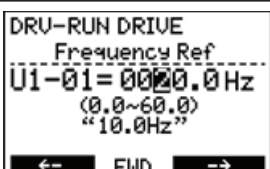

10.1 Perform a test run in HAND mode by following these steps using the HOA keypad.

Note: The safety circuit must be satisfied before the bypass will run in HAND mode. See section 5.1.b for details.

Step	HOA Key Press	Description	HOA Display/Result
10.1.1	 2x	Press the ESC key multiple times to return to the Home screen and operaton mode.	
10.1.2		Prepare to initiate an emergency stop during the test run. Press HAND to give the drive a Run command from HAND mode.  The HAND LED will light and the motor will rotate at the value set to parameter Z1-09 (10.00 Hz factory default). Optional: Refer to Step 7.3 for the procedure to change the HAND frequency reference to a value other than the factory default.	 
10.1.3		Optional STEP: Change speed to 30.00Hz with drive running at 10.00 Hz in HAND mode. Press ENTER	
10.1.4	 x 2	Press RESET twice to move cursor to right.	
10.1.5	 or 	Use UP or DOWN arrow to change the parameter value.	

STEP
10

Hand Mode Operation (continued)

Step	HOA Key Press	Description	HOA Display/Result
10.1.6		Press ENTER to save the value. "Entry Accepted" will be displayed on the HOA keypad.	
10.1.7	 x 2	Press ESC twice to return to operation screen.	
10.1.8		Press OFF to stop the drive.	
10.1.9	–	End. Test run in HAND mode completed.	–

STEP 11 **Auto Mode Operation**

11.1 Prepare for a test run in AUTO mode by performing these steps.

AUTO mode operation operates the motor by providing the Z1000U Bypass with customer supplied, remote RUN and Speed Reference commands. Items a. thru e. below are required to operate the Z1000U bypass in AUTO mode:

- a. RUN Command (AUTO): RUN command, customer supplied. (STEP 5.1.a)
- b. Interlock circuits: 2 each, customer supplied. (STEPS 5.1.b and 5.1.c)
- c. Frequency Reference (AUTO): Reference source, customer supplied. (STEP 7.5)
- d. Common parameters are programmed. (STEP 8)
- e. Motor rotation direction in DRIVE and BYPASS operation modes are verified. (STEP 9)

11.2 Confirm these remote AUTO circuits are connected to the Z1000U Bypass to prepare to perform a test run in AUTO mode. AUTO circuits are customer supplied.

- Frequency Reference (AUTO) at Drive Control Board A1:
 - TB3-A2 (signal) to AC (common) 4-20 mA. Parameter H3-09 = 2. (Factory setting), or
 - TB3-A1 (signal) to AC (common) 0-10 Vdc. Parameter H3-01 = 0. (Factory setting)
- RUN Command (AUTO): AUTO RUN command by contact closure Bypass Control Board TB2-10 to TB2-1.

AUTO Speed Command (Customer supplied)

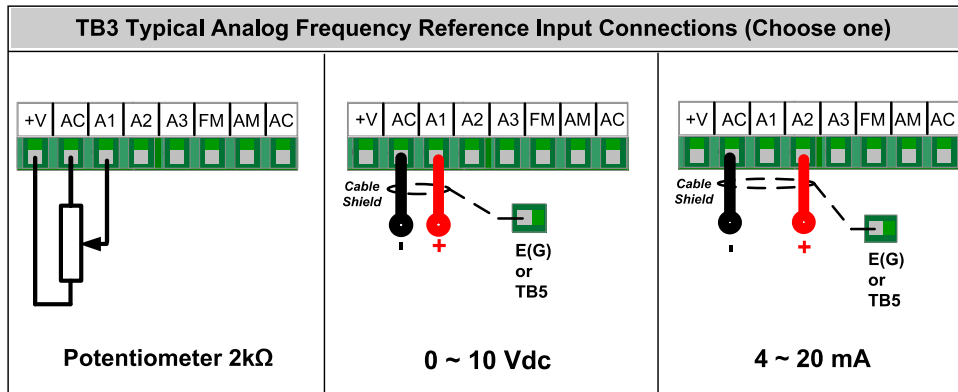



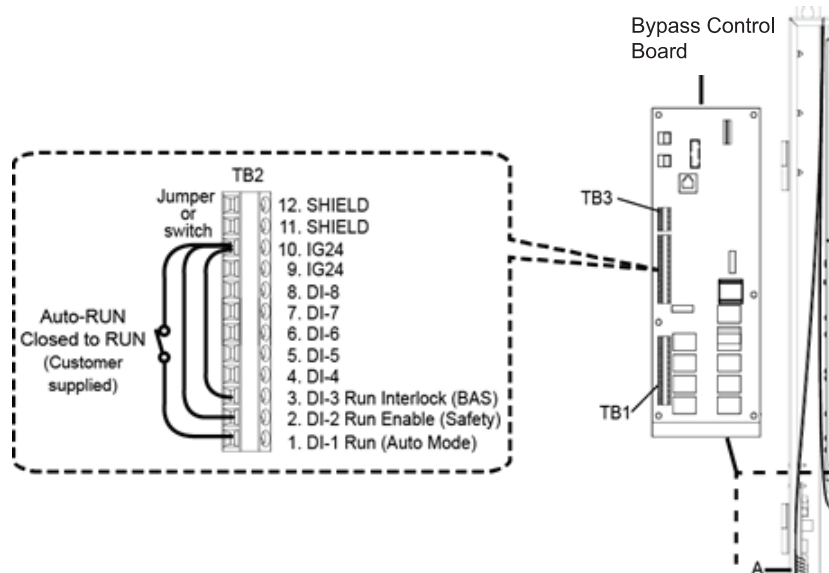



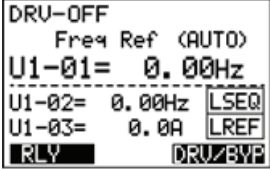

AUTO RUN Command (Customer supplied)



STEP 11 Auto Mode Operation (continued)

11.3 Perform a test run in AUTO mode by following these steps using the HOA keypad.

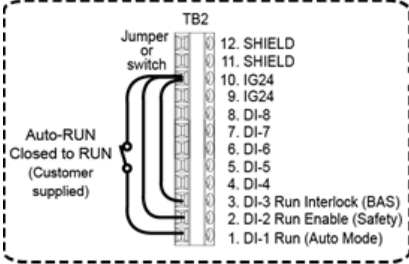
Step	HOA Key Press	Description	HOA Display or Result
11.3.1	 2x	Press the ESC key multiple times to return to the Home screen and operation mode.	
11.3.2		To initiate an emergency stop during the test run, press the OFF key or remove main power to the Z1000U Bypass cabinet.  Press the AUTO button to place the bypass into AUTO mode.	  AUTO Mode  WAIT FOR RUN is displayed and AUTO key LED flashes if AUTO Mode is active but AUTO Run Command is not closed TB2-1 to 10.  AUTO Mode
11.3.3	RUN Command (AUTO)	 Close contact TB2-1 to 10 on the Bypass Control Board. The Z1000U Bypass will run the motor to the AUTO Frequency Reference supplied to TB3-A1 or A2.	



STEP
11

Auto Mode Operation (continued)

Step	HOA Key Press	Description	HOA Display or Result
11.3.4	Frequency Reference (AUTO)	<p>Verify the Frequency Reference* is present at drive Drive Control Board A1 using one of the connection methods shown at the right.</p> <ul style="list-style-type: none"> 4-20 mA: TB3-A2 (signal) to AC (common). Parameter H3-09. (Factory setting) 0-10 Vdc: TB3-A1 (signal) to AC (common). Parameter H3-01. (Factory setting) <p>* Customer supplied</p>	<p>TB3 Typical Analog Frequency Reference Input Connections (Choose one)</p> <p>Potentiometer 2kΩ 0 ~ 10 Vdc 4 ~ 20 mA</p>
11.3.5		Press OFF to stop the drive.	<p>On Off</p>
11.3.6	—	End. Test run in AUTO mode completed.	—

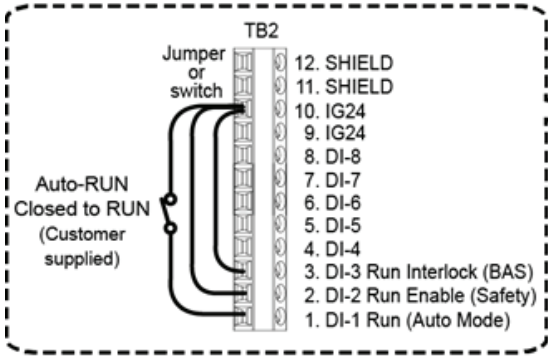

STEP 12 Troubleshooting

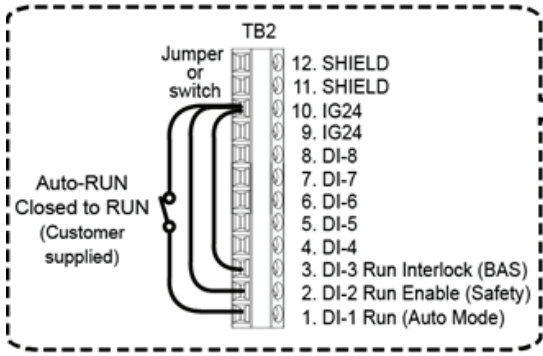
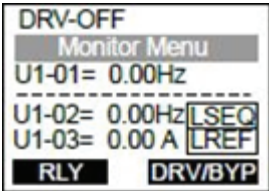
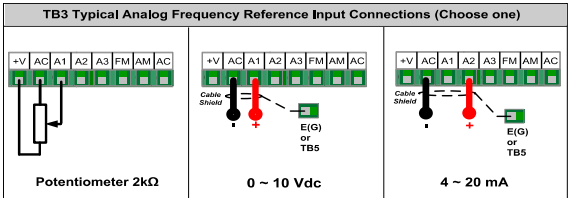
11.3 This section provides information to assist in solving common problems that may occur during test run operation.

Problem/Symptom	Solution
<p>AL02 Fault in HOA Keypad - BAS interlock Open</p> 	<p>Bypass Control Board terminal block TB2-3 to 10 is open. Close contact TB2-3 to 10.</p> 
<p>FB01 Fault in HOA Keypad – Run Enable/Safety Fault</p> 	<p>Bypass Control Board terminal block TB2-2 to 10 is open. Close contact TB2-2 to 10.</p> 
<p>Drive Will Not accelerate the motor to speed.</p> <p>U1-01 on HOA keypad indicates 0.00 Hz. The drive is not receiving a frequency reference.</p> 	<p>If the desired reference source is ANALOG: Verify Z1-07 = 1 (Speed Reference Select is set to Analog Input) and verify analog signals at terminals.</p> <p>If the desired reference source is DIGITAL: Verify Z1-07 = 0 (Speed Reference Select set to Operator) and Z1-09 = Fref (HAND Mode Drive Speed Reference) is a non-zero value. Refer to the Bypass Technical Manual for other reference sources, such as serial communications or PID.</p> 

STEP
12

Troubleshooting (continued)

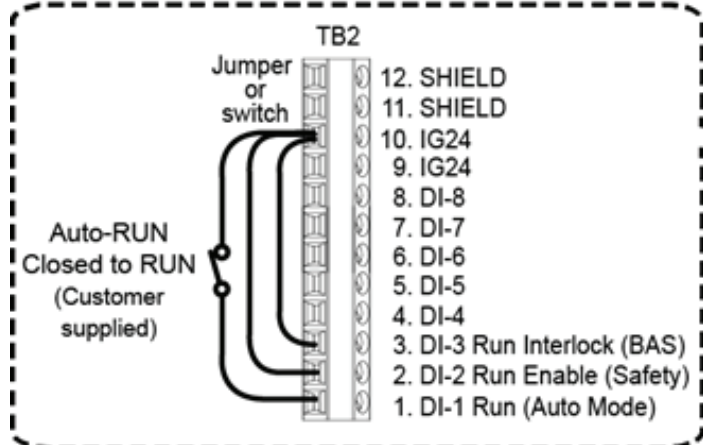
Problem/Symptom	Solution
<p>Drive Will Not Start</p> <p>AUTO LED is OFF and DRV-OFF on HOA Keypad</p> <p>Bypass is not in AUTO</p>  <p>DRV-OFF is displayed and AUTO key LED is OFF.</p>	<p>Press  to put the bypass in AUTO Mode.</p> <p>Set Z1-06 to 1 (Power-Up Mode is AUTO-DRIVE) and cycle power to put the bypass in AUTO Mode at power-up.</p>
Problem/Symptom	Solution
<p>Drive Will Not Start</p> <p>AUTO LED Is Blinking Green and WAIT FOR RUN is displayed on the HOA Keypad</p>  <p>WAIT FOR RUN is displayed and AUTO key LED flashes if AUTO Mode is active but AUTO Run Command is not closed TB2-1 to 10.</p>	<p>Verify Bypass Control Board circuit TB2-1 to 10 is closed.</p>  <p>Auto-RUN Closed to RUN (Customer supplied)</p> <p>TB2</p> <ul style="list-style-type: none"> 12. SHIELD 11. SHIELD 10. IG24 9. IG24 8. DI-8 7. DI-7 6. DI-6 5. DI-5 4. DI-4 3. DI-3 Run Interlock (BAS) 2. DI-2 Run Enable (Safety) 1. DI-1 Run (Auto Mode)

STEP 13 **BACnet Communications (OPTIONAL)**

This section describes basic steps required to configure and monitor the drive for BACnet communications.

The Z1000U Bypass can be monitored and controlled by a controller on a Building Automation and Control network (BACnet) using RS-485 connection and MS/TP (Master-Slave/Token-Passing) protocol. The Bypass conforms to the BACnet application specific controller (B-ASC) device profile. BACnet MS/TP connection is made to the bypass control board terminal TB3. Parameters and monitors for both the Z1000U drive and the bypass controller are made accessible by this single BACnet connection.

13.1 Connect BACnet wiring to Z1000U Bypass.

With the power shut off, connect the master controller communications cable to the Z1000U Bypass Control Board, terminal TB3.

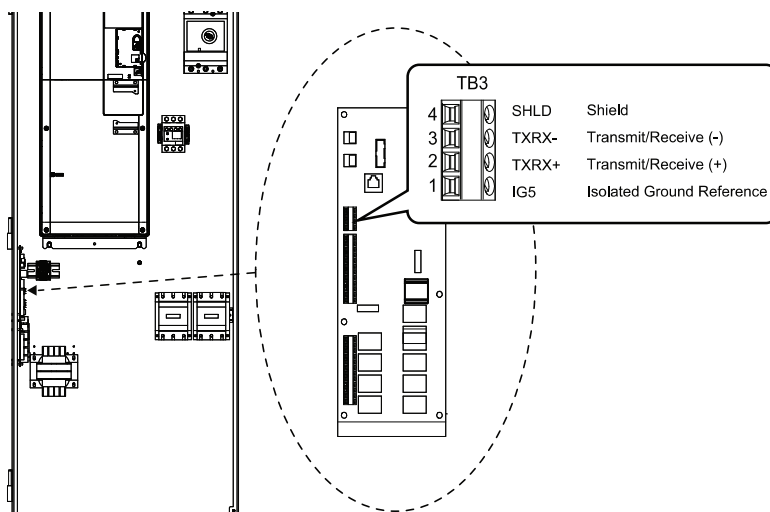

13.2 Connect RS-485 network wiring.

Connect the shield drain wire to earth ground at the controller side only to avoid ground loops. The shield drain wire should be insulated from contacting other components or ground at all other network locations. Alternate shield grounding topologies may be used if common mode noise issues are suspected.

NOTE: The isolated ground (IG5) connection is optional but strongly recommended to avoid noise issues. Yaskawa recommends using Belden cable 3106A or equivalent for BACnet operation.

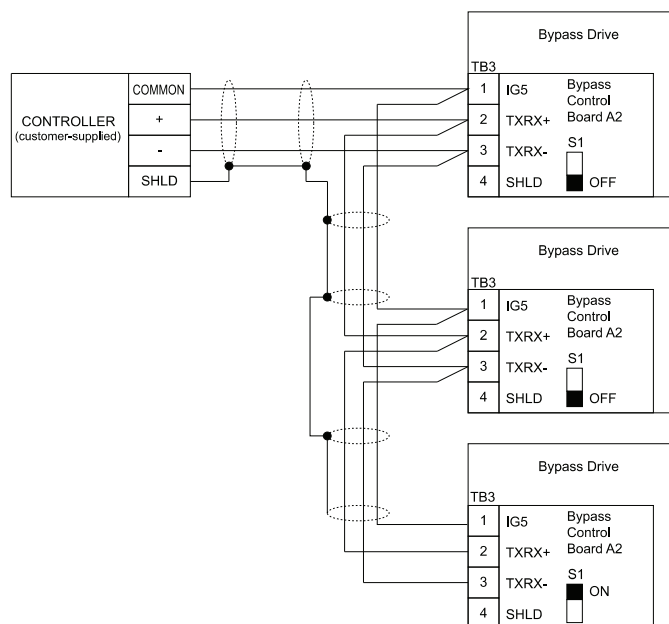

**STEP
13**

□ BACnet Communications (OPTIONAL) (continued)

13.3 Terminate the end nodes of the BACnet network.

Terminate the two ends of the BACnet network line with a 120 ohm resistor between the TXRX+ and TXRX signals. The Z1000U Bypass has a built in termination resistor that is enabled or disabled using DIP switch S1 located on the bypass control board.

Enable the termination resistor by setting DIP switch S1 to the ON position if the bypass is located at the end of a network line.

Disable the termination resistor on all bypass slaves that are not located at the network line end.

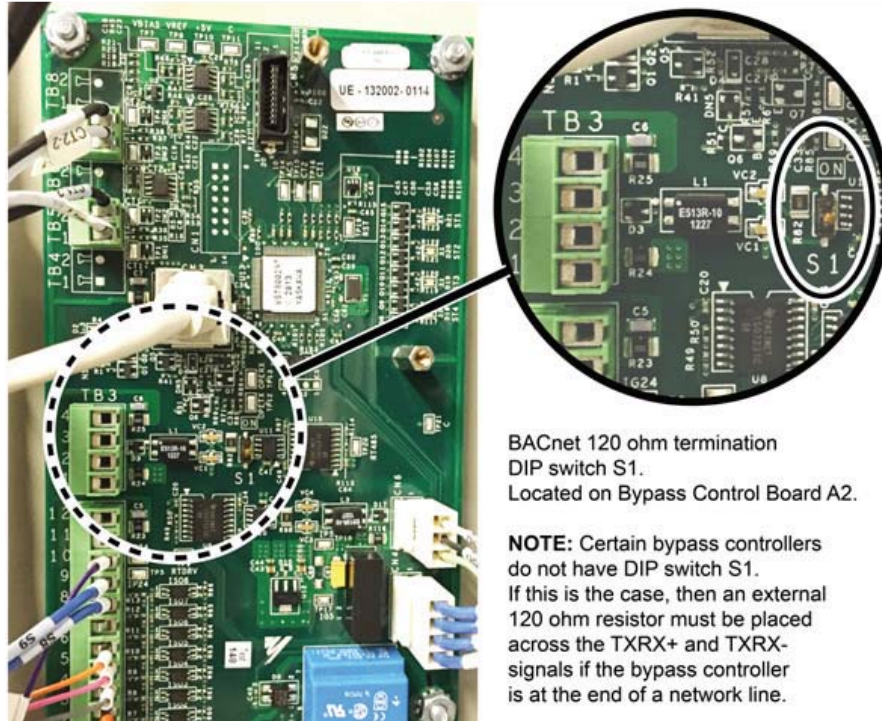

BACnet 120 ohm termination
DIP switch S1.
Located on Bypass Control Board A2.

NOTE: Certain bypass controllers do not have DIP switch S1. If this is the case, then an external 120 ohm resistor must be placed across the TXRX+ and TXRX-signals if the bypass controller is at the end of a network line.

13.4 Set these Parameters

- Z3-01 = 3 (Serial Communications Protocol Select = BACNet)
- Z3-02 = Unique MAC address number (No two devices on the MS/TP BACnet network can be the same.)
- Z3-03 = Baud Rate (Set all devices on the BACnet network for the same baud rate)
- Z3-04 = 0 (No Parity)
- Z3-05 = 0 or 1 (Ignore or Alarm Only. Set time to alarm using parameter Z3-06.)
- Z3-08 and Z3-09 = BACnet Object ID number (in hexadecimal) (No two devices on the entire BACnet network (MS/TP and BACnet/IP) may have the same BACnet Object ID number.)

13.5 Cycle Incoming Power

Z1000U Bypass main input power must be de-energized and remain off until all HOA keypad indications are extinguished. This process stores and saves the Z3 parameter settings.

Commonly Used Objects for Monitoring a Bypass

Object ID	Description (Object Name)
AV10	Drive Output Frequency (Output Frequency)
AV12	Drive Output Current (Output Current)
AV13	Drive Output Power (Output Power)
AI10	Output Current During Bypass (Motor Current UB-01)
BV89	Run Status, drive and bypass (BYP Run Status)
BV90	Fault Status, drive and bypass (BYP Fault Status)
BV83	In Drive Mode (BYP DRV Mode Status)
BV84	In Bypass Mode (BYP BYPASS Mode Stat)

STEP 14 □ Connection Diagram

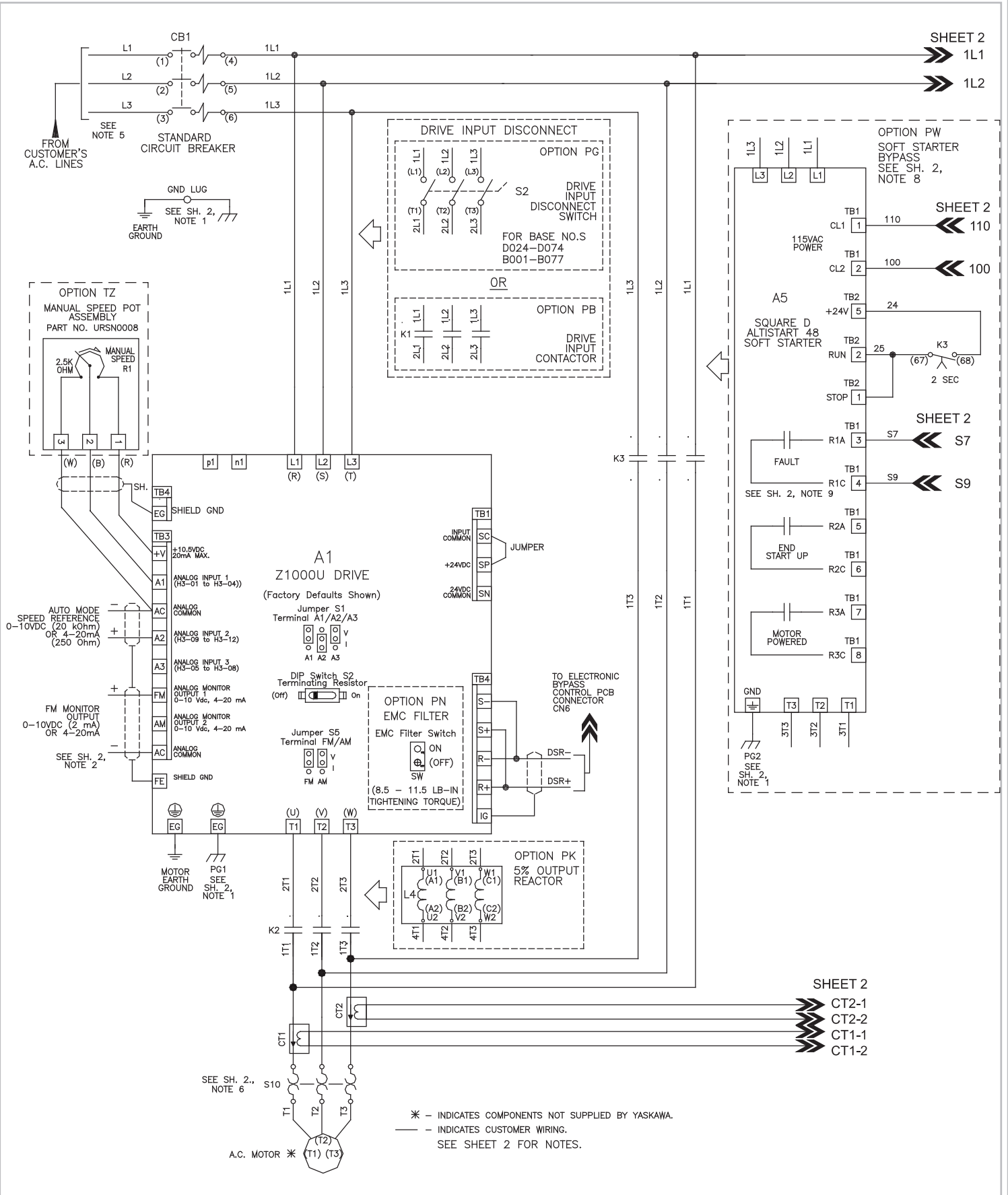

STEP 14 □ Connection Diagram (continued)

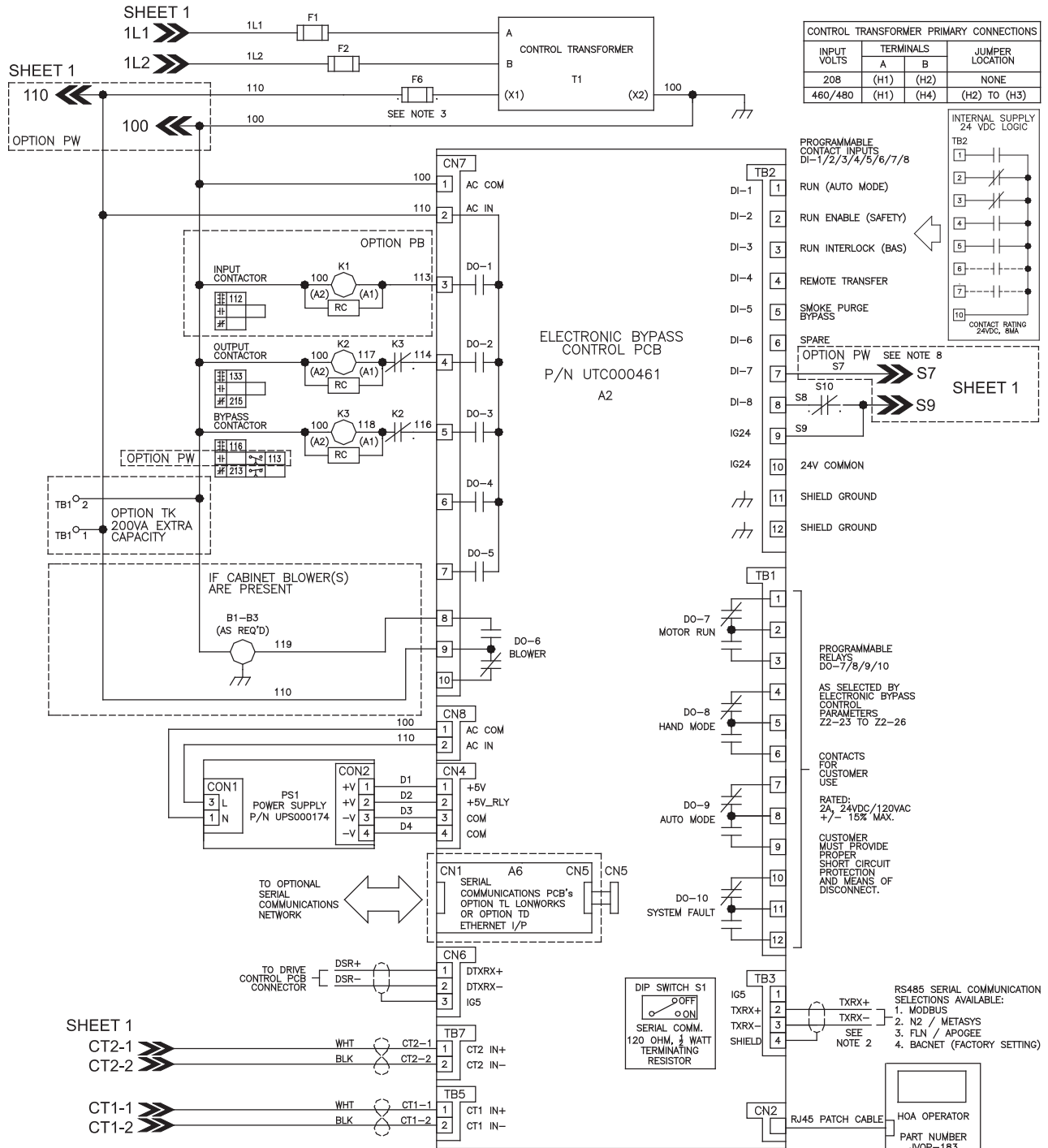

- NOTES:
1. CONNECTED TO THE CABINET. CUSTOMER TO CONNECT THE CABINET GROUND LUGS TO EARTH GROUND AND UTILITY GROUND.
 2. INSULATED TWISTED SHIELDED WIRE IS REQUIRED. SHIELD TO CONNECT TO PROPER TERMINAL AS SHOWN. CONNECT THE SHIELD ONLY AT THIS END. STUB AND ISOLATE THE OTHER END. DO NOT RUN THESE WIRES IN THE SAME CONDUIT AS THE AC POWER AND THE AC CONTROL WIRES.
 3. WITH A CONTROL TRANSFORMER, T1, POWER RATING 350VA OR GREATER, SECONDARY FUSE F6 IS ADDED.
 4. CHANGING Z1-01 TO "1" WILL PROGRAM THE DRIVE AND BYPASS PARAMETERS TO THEIR FACTORY DEFAULT SETTINGS.
 5. FOR 208VAC APPLICATIONS, SET Z1000U DRIVE PARAMETER E1-01 TO 208 AND SET Z1000U DRIVE PARAMETER E1-05 TO 208.
 6. THE MOTOR OVERLOAD RELAY IS FACTORY SET FOR MANUAL RESET. CUSTOMER TO ADJUST THE MOTOR OVERLOAD RELAY TRIP SETTING FOR THE ACTUAL AC MOTOR'S FULL LOAD AMPS.
 7. CONDUIT FITTINGS/HUBS SHALL COMPLY WITH THE "STANDARD FOR CONDUIT, TUBING, AND CABLE FITTINGS, UL 514B" OR CONDUIT FITTINGS HAVING THE SAME ENVIRONMENTAL RATING AS THE ENCLOSURE SHALL BE USED.
 8. FOR APPLICATIONS WITH SOFT STARTER BYPASS OPTION PW, SET Z1000U DRIVE PARAMETERS Z2-07 TO 36, Z2-15 TO 1, AND Z1-42 TO 1. THIS WILL CAUSE THE Z1000U DRIVE KEYPAD TO EXHIBIT AN "EFB" FAULT WHEN THE SOFT STARTER FAILS, AND THE AC MOTOR COASTS TO A STOP. CUSTOMER TO ALSO SET SOFT STARTER PARAMETER IN (IN THE SETTINGS MENU) FOR THE ACTUAL AC MOTOR'S FULL LOAD AMPS.
 9. R1 IS A FAIL-SAFE CONTACT. THE SCHEMATIC SHOWS IT IN ITS DE-ENERGIZED STATE. CONTACT STATUS IS:
 - A. OPEN WITH NO POWER APPLIED TO THE LINE SIDE OF THE SOFT STARTER.

Z1000U HVAC MATRIX Bypass

Low Harmonic Drive Bypass for HVAC Applications

Quick Start Procedure

YASKAWA AMERICA, INC.

2121, Norman Drive South, Waukegan, IL 60085, U.S.A.
Phone: 1-800-YASKAWA (927-5292) or 1-847-887-7000 Fax: 1-847-887-7310
<http://www.yaskawa.com>

DRIVE CENTER (INVERTER PLANT)

2-13-1, Nishimiyaichi, Yukuhashi, Fukuoka, 824-8511, Japan
Phone: 81-930-25-3844 Fax: 81-930-25-4369
<http://www.yaskawa.co.jp>

YASKAWA ELECTRIC CORPORATION

New Pier Takeshiba South Tower, 1-16-1, Kaigan, Minatoku, Tokyo, 105-6891, Japan
Phone: 81-3-5402-4502 Fax: 81-3-5402-4580
<http://www.yaskawa.co.jp>

YASKAWA ELÉTRICO DO BRASIL LTDA.

777, Avenida Piraporinha, Diadema, São Paulo, 09950-000, Brasil
Phone: 55-11-3585-1100 Fax: 55-11-3585-1187
<http://www.yaskawa.com.br>

YASKAWA EUROPE GmbH

185, Hauptstraße, Eschborn, 65760, Germany
Phone: 49-6196-569-300 Fax: 49-6196-569-398
<http://www.yaskawa.eu.com>

YASKAWA ELECTRIC KOREA CORPORATION

9F, Kyobo Securities Bldg., 26-4, Yeouido-dong, Yeongdeungpo-gu, Seoul, 150-737, Korea
Phone: 82-2-784-7844 Fax: 82-2-784-8495
<http://www.yaskawa.co.kr>

YASKAWA ELECTRIC (SINGAPORE) PTE. LTD.

151, Lorong Chuan, #04-02A, New Tech Park, 556741, Singapore
Phone: 65-6282-3003 Fax: 65-6289-3003
<http://www.yaskawa.com.sg>

YASKAWA ELECTRIC (CHINA) CO., LTD.

22F, One Corporate Avenue, No.222, Hubin Road, Shanghai, 200021, China
Phone: 86-21-5385-2200 Fax: 86-21-5385-3299
<http://www.yaskawa.com.cn>

YASKAWA ELECTRIC (CHINA) CO., LTD. BEIJING OFFICE

Room 1011, Tower W3 Oriental Plaza, No. 1, East Chang An Ave.,
Dong Cheng District, Beijing, 100738, China
Phone: 86-10-8518-4086 Fax: 86-10-8518-4082

YASKAWA ELECTRIC TAIWAN CORPORATION

9F, 16, Nanking E. Rd., Sec. 3, Taipei, 104, Taiwan
Phone: 886-2-2502-5003 Fax: 886-2-2505-1280

YASKAWA INDIA PRIVATE LIMITED

#17/A, Electronics City, Hosur Road, Bangalore, 560 100 (Karnataka), India
Phone: 91-80-4244-1900 Fax: 91-80-4244-1901
<http://www.yaskawaindia.in>

YASKAWA

YASKAWA AMERICA, INC.

In the event that the end user of this product is to be the military and said product is to be employed in any weapons systems or the manufacture thereof, the export will fall under the relevant regulations as stipulated in the Foreign Exchange and Foreign Trade Regulations. Therefore, be sure to follow all procedures and submit all relevant documentation according to any and all rules, regulations and laws that may apply.

Specifications are subject to change without notice for ongoing product modifications and improvements.

© 2015 YASKAWA AMERICA INC. All rights reserved.



TOEPYAIZD01

MANUAL NO. TOEPYAIZ1D01A

Published in U.S.A. June 2015 15-06 