

MBH

17
15
13
11
9
7
5
3
1



ARI
PERFORMANCE
CERTIFIED

Nailor
Industries Inc.

BYPASS TERMINAL UNITS

Contents

	Page No.
Introduction and Features	
3400 • Basic Unit	F3
34RW • With Hot Water Reheat	F3
34RE • With Electric Reheat	F3
Dimensional Data	
3400 • Basic Unit	F5
• Integral Sound Attenuator	F6
34RW • With Hot Water Coil	F6
• Integral Sound Attenuator with Hot Water Coil	F6
34RE • Integral Electric Coil	F6
Accessories • AT Discharge Attenuator	F7
• FF Round Discharge Collar	F7
• MOA Multi-Outlet Attenuator	F7
Performance Data	
NC Level Application Guide	F8
Sound Power Levels	F9
Standard Control Sequences	F10
Hot Water Coil Performance Data	F13
Electric Coil Selection	F18
Balancing Procedure	F19
Suggested Specifications	F20

BYPASS TERMINAL UNITS 3400 SERIES MARK II

- "DUMP BOX"
- UNIQUE "FLOW DIVERTER" VALVE

Models:

- 3400** Cooling
- 34RW** Cooling with Hot Water Reheat
- 34RE** Cooling with Electric Reheat



Model 3400

The **3400 Series – Bypass Terminal Unit** is a single duct pressure dependent air terminal unit, designed for use with popular constant volume low and medium pressure packaged air handling systems or roof top air conditioning units at low prime cost. Units may be used with cooling and heating/cooling systems. Temperature control is achieved by supplying only enough conditioned air to the space to satisfy room thermostat demand. Excess air is diverted (bypassed) directly to the return air ceiling plenum for free or ducted return. Airflow to each occupied zone will vary on thermostat demand, from full flow to shut-off or to a mechanically set minimum air volume.

A bypass box, commonly referred to also as a "dump box" handles a constant supply of primary air through its inlet and uses a diverting damper to bypass part of the supply air into the plenum return. The damper is directly controlled by the room thermostat in the occupied space to provide the volume of air required to meet the thermal demand. The pressure requirement through the supply air path to the conditioned space is set with an inlet balancing damper. A second manual balancing damper in the bypass is field adjusted to match the resistance in the discharge duct in order to maintain minimum airflow to the space, maintain supply air from the primary system at a constant volume and ensure smooth modulation of the supply airflow volume.

Bypass terminals can be added to a single-zone constant volume system to provide zoning without the energy penalty of a conventional reheat system, providing low first cost with minimum fan controls. Although variable volume to the space in operation, total airflow of the fan remains constant, so the fan power and associated energy cost are not reduced. This method is therefore energy inefficient as compared to a VAV fan system. Its most frequent application is on small systems.

FEATURES:

- Casing – 22 ga. galvanized steel with round or flat oval inlets. Outlets are rectangular with slip and drive connections.
- Damper – New heavy gauge steel cylindrical "Flow Diverter" valve design for reliable long term operation. Eliminates any internal damper linkage. 90° rotation. CW to close.
- 1/2" (13) dia. plated steel driveshaft. An indicator mark on the end of the shaft shows damper position.
- 3/4" (19) dual density insulation. Exposed edges are coated to prevent airflow erosion. Material meets requirement of NFPA 90A and UL 181 standards.

- Inlet balancing damper.
- Easily adjustable bypass port balancing dampers.
- Sizes range from 6" (152) to 16" (406) with capacities from 100 to 2750 cfm. Tested in accordance with ANSI/ASHRAE Standard 130-1996 and ARI 880-98, in an independent test laboratory.
- Compact low profile design is ideally suited for installation in tight spaces.
- Minimum air volume stop on electric actuator. It cannot be factory set and must be field adjusted as required for the application.

Controls:

- Pressure dependent pneumatic or analog electronic control. Factory

supplied and mounted.

- Variety of control options available, based on applications.
- Electronic thermostat and actuator provide accurate modulating control.

Options:

- Hot water and electric reheat coil sections.
- Multi-outlet plenum.
- Round/Oval discharge collar.



ARI Standard 880

A Participating Corporation in the ARI 880 Certification program.



F

BYPASS TERMINAL UNITS

Unique "Flow Diverter" Valve

Nailor's 3400 Series Mark II bypass terminal units utilize a unique cylindrical flow diverter valve for superior control and performance. A common problem with standard pivoted single blade damper designs is objectionable noise and loss of modulation due to pulsating and/or a snap-closing action of the valve. This is caused by a poor valve design, which struggles to modulate turbulent airflow and requires excessive torque.

The Nailor flow diverter valve eliminates these problems. The rugged cylindrical damper design smoothly modulates between supply and bypass conditions and when installed under airflow is essentially self-balancing, requiring only a negligible torque requirement. The result is superior reliable long-term performance and quiet operation.

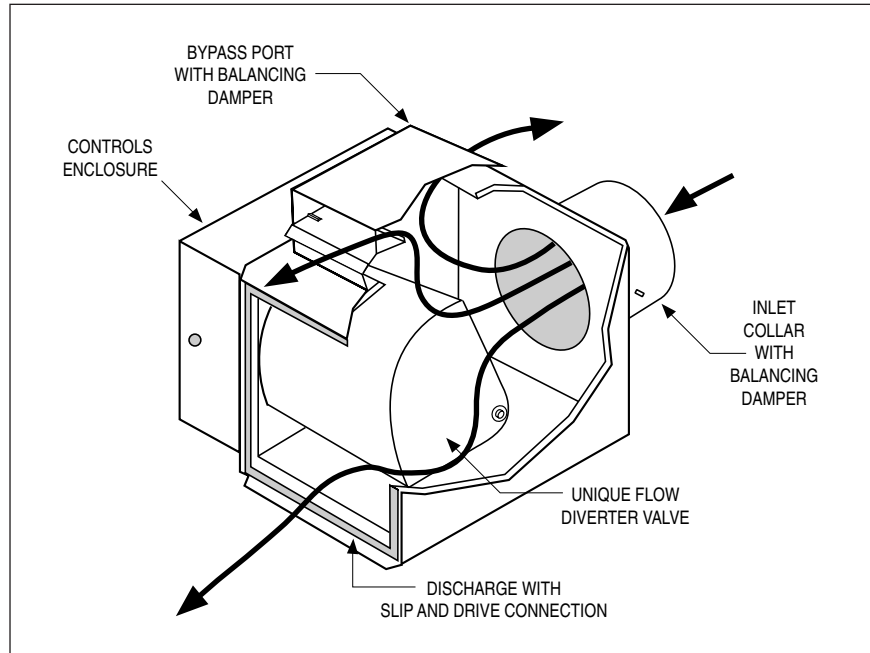

BYPASS TERMINAL UNITS

Electronic Modulating Controls

Nailor offers a series of state of the art analog electronic control packages which provide true modulating control and superior performance over conventional electric controls. These older packages essentially provide on/off control of the bypass terminal. Commonly, the damper is driven to the full supply or full bypass position before a change in space temperature is sensed by the room thermostat. Low speed actuators are often used to slow the damper response, but result in sluggish control and large swings in occupied space temperature which waste energy and provide poor comfort.

Nailor's electronic packages feature advanced microcomputer electronics and proportional plus integral (P + I) control algorithms to provide precise temperature control. The thermostat provides a true multi-position modulating output to a conventional 24 VAC tri-state floating actuator. The thermostat output cycles the actuator with shorter or longer "on times" proportional to the temperature offset, preventing temperature overshoot. The thermostat also tracks how long the room temperature has varied from set point and adjusts the output accordingly. This eliminates wasted energy caused by typical on/off cycling with conventional SPDT thermostats, resulting in significant energy savings and superior comfort. Control deadband accuracy is +/- 0.4°F (+/- 0.2°C) around set point. When a reheat stage is required, the electronic thermostat provides a time proportioning on/off output signal based on a 15 minute duty cycle that proportionately modulates the reheat coil, adjusting the amount of "on time" in accordance with room temperature offset. This feature provides performance similar to an SCR controller, but at a fraction of the cost.

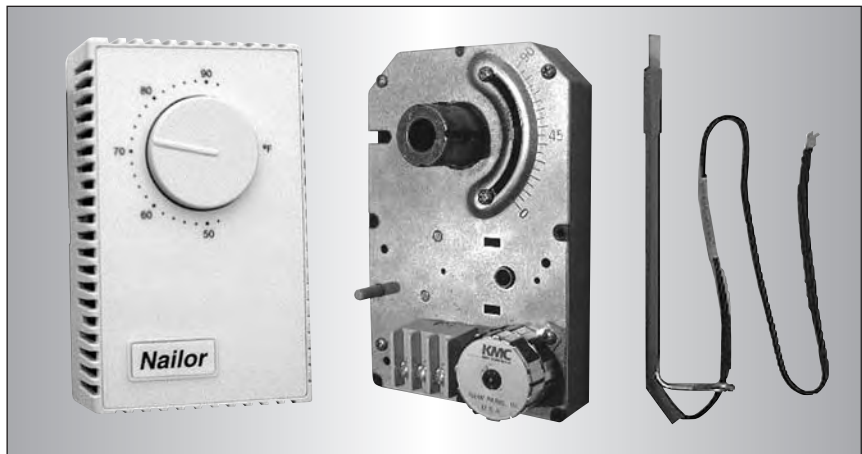

Options:

- Thermostat Scale Plate °F or °C.
- 24 VAC Control transformer.
- Toggle disconnect switch.

Dimensions

Model Series 3400 • Basic Unit with Controls

Pneumatic Controls

- Direct drive rotary pneumatic actuator. MCP-3631 Series. Minimum damper position must be field set.

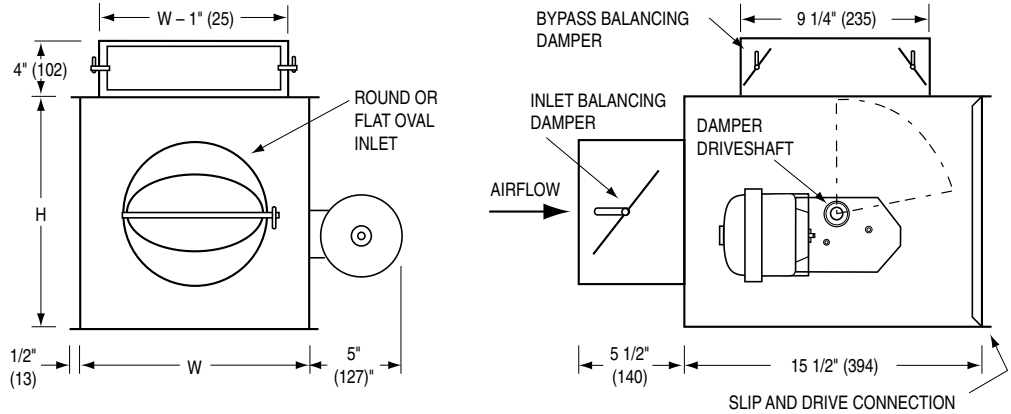

Analog Electronic Controls

- A full NEMA 1 controls enclosure is provided for factory mounted controls. Optional for field mounted controls.

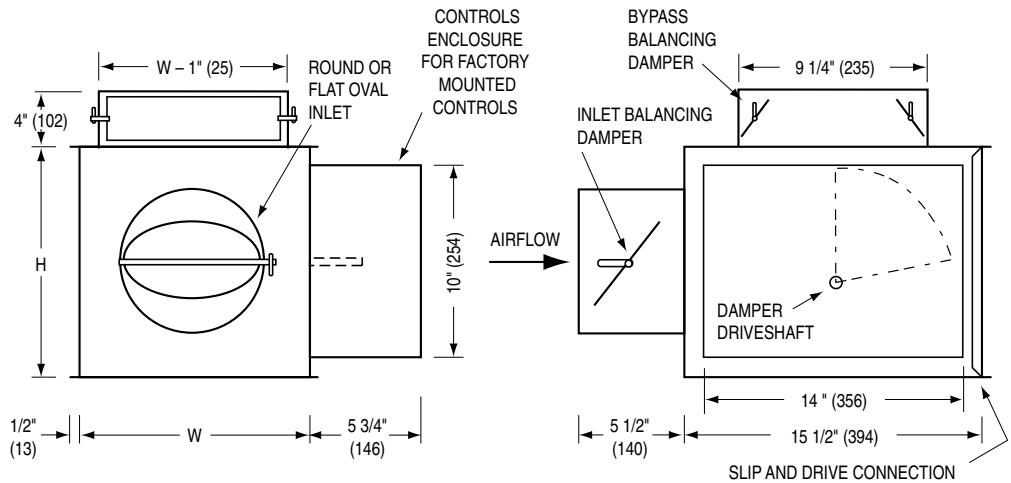

Dimensional Data

Imperial Units (inches)				
Unit Size	cfm Range	W	H	Inlet Size
6	0 – 400	10	12 1/2	5 7/8 Round
8	0 – 700	12	12 1/2	7 7/8 Round
10	0 – 1100	14	12 1/2	9 7/8 Round
12	0 – 1600	18	12 1/2	12 15/16 x 9 13/16 Oval
14	0 – 2100	24	12 1/2	16 1/16 x 9 13/16 Oval
16	0 – 2800	28	12 1/2	19 3/16 x 9 13/16 Oval

Metric Units (mm)				
Unit Size	l/s Range	W	H	Inlet Size
6	0 – 189	254	318	149 Round
8	0 – 330	305	318	200 Round
10	0 – 519	356	318	251 Round
12	0 – 755	457	318	329 x 249 Oval
14	0 – 991	610	318	408 x 249 Oval
16	0 – 1322	711	318	487 x 249 Oval

Dimensions

Model Series 3400 • Bypass Terminal Unit Accessories

Integral Sound Attenuator

- Single continuous length terminal construction minimizes casing leakage.
- Continuous internal insulation reduces insulation seams and minimizes airflow disturbance.

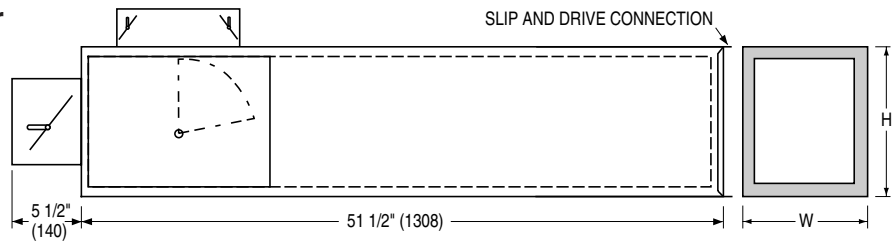

Hot Water Reheat Coils

- One and two row standard. Three and four row available.
- Hot water coils have copper tubes and aluminum ripple fins. Coils have 1/2" (13) or 7/8" (22) O.D. sweat connections. Right or left hand connection is determined by looking through the terminal inlet in the direction of airflow.
- Galvanized steel casing with slip and drive discharge duct connection.
- Optional low leakage gasketed access door is recommended for coil access and cleaning. Performance data on page F13.

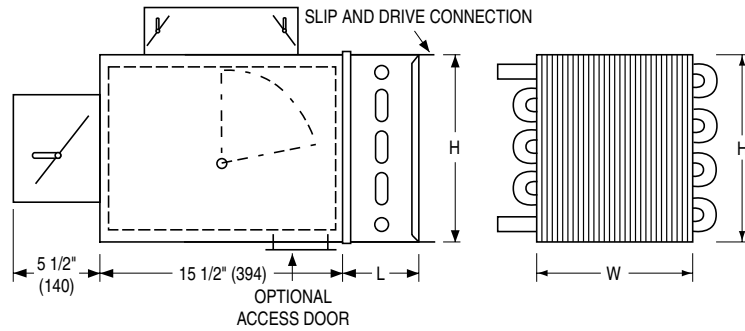

Integral Attenuator plus Hot Water Coil

- All the benefits of both the Integral Sound Attenuator and the Hot Water Coils shown above in one.
- Performance data on page F13.

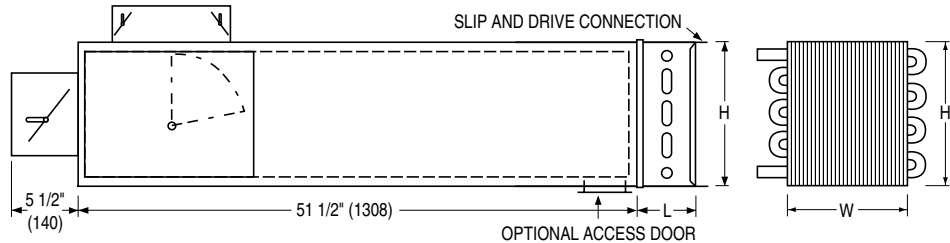

Integral Electric Reheat

- Electric coil is factory mounted in an integral extended plenum section.
- Full details and selection guide on page F18.

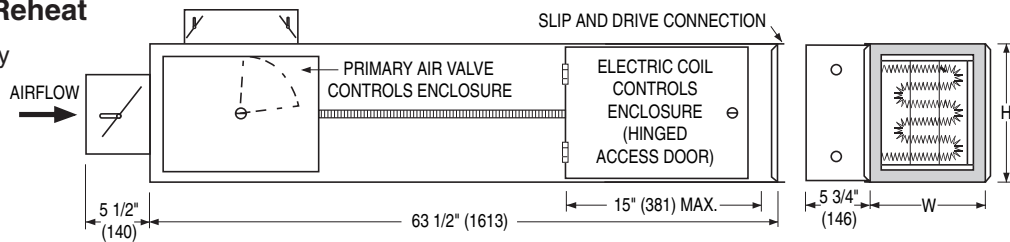

Dimensional Data

Imperial Units (inches)				
		Hot Water Coil		
Unit Size	W	H	L (1 & 2 row)	L (3 & 4 row)
6	10	12 ½	5	7 ½
8	12	12 ½	5	7 ½
10	14	12 ½	5	7 ½
12	18	12 ½	5	7 ½
14	24	12 ½	5	7 ½
16	28	12 ½	5	7 ½

Metric Units (mm)				
		Hot Water Coil		
Unit Size	W	H	L (1 & 2 row)	L (3 & 4 row)
6	254	318	127	191
8	305	318	127	191
10	356	318	127	191
12	457	318	127	191
14	610	318	127	191
16	711	318	127	191

Dimensions

Model Series 3400 • Bypass Terminal Unit Accessories

AT Discharge Sound Attenuator

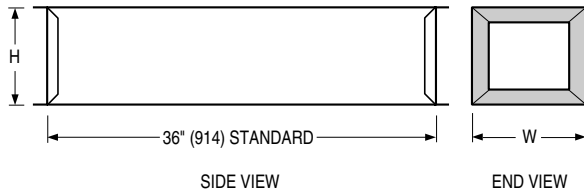

- Shipped loose for field attachment.
- Slip and drive connection.
- 3/4" (19), dual density internal insulation standard. Treated to prevent erosion.

FF Round Discharge Collar

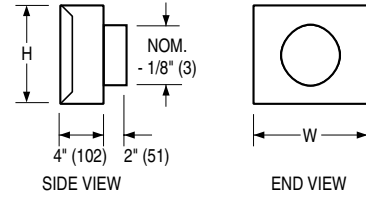

MOA Multi-Outlet Attenuator (3 ft. (914))

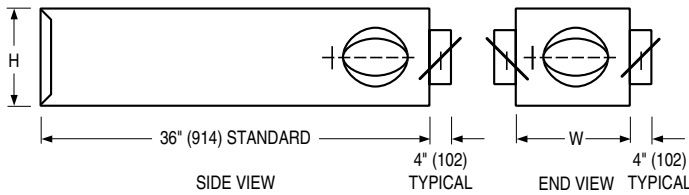

- Only one outlet size to be specified per M.O.A. No mixing of outlet sizes on the same unit. Number and size of outlets on M.O.A. not to exceed the limits listed in table, both maximum quantity of outlets and maximum size of outlet.
- All round outlets c/w manual dampers with hand locking quadrant.
- 3/4" (19) dual density insulation.
- Denotes inlet airflow direction. →
- For special outlet sizes and arrangements, consult your Nailor representative.

Unit Size	M.O.A. Outlets
6 (152)	3 @ 6" (152)
8 (203)	5 @ 8" (203) 5 @ 6" (152)
10 (254)	3 @ 10" (254) 5 @ 8" (203)
12 (305)	5 @ 8" (203) 5 @ 10" (254)
14, 16 (356, 406)	5 @ 10" (254)

Standard Outlet Arrangements

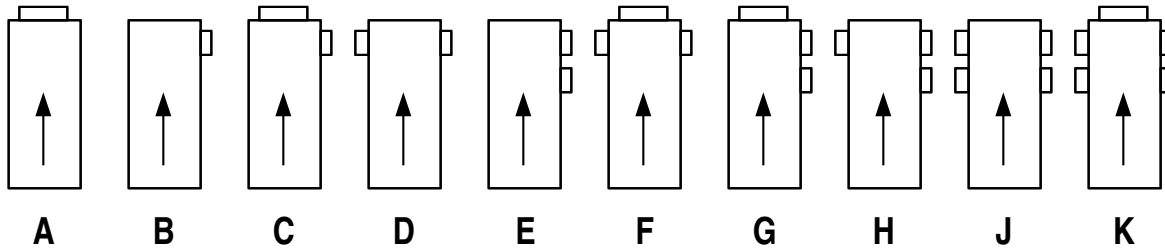

Dimensional Data

Unit Size	Imperial Units			Metric Units		
	W	H	FF Outlet Size	W	H	FF Outlet Size
6	10	12 ½	6	254	318	152
8	12	12 ½	8	305	318	203
10	14	12 ½	10	356	318	254
12	18	12 ½	12	457	318	305
14	24	12 ½	14	610	318	356
16	28	12 ½	16	711	318	406

Performance Data • NC Level Application Guide Model Series 3400

Inlet Size	Airflow cfm /s		Min. Discharge ΔPs "w.g. Pa		Min. Bypass ΔPs "w.g. Pa		NC Levels		
							Discharge	Radiated	
								Bypass Closed	Bypass Open
6	400	189	0.01	2	0.14	35	-	-	25
	300	142	0.01	2	0.08	20	-	-	-
	200	94	0.01	2	0.04	10	-	-	-
	100	47	0.01	2	0.01	2	-	-	-
8	700	330	0.01	2	0.21	52	-	-	30
	500	236	0.01	2	0.11	27	-	-	20
	350	165	0.01	2	0.05	12	-	-	-
	200	94	0.01	2	0.02	5	-	-	-
10	1100	519	0.01	2	0.43	107	-	20	37
	800	378	0.01	2	0.23	57	-	-	25
	500	236	0.01	2	0.09	22	-	-	-
	250	118	0.01	2	0.02	5	-	-	-
12	1600	755	0.01	2	0.50	124	-	20	40
	1200	566	0.01	2	0.28	70	-	-	33
	800	378	0.01	2	0.13	32	-	-	22
	400	189	0.01	2	0.03	7	-	-	-
14	2100	991	0.05	12	0.50	124	-	31	43
	1600	755	0.03	7	0.29	72	-	24	35
	1050	495	0.01	2	0.12	30	-	-	23
	550	260	0.01	2	0.03	7	-	-	-
16	2750	1298	0.06	15	0.50	124	21	34	47
	2050	967	0.03	7	0.28	70	-	24	37
	1375	649	0.01	2	0.13	32	-	-	27
	700	330	0.01	2	0.03	7	-	-	-

Performance Notes:

1. NC levels are calculated from the published raw data and based on procedures outlined in Appendix E, ARI 885-98.

2. Discharge sound attenuation deductions are based on environmental effect, duct lining, branch power division, insulated flex duct, end reflection and space effect and are as follows:

Discharge attenuation	Octave Band					
	2	3	4	5	6	7
< 300 cfm	24	28	39	53	58	40
300 – 700 cfm	27	29	40	51	53	39
> 700 cfm	29	30	41	51	52	39

3. Radiated sound attenuation deductions are based on a mineral tile ceiling and environmental effect and are as follows:

Radiated attenuation	Octave Band					
	2	3	4	5	6	7
Total dB reduction	18	19	20	26	31	36

4. Minimum discharge ΔPs is the static pressure loss through the unit with 100% airflow through discharge outlet.

5. Minimum bypass ΔPs is the static pressure loss through the unit with 100% airflow through the bypass outlet.

6. Dash (–) in space denotes an NC level of less than 20.

7. For a complete explanation and details on NC calculations, refer to page B9 and the engineering section of this catalog.



Performance Data • Sound Power Levels

Model Series 3400

Inlet Size	Airflow cfm /s		Min. Discharge ΔPs "w.g. Pa	Min. Bypass ΔPs "w.g. Pa	Sound Power Octave Bands																			
					Discharge							Radiated												
												Bypass Closed				Bypass Open								
					2	3	4	5	6	7	2	3	4	5	6	7	2	3	4	5	6	7		
6	400	189	0.01	2	0.14	35	45	44	41	33	29	26	42	37	33	24	20	20	54	55	52	52	51	37
	300	142	0.01	2	0.08	20	43	38	34	25	-	-	-	34	25	-	-	-	47	48	45	47	37	26
	200	94	0.01	2	0.04	10	-	31	24	-	-	-	-	-	-	-	-	-	-	38	34	32	-	-
	100	47	0.01	2	0.01	2	-	-	-	-	-	-	-	-	-	-	-	-	-	34	29	-	-	-
8	700	330	0.01	2	0.21	52	52	51	47	39	36	33	47	41	34	28	26	20	60	59	55	53	48	41
	500	236	0.01	2	0.11	27	45	43	38	29	24	-	43	34	27	-	-	-	52	50	46	43	3	28
	350	165	0.01	2	0.05	12	-	34	28	-	-	-	-	32	-	-	-	-	47	40	37	32	25	-
	200	94	0.01	2	0.02	5	-	-	-	-	-	-	-	-	-	-	-	-	43	30	-	-	-	-
10	1100	519	0.01	2	0.43	107	50	50	46	43	37	34	52	49	46	37	32	23	65	64	62	60	56	52
	800	378	0.01	2	0.23	57	47	47	36	30	28	22	49	43	39	28	26	-	56	55	52	50	46	41
	500	236	0.01	2	0.09	22	44	40	34	28	-	-	43	35	29	-	-	-	47	45	43	41	34	-
	250	118	0.01	2	0.02	5	40	30	-	-	-	-	-	-	-	-	-	-	42	28	-	-	-	-
12	1600	755	0.01	2	0.50	124	49	47	45	43	44	40	48	51	47	37	35	29	69	69	66	63	60	56
	1200	566	0.01	2	0.28	70	44	40	38	36	36	29	43	41	38	29	25	-	61	60	58	56	52	46
	800	378	0.01	2	0.13	32	40	31	25	-	-	-	40	33	29	-	-	-	50	49	49	46	39	31
	400	189	0.01	2	0.03	7	-	-	26	-	-	-	-	-	25	-	-	-	44	40	41	35	28	-
14	2100	991	0.05	12	0.50	124	60	57	54	48	45	36	54	58	56	49	49	41	69	69	67	65	61	57
	1600	755	0.03	7	0.29	72	54	49	44	39	34	24	48	50	49	42	40	29	62	62	60	57	53	48
	1050	495	0.01	2	0.12	30	47	37	31	24	-	-	44	40	38	29	-	-	51	50	50	45	40	31
	550	260	0.01	2	0.03	7	-	31	-	-	-	-	-	31	26	-	-	-	-	37	36	29	-	-
16	2750	1298	0.06	15	0.50	124	66	64	61	56	52	46	64	63	59	49	46	37	73	73	71	69	65	61
	2050	967	0.03	7	0.28	70	58	56	51	46	42	34	57	54	50	41	36	25	65	65	63	61	56	50
	1375	649	0.01	2	0.13	32	50	45	39	33	27	-	45	41	38	27	-	-	54	53	53	50	44	34
	700	330	0.01	2	0.03	7	47	31	-	-	-	-	-	-	-	-	-	-	40	35	33	25	-	-

ARI Certification Rating Points

Inlet Size	Airflow cfm /s		Min. Inlet ΔPs "w.g. Pa	Sound Power Octave Bands													
				Discharge							Radiated						
				2	3	4	5	6	7	2	3	4	5	6	7		
6	400	189	0.01	2	45	44	41	33	29	26	42	37	33	24	20	20	
8	700	330	0.01	2	52	51	47	39	36	33	47	41	34	28	26	20	
10	1100	519	0.01	2	50	50	46	43	37	34	52	49	46	37	32	23	
12	1600	755	0.01	2	49	47	45	43	44	40	48	51	47	37	35	29	
14	2100	991	0.05	12	60	57	54	48	45	36	54	58	56	49	49	41	
16	2750	1298	0.06	15	66	64	61	56	52	46	64	63	59	49	46	37	



Performance Notes:

1. Discharge sound power is the noise emitted from the unit discharge into the downstream duct.
2. Radiated sound power is the breakout noise transmitted through the unit casing walls.
3. Sound power levels are in decibels, dB re 10-12 watts.

4. All sound data listed by octave bands is raw data without any corrections for room absorption or duct attenuation. Dash (-) in space indicates sound power level is less than 20 or equal to background.
5. Minimum discharge ΔPs is the static pressure loss through the unit with 100% airflow through discharge outlet.

6. Minimum bypass ΔPs is the static pressure loss through the unit with 100% airflow through the bypass outlet.
7. Data derived from tests conducted in accordance with ANSI/ASHRAE Std. 130-1996 and ARI Standard 880-98.

Standard Control Sequences Pneumatic • Pressure Dependent

A variety of popular sequences are illustrated to suit most applications. For non-standard or other specific applications, contact your Nailor representative.

Control Sequence P1

Cooling (with Optional Reheat) • Reverse Acting/Normally Open

- When main control air is off, damper is fully open and the bypass is closed.
- When main control air is on, cooling airflow modulates according to thermostat output.
- On a rise in room temperature, the thermostat line pressure to the actuator decreases. The actuator moves the damper to the open position, increasing the cooling airflow to the room, closing the bypass air at the same time.
- If the room thermostat is satisfied before the damper is fully open, the damper remains in a modulated position until further demand.
- On a fall in room temperature, the thermostat line pressure increases, moving the actuator to close the damper and decreases the cooling airflow to the room. At the same time, supply air is diverted through the bypass port into the plenum.
- A mechanical minimum stop requires field setting.
- An optional hot water coil valve or electric heater may be sequenced for reheat applications (8 – 13 psi). Hot water valve is supplied by others. P.E. switch is included in electric heater.

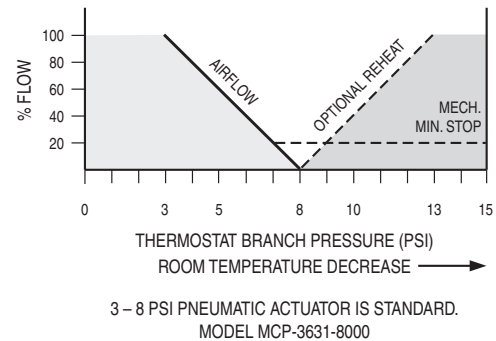

Control Sequence Package P1A

Cooling (with Optional Reheat) • Direct Acting/Normally Closed

- When main control air is off, damper is fully closed and the bypass is open.
- When main control air is on, cooling airflow modulates according to thermostat output.
- On a rise in room temperature, the thermostat line pressure to the actuator increases. The actuator moves the damper to the open position, increasing the cooling airflow to the room, closing the bypass air at the same time.
- If the room thermostat is satisfied before the damper is fully open, the damper remains in a modulated position until further demand.
- On a fall in room temperature, the thermostat line pressure decreases, moving the actuator to close the damper and decreases the cooling airflow to the room. At the same time, supply air is diverted through the bypass port into the plenum.
- A mechanical minimum stop requires field setting.
- An optional hot water coil valve or electric heater may be sequenced for reheat applications (3 – 8 psi). Hot water valve is supplied by others. P.E. switch is included in electric heater.

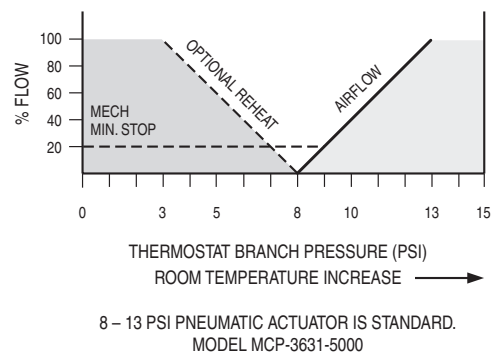

Standard Control Sequences Analog Electronic • Pressure Dependent

Control Sequence E2

Cooling Only

Central system supplies cool air. On a rise in room temperature above set point, the bypass damper will slowly modulate open, increasing the flow of air to the room, closing the bypass at the same time. On a fall in room temperature below set point, the bypass damper will modulate closed, reducing the flow of cool air into the room and opening the bypass at the same time. A mechanical air volume minimum stop is provided (field set).

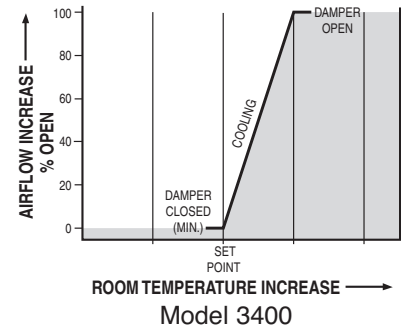

Control Sequence E3

Automatic Heating/Cooling Changeover

This arrangement is for systems supplying cool air in summer and hot air in winter. A duct temperature sensor senses inlet temperature and automatically reverses control action when supply air is above 78°F (26°C). A mechanical air volume minimum stop is provided (field set).

Cooling Mode:

Supply air system in cooling mode (below 75°F (24°C)). On a rise in room temperature above set point, the bypass damper will modulate open, increasing the flow of cool air to the room, closing the bypass at the same time. On a fall in room temperature below set point, the bypass damper will modulate closed, reducing the flow of cool air into the room and opening the bypass at the same time.

Heating Mode:

Supply air system in heating mode (above 78°F (26°C)). On a rise in room temperature above set point, the bypass damper will modulate closed, reducing the flow of warm air into the room to maintain set point and opening the bypass. On a fall in room temperature below set point, the bypass damper will modulate open, increasing the flow of warm air into the room to maintain the set point and closing the bypass at the same time.

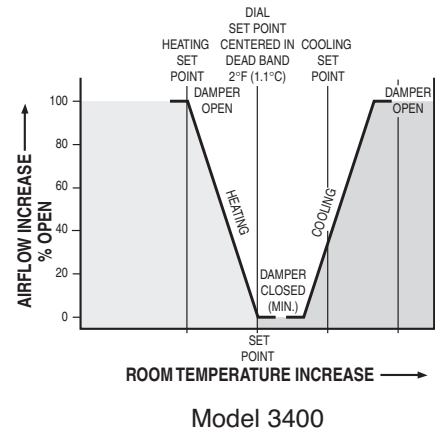

Control Sequence E4

Cooling with Auxiliary Heat (Perimeter Heating or Hot Water Reheat)

Central system supplies cool air. On a rise in room temperature above set point, the bypass damper will slowly modulate open, increasing the flow of air to the room, closing the bypass at the same time. On a fall in room temperature below set point, the bypass damper will modulate closed, reducing the flow of cool air into the room and opening the bypass at the same time.

If room temperature continues to fall, the thermostat will energize the control relay/valve of the perimeter heating or hot water valve for reheat. A mechanical air volume minimum stop is provided (field set).

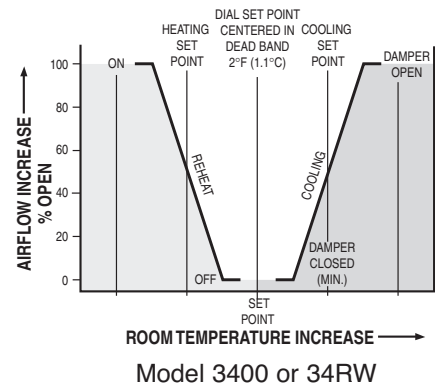

BYPASS TERMINAL UNITS

Standard Control Sequences

Analog Electronic • Pressure Dependent

Control Sequence E4

Cooling with One Stage Electric Heat

Central system supplies cool air. On a rise in room temperature above set point, the bypass damper will slowly modulate open, increasing the flow of air to the room, closing the bypass at the same time. On a fall in room temperature below set point, the bypass damper will modulate closed, reducing the flow of cool air into the room and opening the bypass at the same time.

If room temperature continues to fall, the thermostat will energize the control relay of the electric reheat coil.

Note: When an electric duct reheat coil is used, the adjustable mechanical end stop on the actuator must be field set to ensure sufficient airflow over the heating coil [70 cfm (33 l/s) per kW minimum].

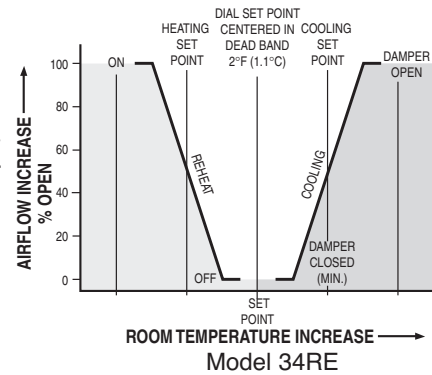

Control Sequence E5

Automatic Heating/Cooling Changeover with Auxiliary Heat (Perimeter Heating or Hot Water Heat)

This arrangement is for systems supplying cool air in summer and hot air in winter. A duct temperature sensor senses inlet temperature and automatically reverses control action when supply air is above 78°F (26°C). A mechanical air volume minimum stop is provided (field set).

Cooling Mode:

Supply air system in cooling mode (below 75°F (24°C)). On a rise in room temperature above set point, the bypass damper will modulate open, increasing the flow of cool air to the room, closing the bypass at the same time. On a fall in room temperature below set point, the bypass damper will modulate closed, reducing the flow of cool air into the room and opening the bypass at the same time. If room temperature continues to fall, the thermostat will energize the control relay/valve of the perimeter heating or hot water reheat valve for reheat.

Heating Mode:

Supply air system in heating mode (above 78°F (26°C)). On a rise in room temperature above set point, the bypass damper will modulate closed, reducing the flow of warm air into the room to maintain set point and opening the bypass. On a fall in room temperature below set point, the bypass damper will modulate open, increasing the flow of warm air into the room to maintain the set point and closing the bypass at the same time. If room temperature continues to fall, the thermostat will energize control relay/valve of the perimeter heating or the hot water valve for supplementary heat.

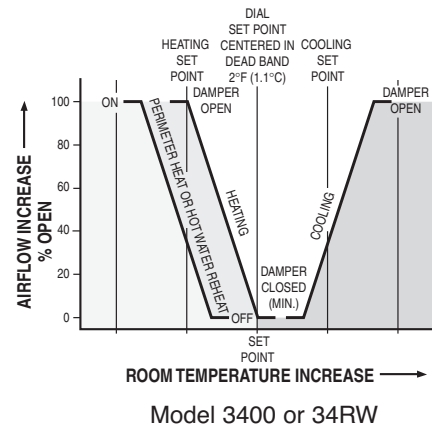

Control Sequence E5

Automatic Heating/Cooling Changeover with One Stage Electric Heat

This arrangement is for systems supplying cool air in summer and hot air in winter. A duct temperature sensor senses inlet temperature and automatically reverses control action when supply air is above 78°F (26°C).

Cooling Mode:

Supply air system in cooling mode (below 75°F (24°C)). On a rise in room temperature above set point, the bypass damper will modulate open, increasing the flow of cool air to the room, closing the bypass at the same time. On a fall in room temperature below set point, the bypass damper will modulate closed, reducing the flow of cool air into the room and opening the bypass at the same time. If room temperature continues to fall, the electric heat is energized.

Heating Mode:

Supply air system in heating mode (above 78°F (26°C)). On a rise in room temperature above set point, the bypass damper will modulate closed, decreasing the flow of cool air to the room and opening the bypass at the same time. On a fall in room temperature below set point, the bypass damper will modulate open, increasing the flow of warm air into the room and closing the bypass at the same time. If room temperature continues to fall, the electric heat is energized.

Note: The mechanical minimum stop must be field set to ensure sufficient airflow over the heating coil [70 cfm (33 l/s) per kW minimum].

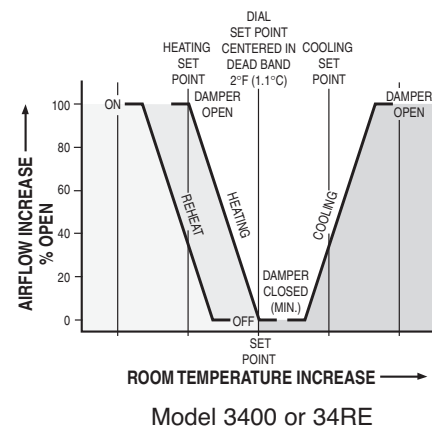

Performance Data

Hot Water Coil • Mbh Capacities
Model 34RW

Unit Size 6

1 Row (single circuit)

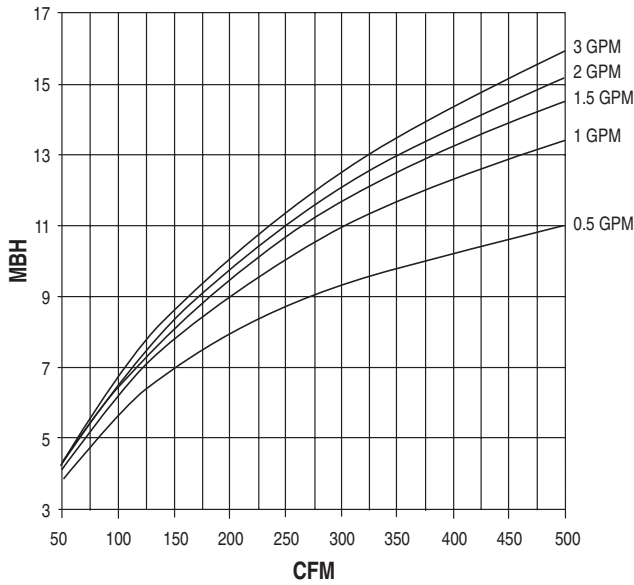

2 Row (multi-circuit)

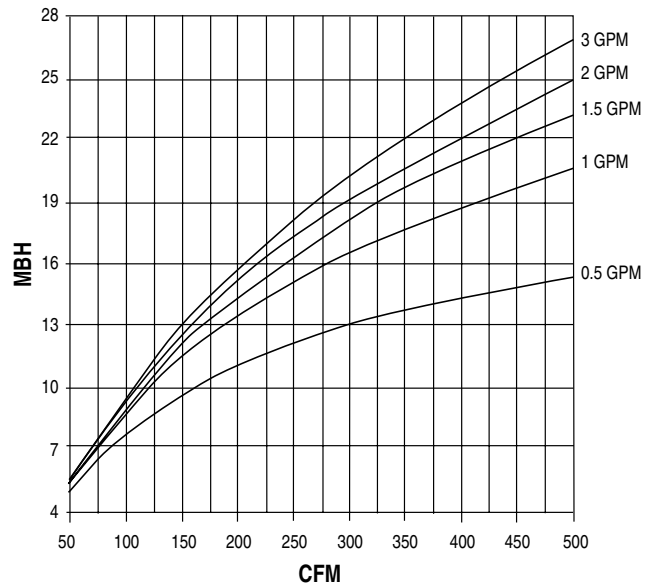

Unit Size 8

1 Row (single circuit)

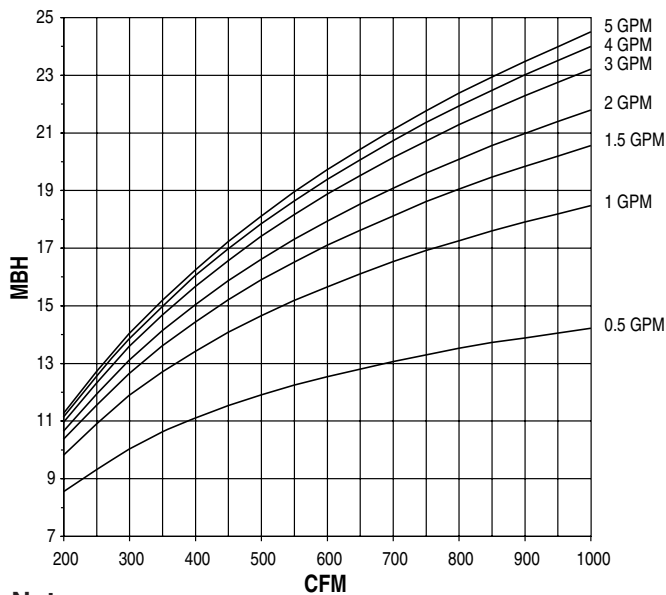

2 Row (multi-circuit)

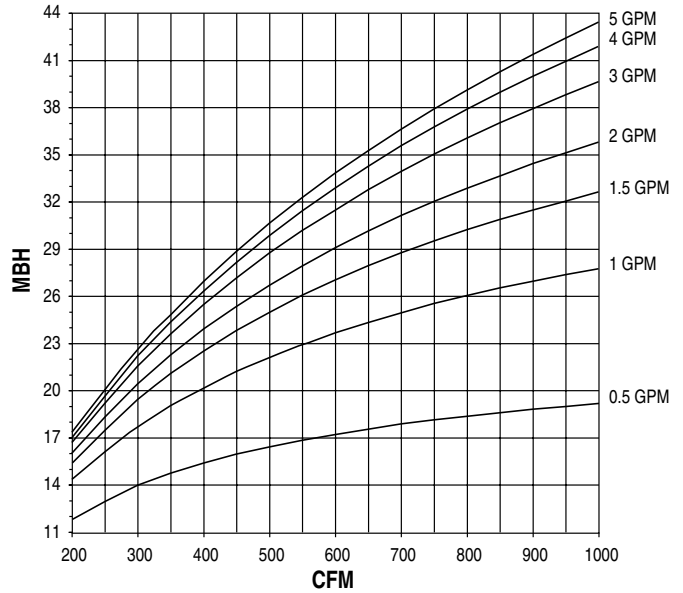

Notes:

- Capacities are in Mbh (thousands of Btu per hour).
- Mbh values are based on a Δt (temperature difference) of 125°F between entering air and entering water. For other Δt 's; multiply the Mbh values by the factors below.
- Air Temperature Rise. $ATR = \frac{927 \times \text{Mbh}}{\text{cfm}}$
- Water Temp. Drop. $WTD = \frac{2.04 \times \text{Mbh}}{\text{GPM}}$
- Connections: 1 Row 1/2"(13), 2 Row 7/8"(22); O.D. male solder.

Correction factors at other entering conditions:

Δt °F	40	50	60	70	80	90	100	110	125	140	160	180
FACTOR	0.32	0.40	0.48	0.56	0.64	0.72	0.80	0.88	1.00	1.12	1.28	1.44

Altitude Correction Factors:

Altitude (ft.)	Sensible Heat Factor
0	1.00
2000	0.94
3000	0.90
4000	0.87
5000	0.84
6000	0.81
7000	0.78

Performance Data Hot Water Coil • Mbh Capacities Model 34RW

Unit Size 10

1 Row (single circuit)

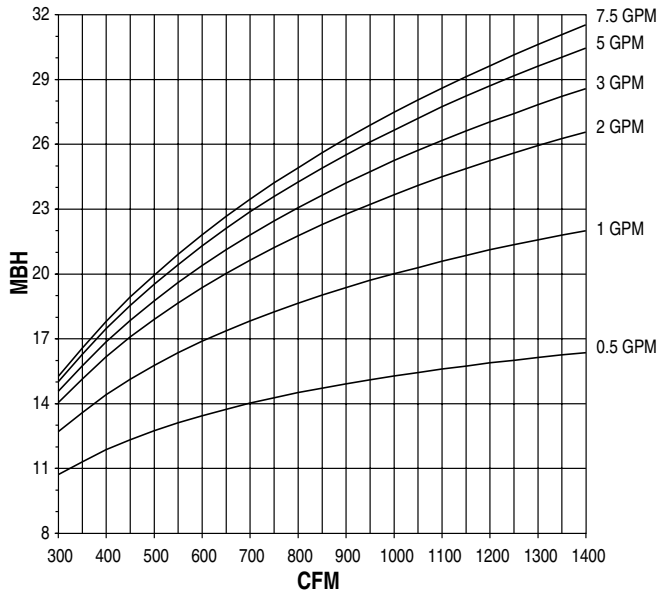

2 Row (multi-circuit)

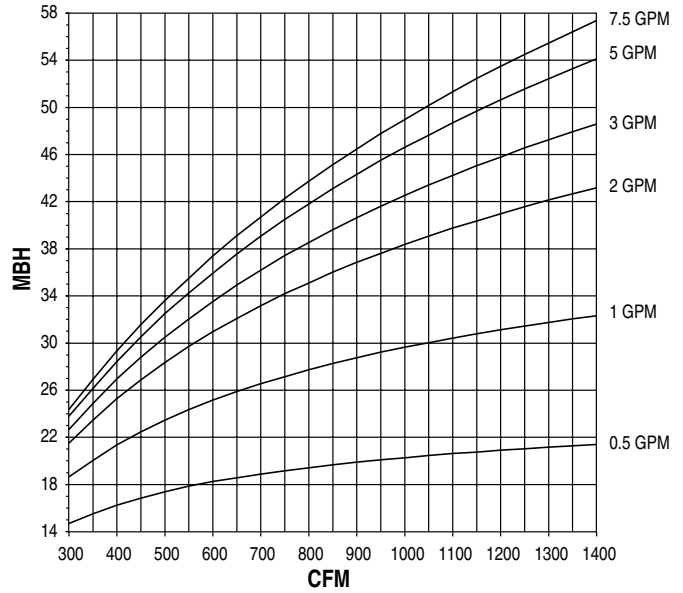

Unit Size 12

1 Row (single circuit)

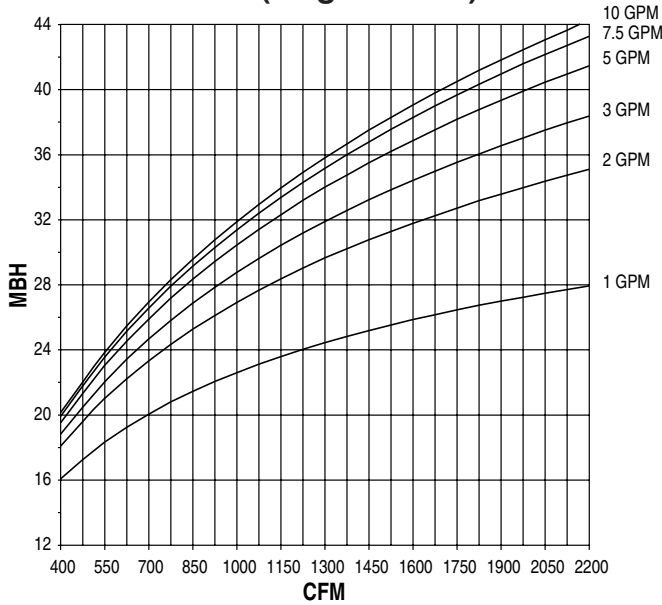

2 Row (multi-circuit)

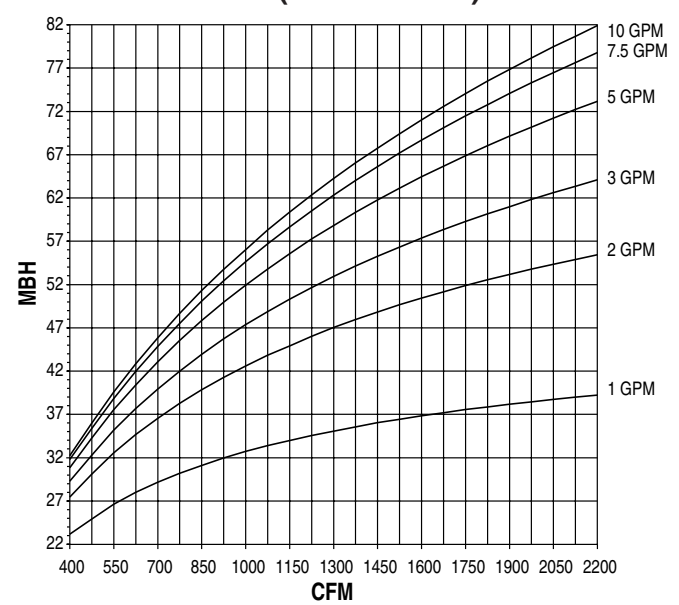

Notes:

- Capacities are in Mbh (thousands of Btu per hour).
- Mbh values are based on a Δt (temperature difference) of 125°F between entering air and entering water. For other Δt 's; multiply the Mbh values by the factors below.
- Air Temperature Rise. $ATR = 927 \times \frac{Mbh}{cfm}$
- Water Temp. Drop. $WTD = 2.04 \times \frac{Mbh}{GPM}$
- Connections: 1 Row 1/2" (13), 2 Row 7/8" (22); O.D. male solder.

Correction factors at other entering conditions:

Δt °F	40	50	60	70	80	90	100	110	125	140	160	180
FACTOR	0.32	0.40	0.48	0.56	0.64	0.72	0.80	0.88	1.00	1.12	1.28	1.44

Altitude Correction Factors:

Altitude (ft.)	Sensible Heat Factor
0	1.00
2000	0.94
3000	0.90
4000	0.87
5000	0.84
6000	0.81
7000	0.78



Performance Data Hot Water Coil • Mbh Capacities Model 34RW

Unit Size 14

1 Row (single circuit)

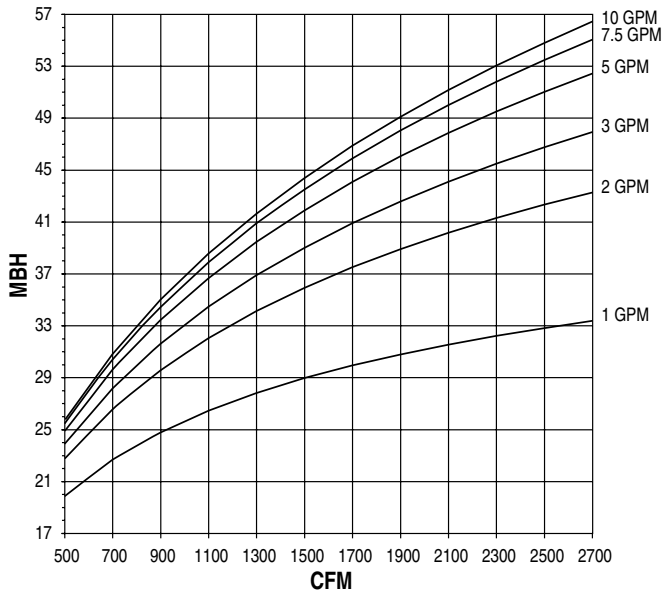

2 Row (multi-circuit)

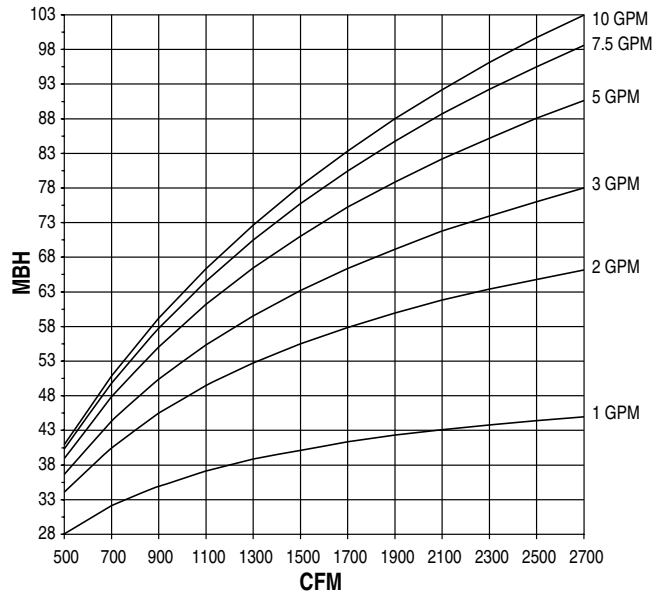

Unit Size 16

1 Row (single circuit)

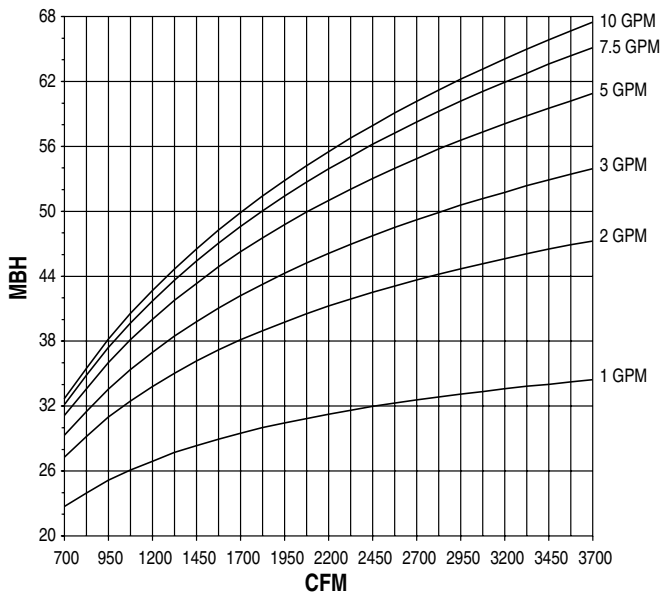

2 Row (multi-circuit)

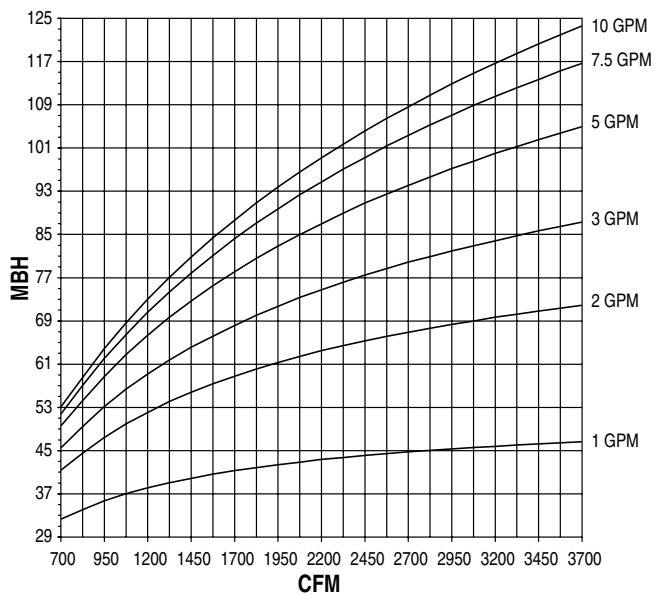

Notes:

- Capacities are in Mbh (thousands of Btu per hour).
- Mbh values are based on a Δt (temperature difference) of 125°F between entering air and entering water. For other Δt 's; multiply the Mbh values by the factors below.
- Air Temperature Rise. $ATR = 927 \times \frac{Mbh}{cfm}$
- Water Temp. Drop. $WTD = 2.04 \times \frac{Mbh}{GPM}$
- Connections: Size 14 – 1 Row 1/2" (13), all others – 7/8" (22); O.D. male solder.

Correction factors at other entering conditions:

Δt °F	40	50	60	70	80	90	100	110	125	140	160	180
FACTOR	0.32	0.40	0.48	0.56	0.64	0.72	0.80	0.88	1.00	1.12	1.28	1.44

Altitude Correction Factors:

Altitude (ft.)	Sensible Heat Factor
0	1.00
2000	0.94
3000	0.90
4000	0.87
5000	0.84
6000	0.81
7000	0.78

Performance Data Hot Water Coil • Pressure Drops Model 34RW

Unit Size 6

Unit Size 8

Water Pressure Drop

Air Pressure Drop

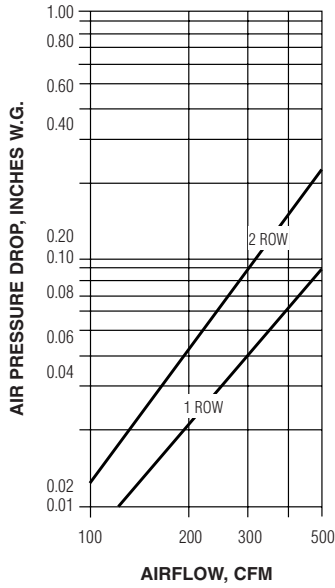
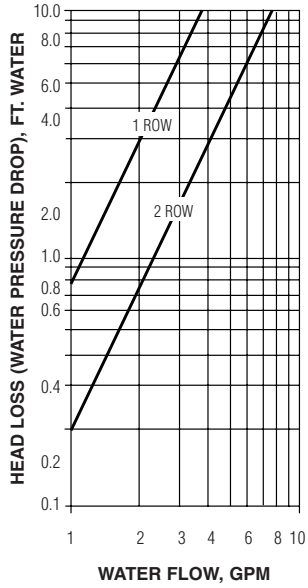

Water Pressure Drop

Air Pressure Drop

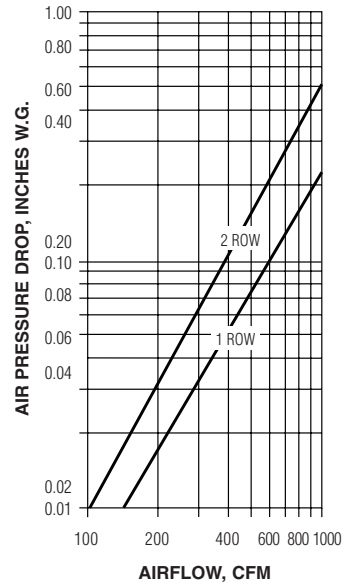
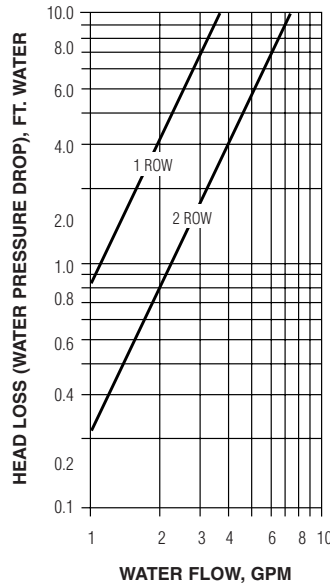

Unit Size 10

Unit Size 12

Water Pressure Drop

Air Pressure Drop

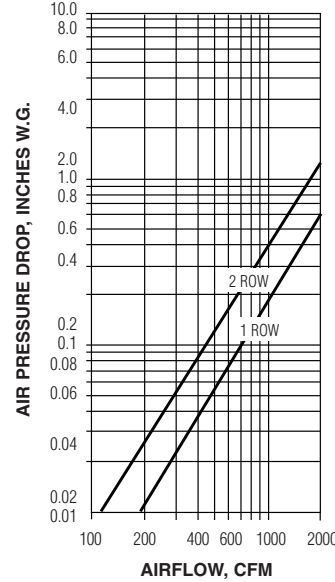
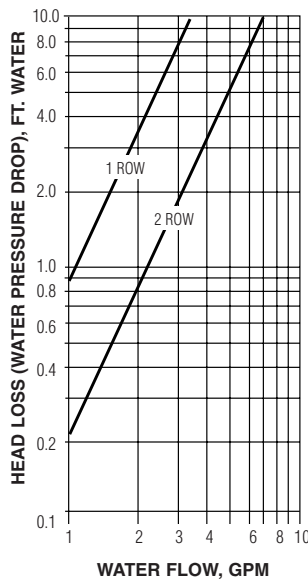

Water Pressure Drop

Air Pressure Drop

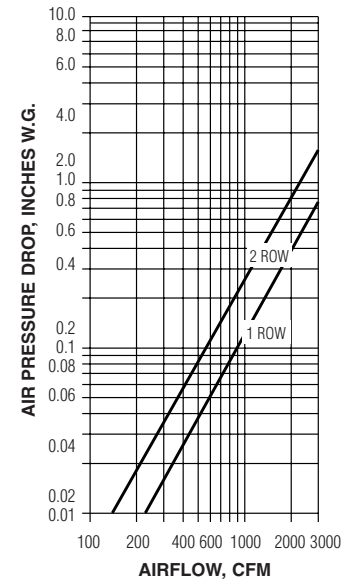
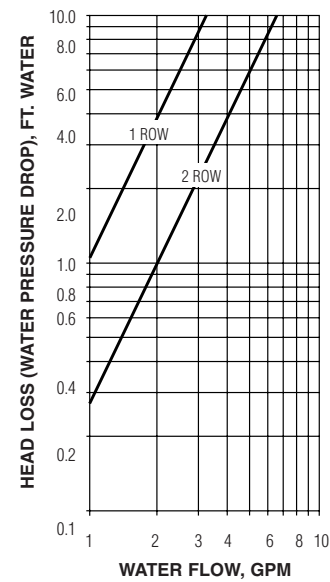

Metric Conversion Factors:

- Water Flow (liters per second)
 $l/s = gpm \times 0.6309$
- Water Head Loss (kilopascals):
 $kPa = ft. w.g. \times 2.9837$
- Airflow Volume (liters per second)
 $l/s = cfm \times 0.472$
- Air Pressure Drop (Pascals):
 $Pa = in. w.g. \times 248.6$
- Heat (kilowatts):
 $kW = Mbh \times 0.293$

Performance Data Hot Water Coil • Pressure Drops Model 34RW

Unit Size 14

Unit Size 16

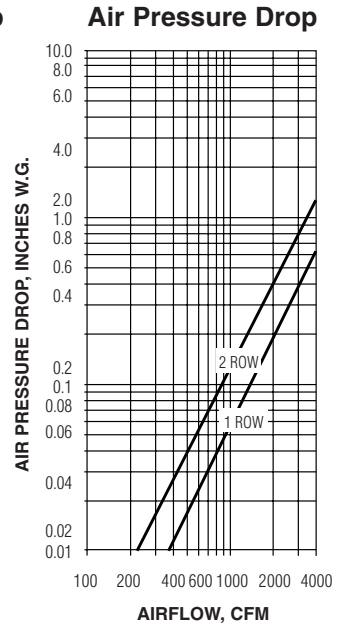
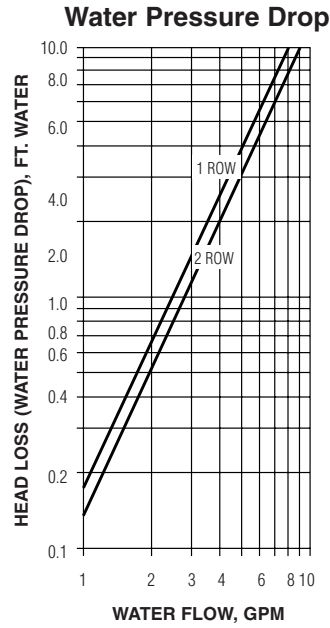
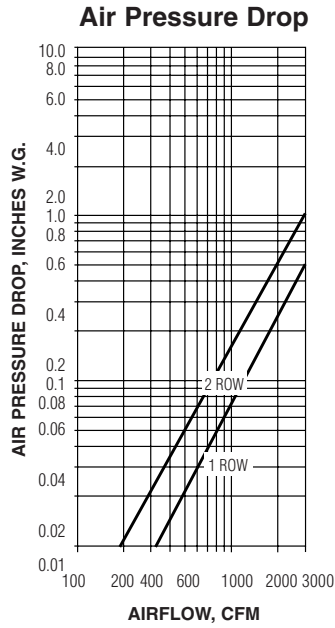
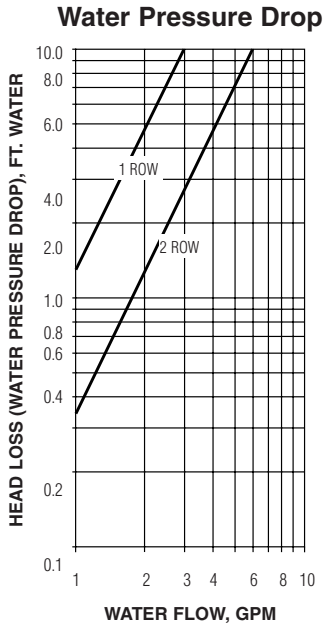

Metric Conversion Factors:

- | | |
|--|--|
| 1. Water Flow (liters per second)
l/s = gpm x 0.6309 | 4. Air Pressure Drop (Pascals):
Pa = in. w.g. x 248.6 |
| 2. Water Head Loss (kilopascals):
kPa = ft. w.g. x 2.9837 | 5. Heat (kilowatts):
kW = Mbh x 0.293 |
| 3. Airflow Volume (liters per second)
l/s = cfm x 0.472 | |



Electric Heating Coils • Selection and Capacities

Nailor manufactures its own electric heating coils. Electric heater element racks are enclosed in an insulated attenuator section which is shipped attached to the air terminal unit discharge. The location of the heater elements in the attenuator downstream of the air terminal provides adequate distance for the flow of supply air to expand once past the damper so that there are no hot spots in the heater.

For dimensional data, see page F6.

Standard Features:

- Primary auto-reset high limit thermal cut-out (one per coil in control circuit).
- Secondary manual reset high limit thermal cut-outs (one per element).
- Positive pressure airflow switch.
- Derated high quality nickel-chrome alloy heating elements.
- Magnetic or safety contactors and/or PE switches as required.
- Line terminal block.
- ETL Listed.
- Hinged door control enclosure.
- High performance arrowhead insulators.
- Slip and drive discharge connection.

Selection:

The adjacent table provides a general guideline as to the voltages and kilowatt range available for each terminal unit size.

Maximum kilowatt loading is 1 kW per 70 cfm (33 l/s) at heating condition.

A good design will hold the discharge temperature between 90 and 105°F (32 to 40.5°C). Never select kW to exceed a discharge temperature of 120°F (49°C) maximum for comfort heating.

$$\Delta t \text{ (air temp. rise, } ^\circ\text{F)} = \frac{\text{kW} \times 3160}{\text{cfm}}$$

The coil ranges listed are restricted to a maximum of 48 amps and do not require circuit fusing to meet NEC code requirements. Total pressure at the airflow switch should be at least 0.07" w.g. (17 Pa) to ensure correct coil operation and prevent cut-out due to insufficient airflow over the coil elements.

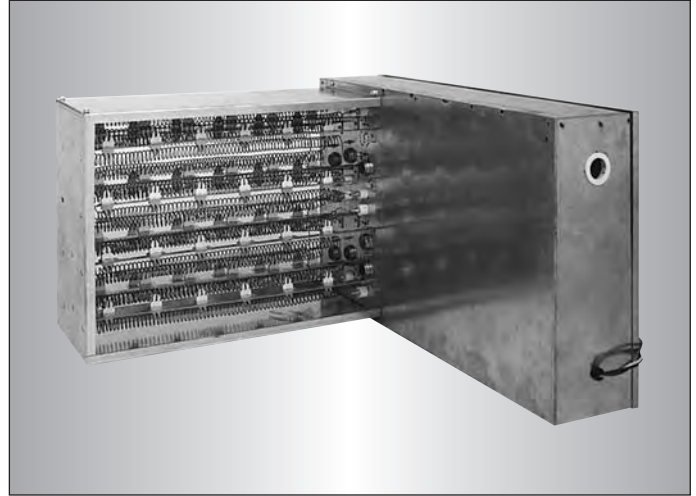

Options:

- Class 2, 24V control transformer.
- Mercury contactors.
- Toggle type disconnect switch.
- Door interlock disconnect switch.
- Power circuit fusing.
- Dust tight construction.
- SCR control.
- Class 'A' 80/20 wire.



Electric Coil Limitations	
Voltage/ Phase	kW Range
120/1	0.5 – 5.7
208/1	0.5 – 9.9
240/1	0.5 – 11.5
277/1	0.5 – 13.0
480/1	0.5 – 18.0
208/3	0.5 – 17.3
240/3	0.5 – 20.0
480/3	0.5 – 20.8
600/3	0.5 – 26.0

Balancing Procedure

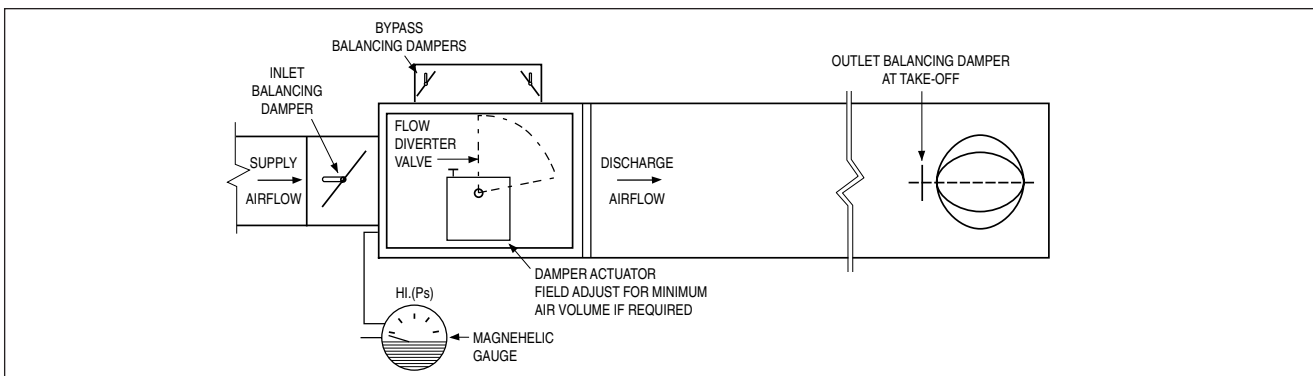

This balancing procedure assumes that the fan supplying the system maintains a constant static pressure in the supply duct to the terminal unit. Bypass terminal units are pressure dependent and will need rebalancing if system duct static pressure changes.

The 3400 series are shipped with both inlet and bypass balancing dampers as standard to permit ease of field balancing and to ensure accurate adjustment and optimum operation.

1. Fully open the dampers of all supply outlets on the discharge duct from the terminal unit.
2. Place terminal in the full open position, supplying 100% air to the occupied space by adjusting the thermostat to full cooling.
3. Adjust the balancing damper located in the terminal inlet to provide the required total airflow.
4. Starting with the outlet furthest downstream, adjust the damper of each air outlet to the required air volume.
5. Take a static pressure reading at the terminal unit after the inlet damper, using a magnehelic gauge or equivalent.
6. Adjust the room thermostat to full heating to provide 100% bypass airflow or the minimum air volume to the room, if a mechanical minimum air volume stop is utilized. An indicator mark on the end of the driveshaft shows damper position, 90° rotation CW to close.
7. Adjust the bypass outlet damper(s) on the terminal until the static pressure reading equals that obtained in step 5.
8. Re-adjust the room thermostat to the desired setpoint temperature. The terminal is now balanced.

Mechanical Minimum Stop Field Setting Procedure

Pneumatic Actuator (MCP-3631 Series)

Actuator rotation is 100°. Angle of rotation can be limited by inserting a 1/4" – 20 stroke stop screw into front end of actuator and securing with a lock nut (field supplied by user). Length of screw is unimportant as long as it has adequate thread length. Damper rotates 90°, CW to close and has built in end stops.

Desired Rotation	Insertion of Stop Screw
95°	0.520" (13.2)
85°	0.700" (17.8)
75°	0.875" (22.2)
65°	1.050" (26.7)
55°	1.220" (40.0)
45°	1.400" (35.6)

1. Direct acting/normally closed damper connection: Disconnect control air to actuator. Ensure damper and actuator are in alignment. Damper should be fully closed.

- (a) Using mechanical minimum stop. Adjust screw to back-off damper to required minimum airflow position.
- (b) Using damper end stops (no mech. minimum stop provided). Loosen collar set and bushing on damper shaft. Rotate damper shaft CCW to desired minimum airflow position and re-tighten actuator connection.

2. Reverse acting/normally open damper connection:

- (a) Using stroke stop screw. Apply 20 psi main air to actuator. Insert screw (by others) and back-off damper to required minimum airflow position.
- (b) Using damper end stops (no built-in stroke stop screw). Loosen damper/actuator collar set and bushing coupling. Apply 20 psi main air to actuator. When actuator reaches the end of its rotation, rotate damper shaft CCW to desired minimum airflow position and re-tighten on shaft.

Electric Actuators

KMC MEP-5071 (standard). Position damper to the full open position. Depress the gear disengagement button and position the drive collar so the indicator mark is at the "90" mark. Tighten setscrews on shaft. Loosen lower travel stop one-half turn and slide to desired position. Tighten stop screw.

Honeywell ML6161B-2024 (optional). Use clutch to position damper in fully open position. Insert setscrew with lock nut (supplied) in the threaded hole in top left corner of actuator, turning CW until fully inserted. With setscrew fully inserted, minimum position is 30°, fully out 0°. Use conversion of approx. 1.7 angular degrees per turn of the setscrew. Back screw out of housing and stop slightly short of the calculated position. This allows the setscrew to be set accurately while taking airflow measurements. (Important: Do not back-drive actuator with setscrew, damage may result.) Rotate actuators to minimum position using the manual declutch. Accurately set minimum flow by backing-off setscrew as required using airflow measurement. Using locknut, secure against actuator housing to lock setscrew in place.

Suggested Specifications

Model Series 3400 Mk II

General Information

Provide Model Series 3400 Mk II variable air volume bypass terminal units as manufactured by Nailor Industries. Performance and capacities shall be as scheduled on the drawings.

Construction

Unit casing shall be constructed of 22 gauge zinc coated steel, acoustically and thermally lined with 3/4" (19) dual density insulation which meets the requirements of Standard NFPA 90A and UL 181. Units shall incorporate a heavy duty steel cylindrical "flow diverter" valve. Single blade pivoting dampers are not acceptable.

Units shall include integral inlet and bypass balancing dampers for field adjustment as standard components. Static pressure taps shall be provided to facilitate balancing.

Pneumatic Controls

The control sequence shall be Direct acting (normally closed damper) or Reverse acting (normally open damper). All pneumatic actuators shall be furnished and factory installed by Nailor.

Analog Electronic Controls

Units shall be provided with a modulating electronic control package. The 24 volt reversible actuator shall be factory mounted direct to the damper shaft and shall include an adjustable minimum air volume end stop as a standard feature.

The 24 volt modulating electronic thermostat for field mounting shall be supplied with a (°C) (°F) temperature scale. The thermostat shall be suitable for vertical wall mounting.

The thermostat shall be microprocessor based and provide proportional plus integral control of airflow and reheat when specified.

A 115 to 24 volt 20 VA transformer shall be provided, complete with all necessary hardware for field mounting.

A changeover thermistor shall be provided with control packages designed to control both heating and cooling supply air.

Water Reheat Coils

Hot water reheat units as scheduled shall include 1-row and/or 2-row coils. Coil capacities shall be as scheduled. A low-leakage access door shall be provided to allow cleaning and inspection of the coil. Coils shall be factory mounted on the discharge of the unit with slip and drive connections.

The coils shall be aluminum plate fin with copper tubes and sweat connections. Coil connections shall be right hand or left hand as detailed on drawings. Control valves, automatic air vents and drain vents, if required, shall be supplied and field installed by others.

Electric Reheat Coils

Electric reheat coils shall be ETL listed. They shall be factory mounted on the unit discharge in an extended attenuation section. Heating capacities and control components shall be as scheduled on the drawings.