

#### APPLICATIONS:

*Specified Comfort is suitable for renovation, upgrade and new construction projects.*

- Commercial Offices
- Educational Facilities
- Worship Facilities
- Research Facilities
- Retail Locations
- Hospitality & Restaurants

#### FEATURES:

- Remote monitoring and control of lighting, HVAC, fans, networked PCs and plug devices
- Metering and demand response
- Optional connectivity to Modbus and BACnet
- Easy to install and configure: simply mount, connect, power and go!
- Secure wireless 2.4GHz ZigBee communications with other network devices
- Data storage retains all system events for over one year; event data can be analyzed to optimize energy use and savings
- Scalable to manage a single building or an entire campus
- Graphical view of real-time and historical energy use provides comprehensive and actionable information to users
- Specified Comfort products operate independently or as an integrated solution
- Made in the USA (ARRA Compliant)



#### DESCRIPTION:

The Specified Comfort SC-EMS-TM Energy Manager from Specified Controls is a rugged, industrial control processor that is the heart of innovative integrated energy management systems powered by Specified Comfort software. The Energy Manager coordinates all energy management functions utilizing Specified Comfort wireless network.

The compact Specified Comfort SC-EMS-TM Energy Manager receives input from environmental sensors, local controls and metering devices throughout a facility. Based upon sensor input, schedule, local input, curtailment, and event information, adjustments to lighting, HVAC, fans, networked PCs and plug devices are implemented in real time to minimize energy waste.

Communication with other Specified Comfort Meters, the Specified Comfort Energy Manager running metering software and other Specified Comfort devices (such as lighting and HVAC controls) is via a reliable wireless mesh network.

## SPECIFICATIONS:

### APPLIANCE

Mounting: Wall bracket or table-top  
 Storage: SATA 2.5" hard drive  
 Endpoint Capacity: ~300, upgradable to 1000  
 Operating System: Secure Linux-based variant

### POWER SUPPLY

Voltage: 120VAC input/ 12VDC output  
 Power: 20 watts max

### I/O SUPPORT

LAN: 1x10/ 100/ 1000 Ethernet, TCP/ IP v4  
 UDP ports: 49657, 54261, 59370, 59371  
 Serial: 2 - 1 dedicated internal, 1 open  
 USB: 2 USB 2.0 host interfaces

### PROTOCOLS

Serial: Modbus, RS-485, MS/ TP  
 Wireless: 802.15.4 with mesh networking  
 Ethernet: HTTP/ HTTPS  
 Security: Internal firewall, isolated wireless and internal processors

### RADIO NETWORK

IEEE 802.15.4-2003 2.4GHz ISM (ZigBee)  
 Range: Approx. 1000' LOS transmit/ receive

### REGULATORY APPROVALS

UL 60950  
 FCC (V8NZRB1000141) & IC (7737A-ZRB1000141),  
 Certified Class B  
 Digital Device, FCC Part 15

### ENVIRONMENTAL

Operating Temperature: 50° to 104°F  
 Storage Temperature: -13° to 149°F

### PHYSICAL

Dimensions (HxWxD): 10.75 x 9.94 x 2.5in (27.31 x 25.25 x 6.35cm)  
 Color: Blue  
 Weight: 5.0lbs (2.68kg)

## ORDERING INFORMATION:

SKU	Description
Appliances as shown include wall-mounted Specified Comfort Manager with Specified Comfort Software, which includes thermostat, lighting, metering, and fan software. Specified Comfort Manager includes Ethernet and Specified Comfort wireless interfaces.	
SC-EMS-TM	Specified Comfort Energy Manager with Specified Comfort Software (For up to 100 Devices)
SC-EMS-TM-PLUS	Specified Comfort Energy Manager with Specified Comfort Software (For up to 400 Devices)
Optional Accessories:	
SC-EMS-TIS	Tridium Interface Software Supports TCP/IP connectivity via Tridium Niagara AX Platform or ModBus
SC-EMS-PRO	Add Specified Comfort PRO Advanced Automation Tools to Specified Comfort Energy Manager

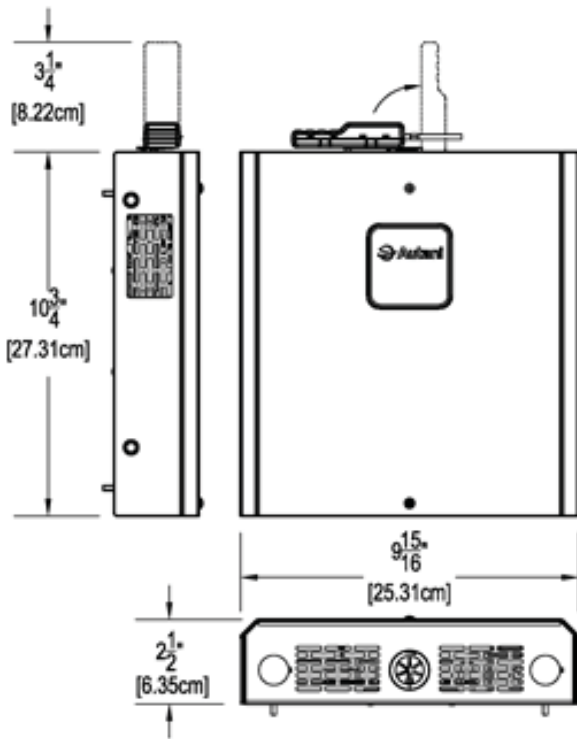

**MULTI-SITE CONNECTIVITY:**

Specified Comfort’s Portfolio Manager is a hosted software solution for managing the temperature, lighting and energy consumption of multi-site facilities. Using a secure, web-based interface that connects two or more Specified Comfort systems, Portfolio Manager directs schedules, alerts and demand response events across multiple premises.



**THE SPECIFIED COMFORT FAMILY ENERGY MANAGEMENT DONE RIGHT**

The Specified Comfort product line from Specified Controls integrates lighting, climate control, fans, metering, and plug loads to provide a powerful integrated energy management solution. The lighting, thermostat, fan control and metering software share the Specified Comfort Energy Manager and operate as an integrated application.

Specified Comfort software communicates via the Specified Comfort Energy Manager to lighting controllers, motion sensors, thermostats, fans, meters and plugs using a secure wireless 2.4GHz ZigBee communications network.

**SPECIFIED COMFORT SC-EMS-TM MANAGER CONNECTIVITY:**

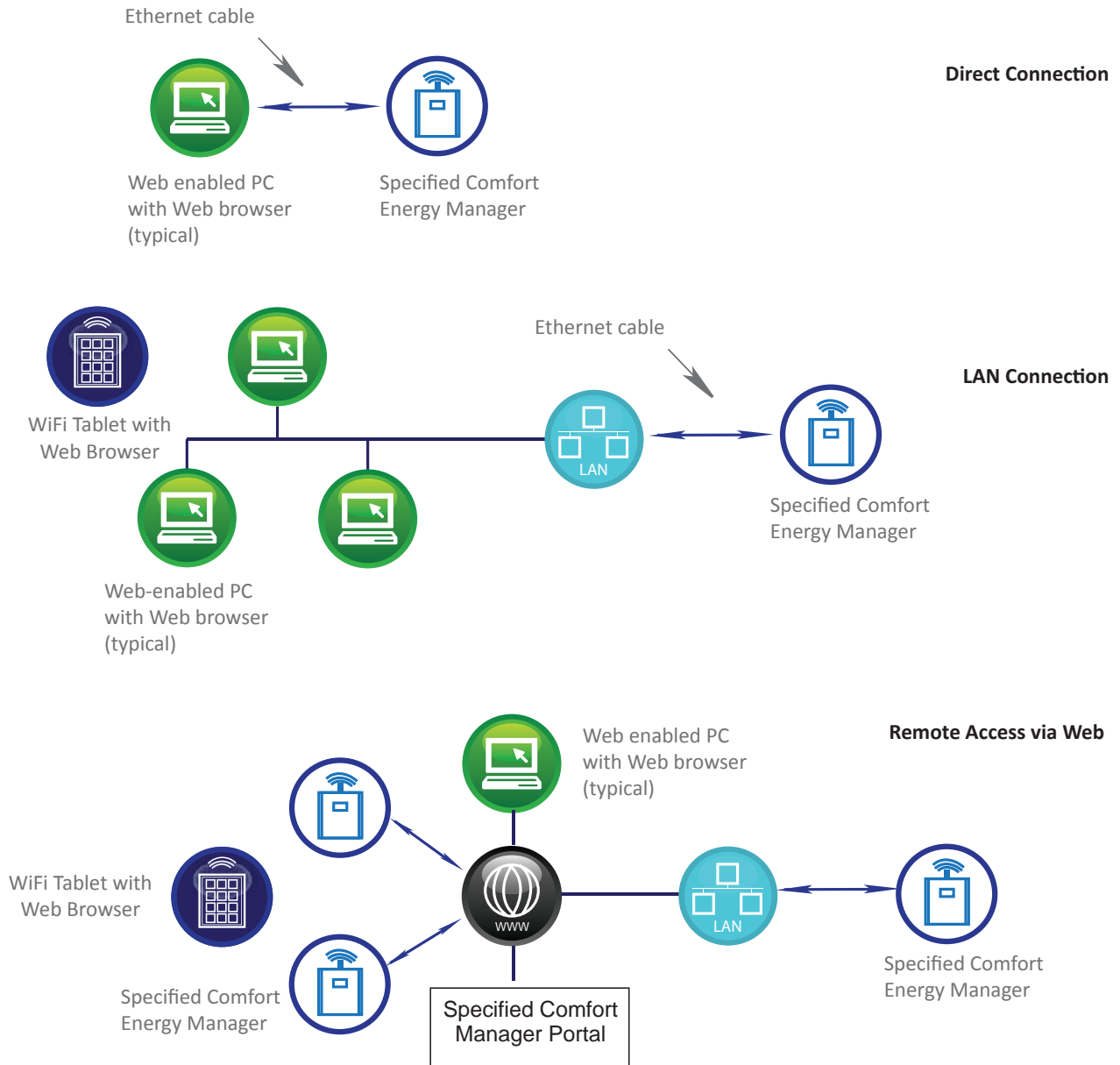

#### APPLICATIONS:

*Specified Comfort is suitable for renovation, upgrade and new construction projects.*

- Commercial Offices
- Educational Facilities
- Worship Facilities
- Research Facilities
- Retail Locations
- Hospitality & Restaurants

#### FEATURES:

- Integrated Modbus transceiver with factory wiring harness included
- Easy front panel access for transceiver diagnostics
- Universal applications
- Easy to install and configure: simply mount, connect, power and go!
- Secure wireless 2.4GHz ZigBee communications with other network devices
- Scalable to manage a single building or an entire campus
- Graphical view of real-time and historical energy use provides comprehensive and actionable information to users
- Specified Comfort products operate independently or as an integrated solution
- Made in the USA (ARRA Compliant)



#### DESCRIPTION:

The Specified Comfort SC-EMS-T32-P Thermostat from Specified Controls is a rugged, industrial control that communicates with the Specified Comfort Energy Manager. This universal thermostat features an integrated Modbus transceiver that connects to the Specified Comfort Energy Manager through a secure Zigbee mesh network. This design allows each thermostat to communicate with other thermostats, extending the range and ensuring a strong and reliable signal.

The integrated transceiver with factory wiring harness reduces installation time and eliminates miss-wiring. Additionally, it provides easy access for transceiver diagnostics without having to remove the thermostat sub base.

### SPECIFICATIONS:

#### ELECTRICAL

Input Voltage: 24VAC 50/60 Hz +/- 15%

Relay Rating: 24VAC @ 1 amp max. per relay

#### WIRELESS COMMUNICATION

Zigbee

#### PROTOCOL

Modbus

#### APPROVALS

FCC Part 15 C-tick

#### ENVIRONMENTAL

Operating Temperature: 32° to 122°F

Operating RH: 0 - 95% (non-condensing)

#### BACKLIGHT

Blue EL (Electro Luminescent)

#### PHYSICAL

Dimensions (HxWxD): 5.50 x 4.375 x 1 in

Color: White

Weight/ Shipping Weight: <10 oz/ <11lb

#### TERMINAL DESIGNATIONS

W2 – Second Stage Heating or Auxiliary Heat

Y2 – Second Stage Compressor

W1-O/B – First Stage Heating or Reversing Valve

Y1 – First Stage Compressor

G – Fan Relay

R – 24 Volt Hot (jumpered to '24')

24 – 24 Volt Hot (jumpered to 'R')

24C – 24 Volt Common

B – Modbus Communications

A – Modbus Communications

T – Remote Sensor

### ORDERING INFORMATION:

SKU	Description
SC-EMS-T32-P	Specified Comfort Wireless Communicating Thermostat
Optional Accessories:	
SC-EMS-DAS	Specified Comfort Wireless Duct Air Sensor
SC-EMS-REP	Specified Comfort Wireless Range Extender with power supply



Traneiver Front Access

### DIP SWITCH FUNCTIONS:

SWITCH #	OFF	ON
1 Not used	Leave OFF	—
2 Equipment	Heat/Cool	Heat Pump
3 Equipment Mode	Single Stage	Multi-Stage
4 Fan Mode or Reversing Valve	Gas "O"	Electric "B"

SWITCH #	OFF	ON
5 Short Cycle Timer	4 Minutes	Disabled
6 Thermostat Operations	Leave OFF	—
7 Minutes Run Time	Leave OFF	—
8 Setpoints	—	Leave ON

### APPLICATIONS:

Specified Comfort Energy Management System is suitable for renovation, upgrade and new construction projects.

- Commercial Offices
- Educational & Worship Facilities
- Manufacturing & Warehouse Facilities
- Retail Locations

### FEATURES:

- 120VAC power supply
- UL Listed & Plenum Rated
- Made in the USA (ARRA Compliant)
- Range: Approx. 1000' LOS transmit/receive

### SPECIFICATIONS:

#### ELECTRICAL

Input Voltage: 12 to 30VDC  
 Input Current: 20 to 100mA

#### RADIO NETWORK

IEEE 802.15.4-2003 2.4GHz ISM (ZigBee)  
 Range: Approx. 1000' LOS transmit/ receive  
 REGULATORY APPROVALS  
 FCC (V8NZRB1000141) &  
 IC (7737A-ZRB1000141)

#### ENVIRONMENTAL

Test condition of all ratings 77°F  
 Operating Temperature: 32° to 158°F  
 Storage Temperature: -13° to 176°F

#### PHYSICAL

Dimensions (HxWxD): 3.35 x 1.07 x .71in  
 Color: White  
 Weight/ Shipping Weight: <10 oz/ <1lb



### DESCRIPTION:

The Specified Comfort SC-EMS-REP Range Extender is a wirelessly connected 120VAC plenum rated repeater used to extend the range of the Specified Comfort Energy Manager signal within or between structures.

Up to 100 number of range extenders can be used with a Specified Comfort Energy Management Systems. The SC-EMS-REP is recognized as a device by the Specified Comfort Manager.

### ORDERING INFORMATION:

SKU	Description
SC-EMS-REP	Range Extender with power supply

### DIMENSIONS:

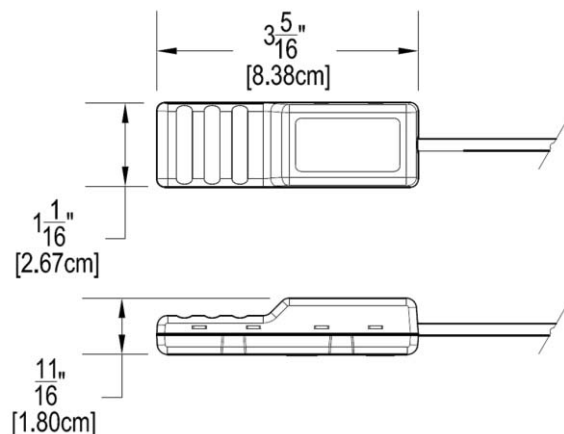





#### APPLICATIONS:

*Specified Comfort Wireless Lighting Controller is suitable for renovation, upgrade and new construction projects.*

- Commercial Offices
- Educational & Worship Facilities
- Manufacturing & Warehouse Facilities
- Retail Locations

#### FEATURES:

- Multi-Voltage Compatible, 120 to 347VAC
- Control of up to ten 0-10VDC dimmable fluorescent or LED lighting fixtures (Advance Mark 7 ballast or equivalent)
- Suitable for individual fixture control or zone based control schemes
- Sensor input for selected 0-10VDC photocells to support daylight harvesting with an unlimited number of targets or setpoints
- Local control input for selected 0-10VDC dimmer controls
- Dimming for lumen maintenance provides constant output over the life of selected LED fixtures
- Assignable guardband and delay for daylight harvesting applications to prevent unwanted changes in light level
- Connected sensors and controls function locally if Network Communications are lost
- Supports EnOcean wireless switches, contacts, sensors and key card holders
- UL Listed & Plenum Rated
- Made in the USA (ARRA Compliant)



#### DESCRIPTION:

The Specified Comfort SC-EMS-AFC-A Dimming Fixture Controller is a wirelessly managed 120/277/347VAC plenum rated lighting controller with integrated daylight harvesting support.

In addition to schedules and demand response events enacted by Specified Comfort software, the SC-EMS-AFC-A can be deployed with local control, daylight harvesting control, or both. A standard power pack such as the Specified Comfort UVPP powers the Fixture Controller and provides a low end cutoff relay for connected loads.

Using Specified Comfort, occupancy detected by sensors connected to networked Room Controllers (like the SC-EMS-ARC-R) can be used to determine light level, daylight harvesting setpoints, or maximum light level. Specified Comfort's dimming records actual light levels as they are set, providing flawless, repeatable performance even if the light source degrades.

As a network device, the SC-EMS-AFC-A is controlled by a Specified Comfort Manager running the lighting control software. The lighting control software manages lighting circuits based upon time schedules, local control, occupancy, light levels, demand response curtailments, computer activity and door openings or closures.

**SPECIFICATIONS:**

**ELECTRICAL**

Input Voltage: 12 to 30VDC  
 Input Current: 20 to 100mA  
 Output Voltage: 10V  
 Output Current: 1mA  
 0-10VDC Analog Input (Channel 1 and 2): 0 to 10V  
 0-10VDC Analog Output: 0 to 10V

**I/O PORTS**

Channel 1: 0-10VDC Daylight Sensor/ Photocell  
 Channel 2: 0-10VDC Local Dimmer Control

**RADIO NETWORK**

IEEE 802.15.4-2003 2.4GHz ISM (ZigBee)  
 Range: Approx. 1000' LOS transmit/ receive  
 REGULATORY APPROVALS

FCC (V8NZRB1000141) &  
 IC (7737A-ZRB1000141)

**ENVIRONMENTAL**

Test condition of all ratings 77°F  
 Operating Temperature: 32° to 158°F  
 Storage Temperature: -13° to 176°F

**PHYSICAL**

Dimensions (HxWxD): 3.35 x 1.07 x .71in  
 Color: White  
 Weight/ Shipping Weight: <10 oz/ <1lb

**DIMENSIONS:**

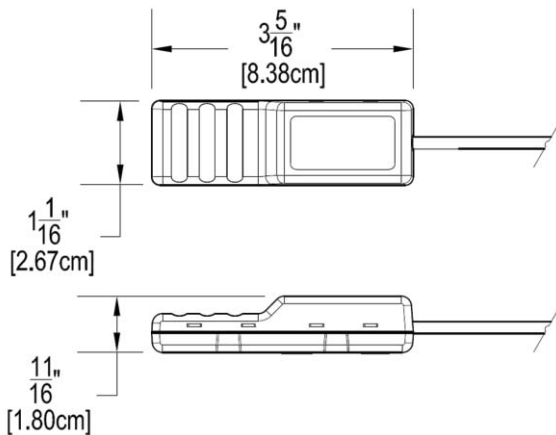

**ORDERING INFORMATION:**

SKU	Description
SC-EMS-AFC-A	Dimming Fixture Controller, 0-10VDC interface, 120 to 347VAC (requires UVPP for power and low end cutoff)

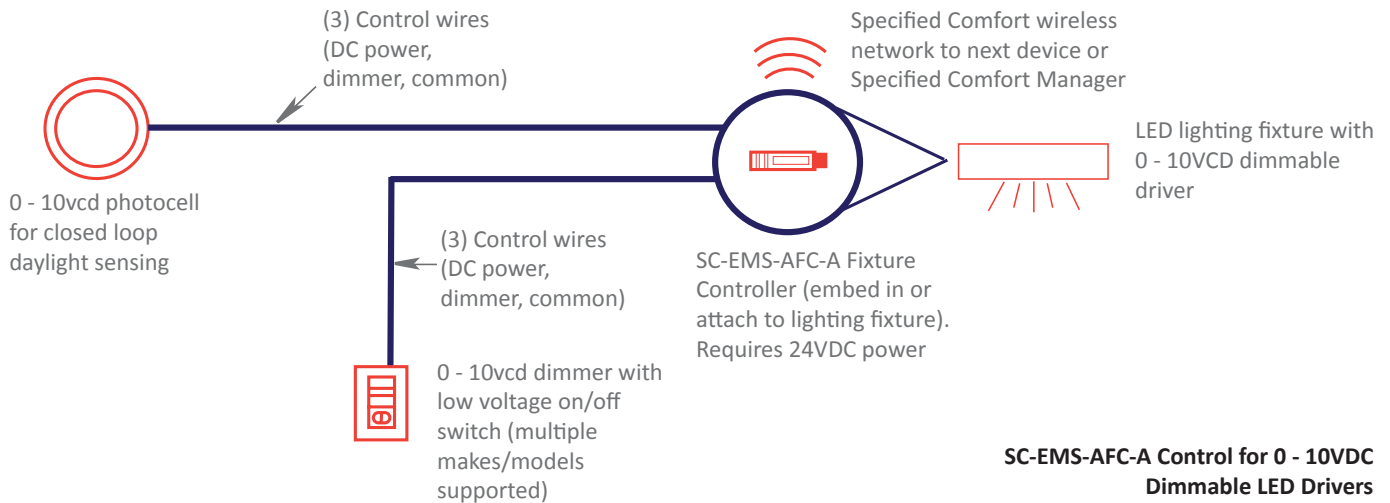
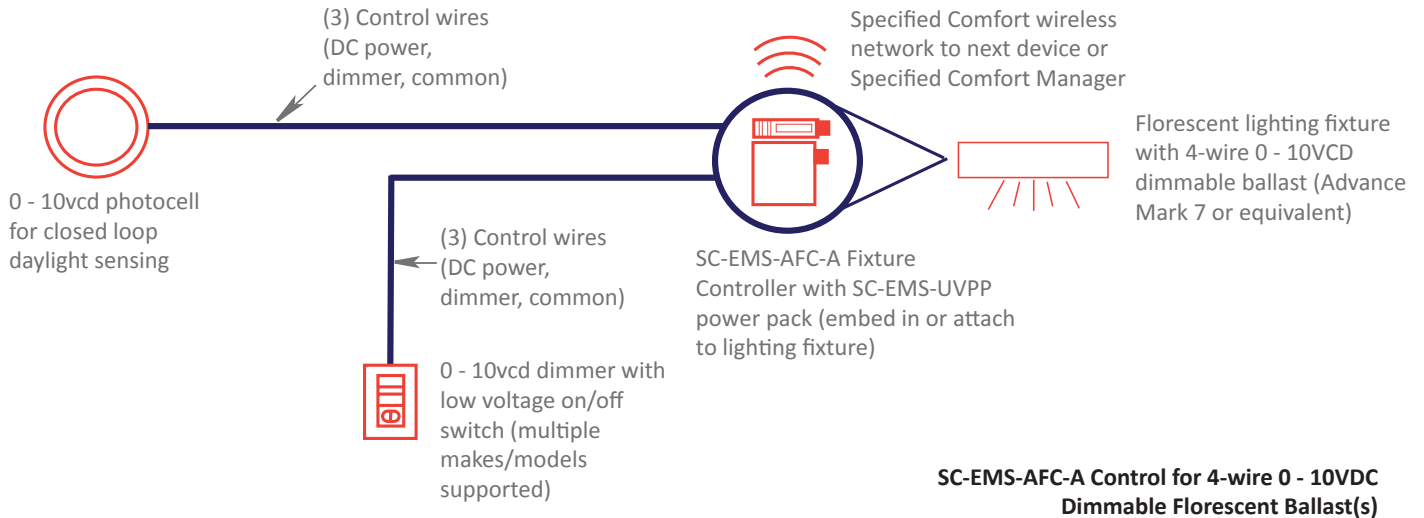



#### APPLICATIONS:

*Specified Comfort Wireless Lighting and Load Controllers are suitable for renovation, upgrade and new construction projects.*

- Commercial Offices
- Educational & Worship Facilities
- Research Facilities
- Retail Locations
- Hospitality & Restaurants

#### FEATURES:

- Multi-Voltage Compatible, 120 to 277VAC
- Integrated control of one 20A circuit with control of 2nd circuit via optional outboard power pack
- Plenum-Rated device promotes an efficient, distributed control strategy
- Secure wireless 2.4GHz ZigBee communications with other network devices
- Supports the Specified Comfort range of wired and wireless occupancy sensors, including door and window contacts
- Local control via standard light switches and contact closures; 3-way and 4-way switching configurations are supported
- Connected sensors and switches function locally if network communications are lost
- The SC-EMS-ARC switched controller is an independent system that also integrates with other members of the Specified Comfort family
- Supports EnOcean wireless switches, contacts, sensors and key card holders
- UL Listed & Plenum Rated
- Made in the USA (ARRA Compliant)



#### DESCRIPTION:

The Specified Comfort SC-EMS-ARC Switched Lighting and Load Controllers are wirelessly managed 120/277VAC plenum-rated controllers. The SC-EMS-ARC provides managed control of up to two independent switched circuits, supporting the second circuit via an external power pack.

Compatible with the Specified Comfort SC-EMS-ARC range of wired and wireless occupancy sensors, the SC-EMS-ARC also provides connectivity for door and window contacts. The room controller can be operated in stand-alone mode (as a standard switched power pack) or as part of a Specified Comfort Integrated Lighting Management System using the Specified Comfort wireless mesh network.

As a network device, the SC-EMS-ARC is controlled by a Specified Comfort Manager running the lighting software. The software manages lighting circuits based upon time schedules, local control, occupancy, demand response curtailments, light level, computer activity and door openings or closures.

### SPECIFICATIONS:

#### ELECTRICAL

Operating Voltage: 100 to 277VAC  
 Operating Current: 15mA typ./ 75mA max. @ 120VAC  
 DC Output (77°C): 12VDC typ., 100mA  
 Switching Capacity: 20A max. (resistive load)

#### INTERNAL RELAY (77°C)

Max. Switching Power: 8310VA  
 Max. Switching Voltage: 277VAC  
 Max. Switching Current: 20A

#### I/O PORTS

Total power budget for all I/O ports is 120mA  
 Power Pack: 24VDC typ., 150mA  
 DC Output: 12VDC typ., 100mA  
 Contact: 12VDC typ., 100mA  
 Sensor: 3.0VDC for Web Comfort MINI Wired Sensor

#### LOCAL CONTROL INPUTS

Wall Switch: (1) contact closure  
 Door Contact/ 2nd switch: (1) contact closure  
 Sensor: Up to (10) MINI Wired Sensors

#### RADIO NETWORK

IEEE 802.15.4-2003 2.4GHz ISM (ZigBee)  
 Range: Approx. 250' LOS transmit/ receive

#### REGULATORY APPROVALS

UL 916 CSA C22.2 No. 205 (Listing E113003)  
 UL 2043 Plenum Rated  
 FCC (V8NARC1000133)  
 IC (7737A-ARC1000133)

#### ENVIRONMENTAL

Test condition of all ratings 77°F  
 Operating Temperature: 32° to 158°F  
 Storage Temperature: -13° to 176°F

#### PHYSICAL

Dimensions (HxWxD): 3.75 x 3.93 x 1.19in  
 Color: White  
 Weight/ Shipping Weight: <10 oz/ <1lb

### ORDERING INFORMATION:

SKU	Description
SC-EMS-ARC-Lighting	SC-EMS-ARC-Lighting Switched Lighting Controller, 12V, 120 to 277VAC
SC-EMS-ARC-Load	SC-EMS-ARC-Load Switched Load Controller, 24VDC, 120 to 277VAC

### ONE-LINE DIAGRAM WEB-ARC-LIGHTING:

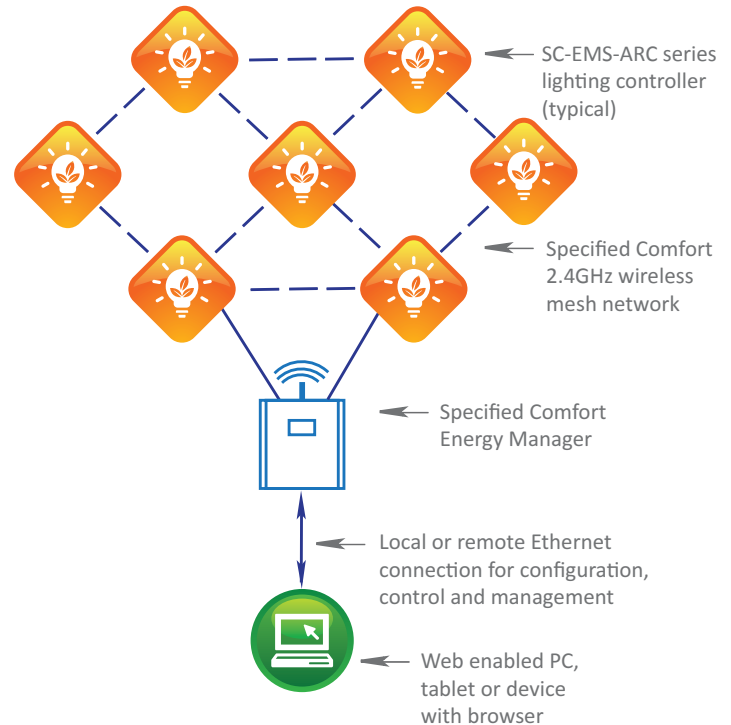

### ONE-LINE DIAGRAM WEB-ARC-LOAD:

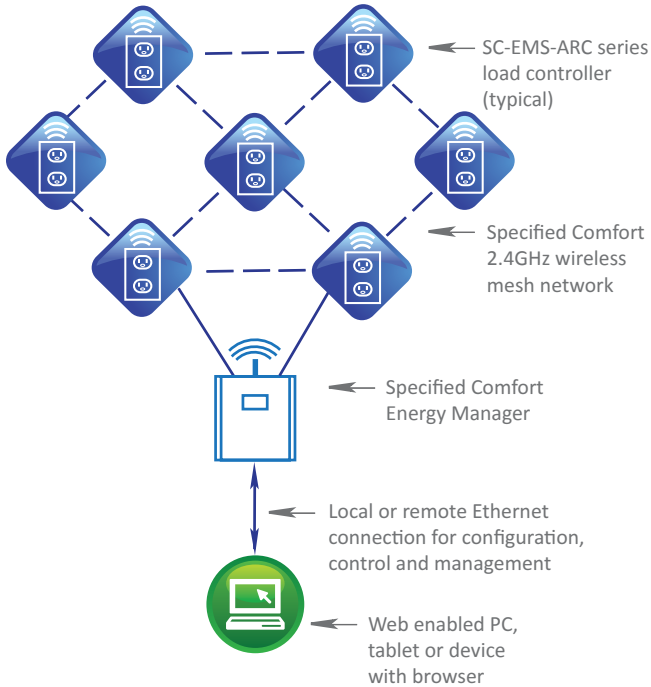

### DIMENSIONS:

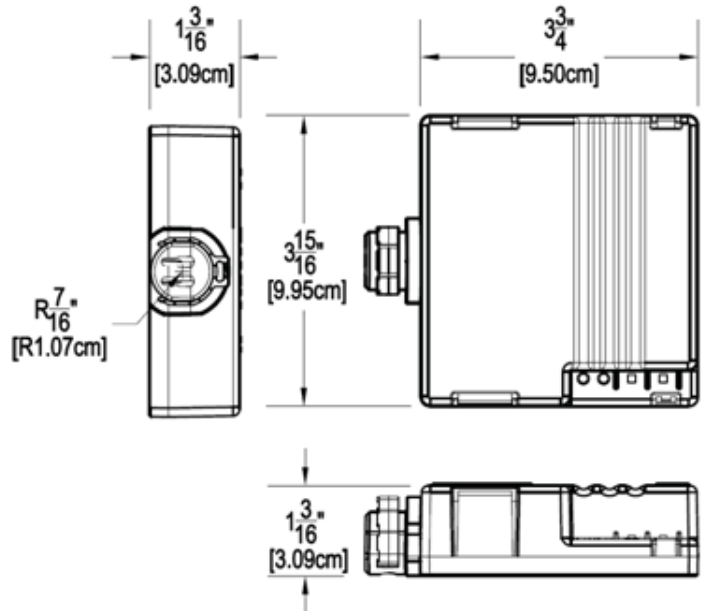

### The Specified Comfort Family

The Specified Comfort product line from Jackson Systems integrates lighting, climate control, fans, metering, and plug loads to provide a powerful integrated energy management solution. The lighting, thermostat, fan control and metering software share the Specified Comfort Manager and operate as an integrated application.

Specified Comfort software communicates via the Specified Comfort Manager to lighting controllers, motion sensors, thermostats, fans, meters and plugs using a secure wireless 2.4GHz ZigBee communications network.





### APPLICATIONS:

*Specified Comfort is suitable for renovation, upgrade and new construction projects.*

- Commercial Offices
- Educational Facilities
- Worship Facilities
- Research Facilities
- Retail Locations
- Hospitality & Restaurants

### FEATURES:

- Discreet, attractive, low-profile design
- High performance, compact contact closure sensor with wireless connectivity
- No control wiring required! Specified Comfort secure wireless 2.4GHz ZigBee communications with Specified Comfort Manager and other network devices
- Multiple sensors can be located in the same room to optimize HVAC, lighting, load and plug load control
- Low voltage, line powered device requires no batteries
- Two channels of momentary or maintained dry contact input
- Quick and easy to install
- Specified Comfort products operate independently or as an integrated solution
- FCC Certified
- Made in the USA (ARRA Compliant)



### DIMENSIONS:

The Specified Comfort Contact Sensor is an easy to install, compact, high performance dry contact sensor with an integrated wireless transceiver that uses the Specified Comfort wireless mesh network to connect to a Specified Comfort Manager and other Specified Comfort devices.

The low voltage Contact Sensor provides two channels of contact input used to detect the open-and-closed status of a pair of isolated contacts, such as a relay or switch. Wire leads can be connected to contacts and switches to sense momentary or maintained position.

Contact detected by the Contact Sensor is used by Specified Comfort's powerful family of Integrated Energy Management software applications and hardware to trigger changes in HVAC, lighting, load and plug load.

**SPECIFICATIONS:**

**ELECTRICAL**

Input Voltage: 12 to 24VDC, 24VAC  
 Input Current: 100mA max.

**I/O PORTS**

Channel 1: Dry contact, momentary or maintained  
 Channel 2: Dry contact, momentary or maintained

**RADIO NETWORK**

IEEE 802.15.4-2003 2.4GHz ISM (ZigBee)  
 Range: Approx. 1000' LOS transmit/ receive

**REGULATORY APPROVALS**

FCC (V8NZRB1000141)  
 IC (7737A-ZRB1000141)

**ENVIRONMENTAL**

Test condition of all ratings 77°F  
 Operating Temperature: 32° to 158°F  
 Storage Temperature: -13° to 176°F

**PHYSICAL**

Dimensions (HxWxD): 3.35 x 1.07 x 0.71in  
 Color: White  
 Weight/ Shipping Weight: <10 oz/ <1lb

**ORDERING INFORMATION:**

SKU	Description
SC-EMS-CS	Specified Comfort Contact Sensor

**DIMENSIONS:**

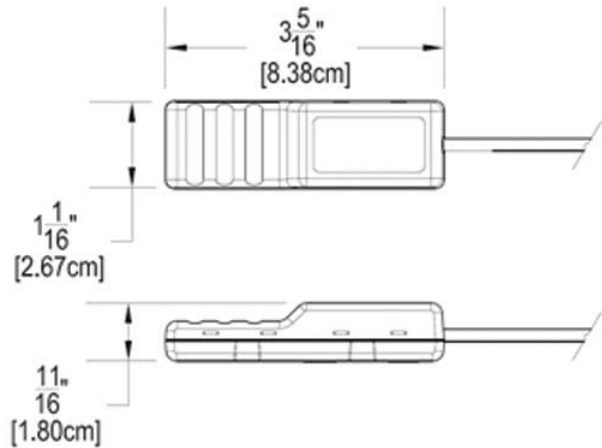

#### APPLICATIONS:

*Specified Comfort is suitable for renovation, upgrade and new construction projects.*

- Commercial Offices
- Educational Facilities
- Worship Facilities
- Research Facilities
- Retail Locations
- Hospitality & Restaurants

#### FEATURES:

- Compact solution for monitoring energy consumption per panel, circuit or feed for a facility or campus
- Easy to install NEMA 4x weather-proof surface mount enclosure
- Compatible with voltages from 120-480VAC, 50-60Hz
- Available Current Transformers (CTs) from 50A to 3,000A
- Revenue grade cost allocation with ANSI C12.1 Class 1 (optional Class 0.5 ANSI C12.20)
- Specified Comfort secure wireless 2.4GHz ZigBee communications with other network devices
- Easy way to add metering & verification to Specified Comfort thermostat and lighting systems
- The SC-EMS-DTS SMX Meter is an independent system that also integrates with other members of the Specified Comfort family
- Assembled with UL and CE Listed components
- Made in the USA (ARRA Compliant)



#### DESCRIPTION:

The SC-EMS-DTS SMX Meter is a power monitoring device featuring revenue grade measurement and wireless communication. The meter is for use with the Specified Comfort metering measurement and verification software and can add real-time energy monitoring to a Specified Comfort Integrated Energy Management solution that includes lighting and HVAC.

The SC-EMS-DTS SMX is compatible with voltage ranges from 120-480VAC and features load sensing from 50A to 3,000A. The meter is provided as a self-contained unit in a NEMA 4x enclosure with locking door. Featuring accurate revenue grade measurement, the SC-EMS-DTS SMX is used in conjunction with metering software to measure and track energy use for a specific area, load type or building.

Communication with other Specified Comfort Meters, the Specified Comfort Manager running metering software and other Specified Comfort devices (such as lighting and HVAC controls) is via a reliable wireless mesh network.

**SPECIFICATIONS:**

**GENERAL**

Voltage range: 120-480VACL-L, 3 or 4 W  
Rated voltage: 280 VACL-N / 485 VACL-L  
Voltage overload: 1.2 x  
Voltage burden: <0.1VA @ 280VACL-N  
Frequency: 45 to 65Hz  
Rated current: 1A to 5A isolated. 333mV or 5A or model dependent  
Power overload: 1.2 x

**ACCURACY**

Voltage: 0.5% < 0.2% typical (80-120%)  
Current: 0.5% < 0.2% typical (10•120%)  
Power: 0.5% < 0.2% typical (10-120%)  
Power Factor: 0.5% (between 0.5 and 1.0)  
Energy: Class 0.5 (ANSI C12.20)

**VOLTAGE SUPPLY**

Voltage: Powered from Phase A & B or Phase A & Neutral (model dependent)  
Frequency: 50/60Hz  
Burden: <5VA

**ENVIRONMENTAL**

Operating temp: 2° to 131°F  
Tolerance: -10%, +10%  
Storage temp: -40° to 185°F  
Humidity: 5 to 95% R.H. non-condensing

**MECHANICAL**

Case Material: Polycarbonate, Nema 4x  
Dimensions (HxDxW): 11.45 x 4.92 x 8.98in (291 x 125 x 228mm)  
Weight: 3.75lbs (1.7kg)

**RADIO NETWORK**

IEEE 802.15.4-2003 2.4GHz ISM (ZigBee)

**RADIO MODULE**

FCC ID: V8NZRB1000141  
IC: 7737A-ZRB1000141

Range: Approx. 1000' LOS transmit/receive

**STANDARDS & SAFETY**

Safety: IEC 61010 Pending  
EMC: IEC 61000-6-3 Emissions, IEC 61000-6-2 Immunity, IEC 61000-4-2, IEC 61000-4-3, IEC 61000-4-4, IEC 61000-4-5, IEC 61000-4-6, IEC 61000-4-8, IEC61000-4-11  
FCC: CISPR 22/ FCC 15 class A  
Other: IEC60688, Category III - 280VAC / 485VAC

**MEASUREMENT PARAMETERS:**

All Measurement Parameters are for L1,L2,L3, III

**MEASUREMENT TOPOLOGIES**

3-Phase, 3 and 4-wire  
Single Phase 2 and 3-wire (120/208 & 120/240V)

**MEASUREMENTS**

AC Volts (phase-phase)  
AC Volts (phase-neutral)

AC Current  
Frequency (Hz)

**POWER**

Active Power – kW  
Reactive Power – kVAr (inductive/ capacitive)  
Apparent Power – kVA  
Power Factor  
Phase Angle

**DEMAND**

kW – Sliding Window

**ENERGY**

Active Energy – kWh  
Reactive Energy – kVArh (inductive/capacitive)

**DIMENSIONS:**

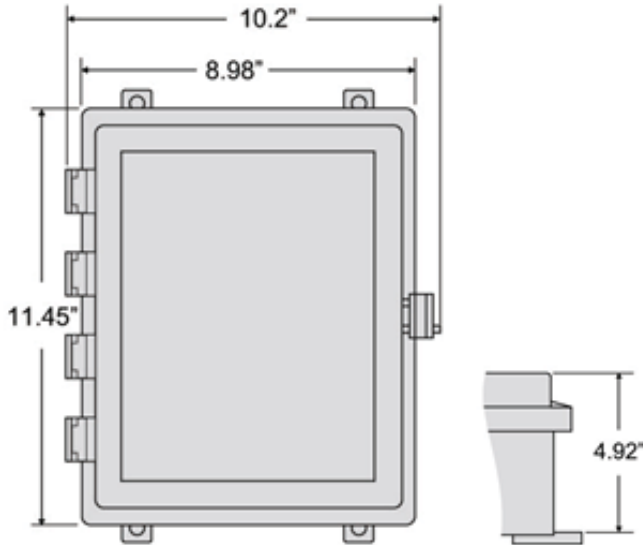

**ONE-LINE DIAGRAM:**

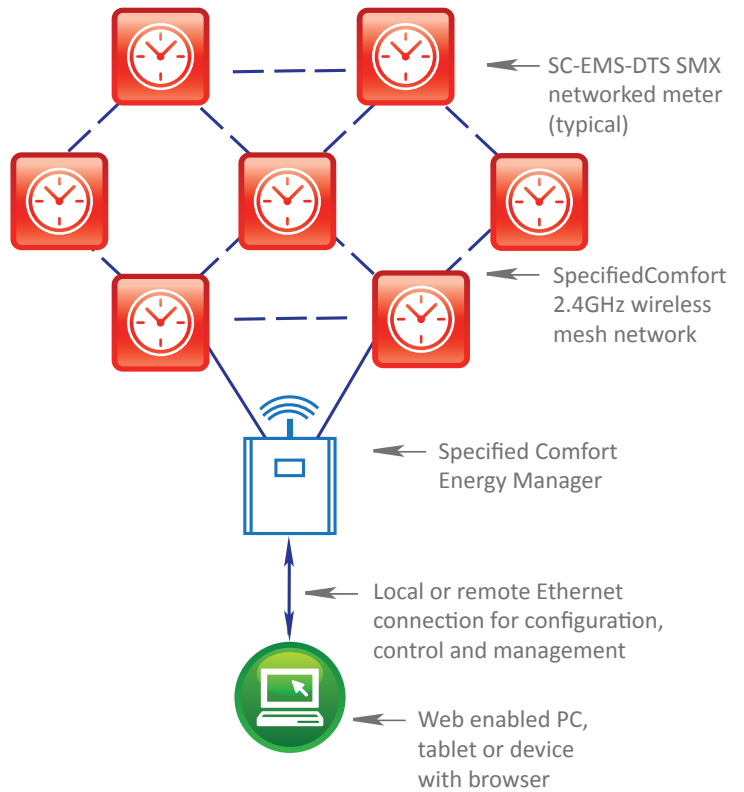

**THE SPECIFIED COMFORT FAMILY**

The Specified Comfort product line from Jackson Systems integrates lighting, climate control, fans, metering, and plug loads to provide a powerful integrated energy management solution. The lighting, thermostat, fan control and metering software share the Specified Comfort Energy Manager and operate as an integrated application.

Specified Comfort software communicates via the Specified Comfort Energy Manager to lighting controllers, motion sensors, thermostats, fans, meters and plugs using a secure wireless 2.4GHz ZigBee communications network.

**ORDERING INFORMATION:**

SKU	DESCRIPTION
SC-EMS-DTS-SMX	SC-EMS-DTS SMX-34-SM-N-N Packaged Meter
Requires (1) CT per phase (see "Optional Accessories"). Additional options are available.	

**Accessories: Split Core CT**

SKU	DESCRIPTION
SC-EMS-SCT750-50	MLG-SCT-0750-50A : 333mV
SC-EMS-SCT750-100	MLG-SCT-0750-100A : 333mV
SC-EMS-SCT750-200	MLG-SCT-0750-200A : 333mV
SC-EMS-SCT1250-100	MLG-SCT-1250-100A : 333mV
SC-EMS-SCT1250-200	MLG-SCT-1250-200A : 333mV
SC-EMS-SCT1250-400	MLG-SCT-1250-400A : 333mV
SC-EMS-SCT2000-600	MLG-SCT-2000-600A : 333mV
SC-EMS-SCT2000-800	MLG-SCT-2000-800A : 333mV
SC-EMS-SCT2000-1000	MLG-SCT-2000-1000A : 333mV
SC-EMS-SCT3000-2000	MLG-SCT-3000-2000A : 333mV
SC-EMS-SCT3000-3000	MLG-SCT-3000-3000A : 333mV



**Split Core CT**

The SC-EMS-SCT series of split core current transformers are designed for easy, non-intrusive installation in existing or new electrical networks around cables or busbar.

**APPLICATIONS:**

*Specified Comfort is suitable for renovation, upgrade and new construction projects.*

- Commercial Offices
- Educational Facilities
- Worship Facilities
- Research Facilities
- Retail Locations
- Hospitality & Restaurants

**FEATURES:**

- Discreet, attractive, low-profile design
- High performance, compact contact sensor with wireless connectivity for attachment to doors, windows, etc.
- No control wiring required! Specified Comfort secure wireless 2.4GHz ZigBee communications with Specified Comfort Manager and other network devices
- Multiple sensors can be located in the same room to optimize HVAC control
- Long battery life—up to 2 year battery life with standard AA batteries
- Low battery detection, with optional email alert when used with Specified Comfort software
- Quick and easy to install
- FCC Certified
- Made in the USA (ARRA Compliant)



**DESCRIPTION:**

The Specified Comfort Wireless Door/Window Sensor is an easy to install, compact, high performance door and window contact sensor with an integrated wireless transceiver that uses a wireless mesh network to connect to the Specified Comfort Energy Manager and other Web Comfort devices.

The Specified Comfort Wireless Door/Window Sensor quickly mounts to doors and windows. As a door or window is opened, the contact sensor detects changes in proximity to the remote magnetic sensor and will automatically set back HVAC using user-defined rules. When the contact sensor detects that doors and windows are closed, HVAC will resume with the previously set schedule.

Contact detected by the Specified Comfort Wireless Door/Window Sensor is used by Specified Controls powerful Specified Comfort family of Integrated Energy Management software applications and hardware to trigger changes in HVAC, lighting, load and plug load.

## SPECIFICATIONS:

### ELECTRICAL

Input Voltage: 2 AA batteries

### ENVIRONMENTAL

Operating Temperature: 32° to 158°F

Storage Temperature: -13° to 176°C

### DETECTION RANGE

Up to 1 inch separation

### RADIO NETWORK

IEEE 802.15.4-2003 2.4GHz ISM (ZigBee)

Range: Approx. 100' LOS transmit/ receive from any line powered autaniNet device

### REGULATORY APPROVALS

FCC (V8NWAT1000119)

IC (7737A-WAT1000119)

### PHYSICAL

Dimensions (HxWxD): 3.01 x 1.19 x 1.56in

Color: White

Weight/ Shipping Weight: <10 oz/ <1lb

## ORDERING INFORMATION:

SKU	Description
WEB-DWCS	Web Comfort Wireless Door/Window Contact Sensor (Includes magnetic contact)

## ONE-LINE DIAGRAM:



## DIMENSIONS:

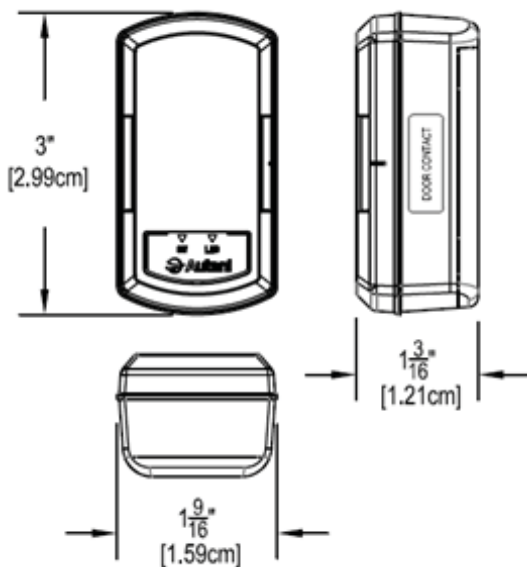



#### APPLICATIONS:

*Airius Air Pear Fans are a managed system of thermal destratification fans that reduce energy consumption by increasing the efficiency of heating and cooling systems.*

- Warehouse & Industrial Facilities
- Grocery & Retail Stores
- Gymnasiums & Auditoriums
- Hospitality

#### FEATURES:

- Destratification and Thermal Equalization can reduce energy consumption up to 30% or more
- Suitable for mounting height from 25' – 100' and up to 2500 ft<sup>2</sup> of coverage per unit (see model numbers for specific coverage)
- A properly applied array of units is capable of achieving temperature balance within 0° to 3°F
- Control and monitoring of speed, direction, and run time via Specified Comfort software
- Specified Comfort secure wireless 2.4GHz ZigBee communications with network devices
- Real-time alerting for user defined and system events via email or smart phone
- Easy installation for connection to building structure; drop ceiling mounting kit available
- Meets LEED EA Credit, "Optimize Energy Performance"
- Manufactured from recyclable materials and shipped in recyclable corrugated packaging
- Made in the USA (ARRA Compliant)



#### DESCRIPTION:

The SC-EMS-FAN Airius Air Pear fan is a wirelessly managed destratification fan. These fans form the foundation of Specified Comfort Thermal Equalizer System that reduces energy consumption by increasing the efficiency of heating and cooling systems.

Stratification, or temperature layering, occurs when there is minimal air movement within an enclosed building space. Heat (naturally or artificially generated) rises to the ceiling while cold air sinks to the floor. Temperatures can increase up to 1°F per foot of building elevation.

In cold weather, destratification redirects hot air from the ceiling to the floor, recycling existing heat and reducing energy consumption. In moderate or warm weather, destratification reduces temperature differentials within the space and increases the efficiency of HVAC systems.

As a network device, the SC-EMS-FAN Airius Air Pear is controlled by Specified Comfort software. This software manages the speed, direction and run-time of destratification fans based upon schedules and demand response requests.

### SPECIFICATIONS:

#### MOTOR

115V or 230/277V, 0 - 79 dB(A)  
 Watts: 0-170 @ 115V / 0-175 @ 230/277V  
 RPM: 0-2850 @ 115V / 0-3050 @ 230/277V  
 CFM: 0-1180 @ 115V / 0-1290 @ 230/277V  
 (m3/hr): 0-2004 @ 115V / 0-2191 @ 230/277V  
 AMPS: 0-2.2 @ 115V / 0-1.4 @ 230/277V

No lubrication required; bearings are sealed

#### HOUSING

Weight: 14lbs (6.4kgs)  
 Height to Rim: 18in (457mm)  
 Total Height: 24in (610mm)  
 Diameter: 15in (380mm)

#### COVERAGE

Up to 1500ft<sup>2</sup> or a 44ft coverage diameter with a mounting height up to 45ft

#### RADIO NETWORK

IEEE 802.15.4-2003 2.4GHz ISM (ZigBee)  
 Range: Approx. 1000' LOS transmit/ receive

#### REGULATORY APPROVALS

UL Standard 507 for Safety Electric Fans  
 ETL certified fan and components  
 5VA flame resistance rating  
 RoHS compliant

#### LIMITATIONS

Mounting height up to 45ft  
 Do not install in environments open to the elements

#### GENERAL

Color(s): Gray, Cool Gray  
 Outer shell and stator: Fire rated 5VA materials  
 Power cord: 3 wire 18 AWG (or 16 AWG) 300VAC rated electrical cord (UL rated as SJT)  
 115VAC version comes with molded 3-prong plug  
 230/277VAC versions do not have a plug supplied  
 Warranty: 3-years from shipping date

#### SAFETY PRECAUTIONS PROVIDED

Seismic restraint point for earthquake codes  
 Thermal overload protection

### ORDERING INFORMATION:

SKU	Description
SC-EMS-FAN45 Wireless	Model 45 – 115V-EL-LISA with Specified Comfort wireless control For ceiling height 25' – 45'; 1500ft <sup>2</sup> area
SC-EMS-FAN60 Wireless	Model 60 – 115V-EL-LISA with Specified Comfort wireless control For ceiling height 25' – 60'; 2000ft <sup>2</sup> area
SC-EMS-FAN100 Wireless	Model 100 – 200/277V-EL-LISA with Specified Comfort wireless control For ceiling height 25' – 100'; 2500ft <sup>2</sup> area

*Also available with wired controls and 230V.*

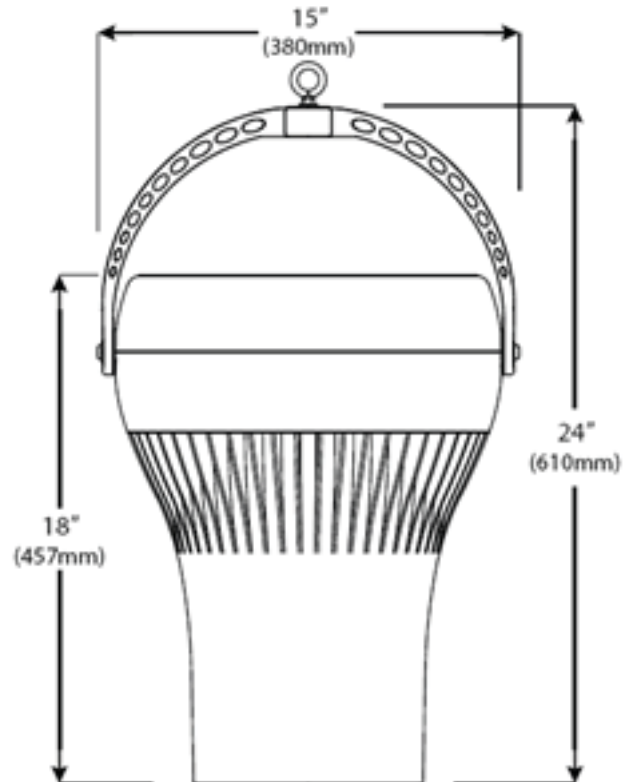

#### APPLICATIONS:

*Specified Comfort Wired Motion Sensor is suitable for renovation, upgrade and new construction projects.*

- Commercial Offices
- Educational Facilities
- Worship Facilities
- Research Facilities
- Retail Locations
- Hospitality & Restaurants

#### FEATURES:

- Discreet, attractive, low-profile design
- High performance, compact passive infrared motion sensor compatible with the Specified Comfort ARC series of Room Controllers
- Includes mounting hardware for walls, ceilings and standard T-Bar ceiling grids
- Standard, Slight, Spot and 10m detection patterns available
- Multiple sensors can be connected in parallel to increase coverage area or to accommodate special room shapes
- Connects to SC-EMS-ARC series room controllers using standard RJ-11 connectors and cabling (modular telephone wiring)
- Quad type pyroelectric element provides precise detection, even of small movements
- The SC-EMS-OS wired motion sensor is an independent system that also integrates with other members of the Specified Comfort family
- Made in the USA (ARRA Compliant)



#### DESCRIPTION:

The Specified Comfort SC-EMS-OS Wired Sensor is an easy to install, compact, high performance motion sensor that connects directly to the Specified Comfort SC-EMS-ARC series of room controllers. The SC-EMS-OS detects changes in infrared radiation that occur when there is movement by a person (or object) which is different in temperature from the surroundings.

Specified Comfort SC-EMS-OS Motion Sensors are available with Standard, Slight, Spot and 10m detection patterns. Multiple SC-EMS-OS Sensors may be connected in parallel to a single SC-EMS-ARC for increased coverage in larger rooms. The SC-EMS-OS quickly mounts to a wall or ceiling using the included hardware kit and connects to the Specified Comfort SC-EMS-ARC range of room controllers using

Motion detected by the SC-EMS-OS is used by Specified Controls powerful Specified Comfort family of Integrated Energy Management software applications and hardware to trigger changes in lighting, load, plug load and HVAC systems.

**SPECIFICATIONS:**

**ELECTRICAL**

Input Voltage Range: 2.2 to 3.0VDC

**ENVIRONMENTAL**

Operating Temperature: 32° to 158°F

Storage Temperature: -13° to 176°F

**DETECTION RANGE**

10m Detection: 110° x 93°, 10m (32.808ft) max.

Slight Detection: 91° x 91°, 2m (6.562ft) max.

Spot Detection: 38° x 22°, 5m (16.404ft) max.

5m Detection: 100° x 82°, 5m (16.404ft) max.

**DETECTION CONDITIONS**

Detectable temperature difference between target and background is more than 39°F.

Movement Speed/ 10m: 0.5 to 1.5 m/s

Movement Speed/ Slight: 0.5 m/s

Movement Speed/ Spot: 0.8 to 1.2 m/s

Movement Speed/ 5m: 0.8 to 1.2 m/s

**CONNECTION**

6' Plenum Rated cable with installed RJ-11, modular connector

**PHYSICAL**

Dimensions (HxWxD): 3.12 x 2.18 x 2.11in

Color: White

Weight/ Shipping Weight: <10 oz/ <1lb

**ORDERING INFORMATION:**

SKU	Description
	Includes 6' Plenum Rated cable with RJ-11 modular connector, Motion Sensor Pivot Arm, and clip mount for standard T-Bar grid. Sensor Mounting Bracket for non T-Bar ceilings sold separately.
SC-EMS-OS WIRED	Wired Motion Sensor

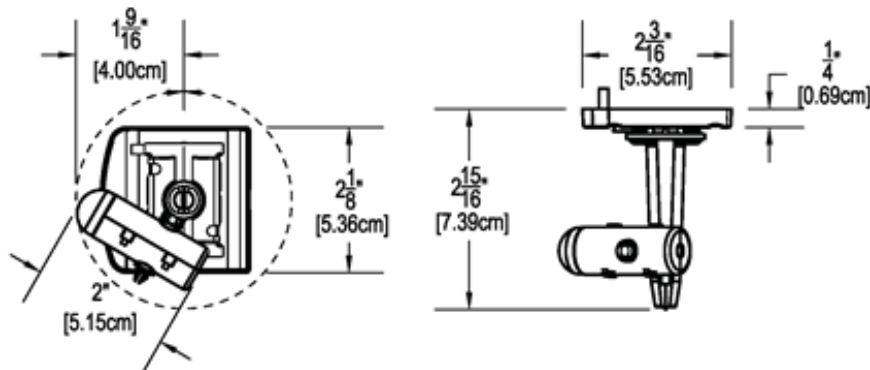

#### APPLICATIONS:

*Specified Comfort Wired Motion Sensor is suitable for renovation, upgrade and new construction projects.*

- Commercial Offices
- Educational Facilities
- Worship Facilities
- Research Facilities
- Retail Locations
- Hospitality & Restaurants

#### FEATURES:

- Discreet, attractive, low-profile design
- High performance, compact passive infrared motion sensor with wireless connectivity
- No control wiring required! Specified Comfort secure wireless 2.4GHz ZigBee communications with the Specified Comfort Manager and other network devices
- Standard, Slight, Spot and 10m detection patterns available
- Multiple sensors can be located in the same room to increase coverage area or to accommodate special room shapes
- Includes multi-position mounting bracket for wall or ceiling installation
- Quad type pyroelectric element provides precise detection, even of small movements
- Specified Comfort is an independent system that also integrates with other members of the Specified Comfort family
- Quick and easy to install
- Made in the USA (ARRA Compliant)



#### DESCRIPTION:

The Specified Comfort SC-EMS-OSB Wireless Motion Sensor is an easy to install, compact, high-performance motion sensor with integrated wireless transceiver that uses the Specified Comfort wireless mesh network to connect to the Specified Comfort Energy Manager.

The SC-EMS-OSB detects changes in infrared radiation that occur when there is movement by a person (or object) which is different in temperature from the surroundings.

The Specified Comfort SC-EMS-OSB Wireless Motion Sensors are available with Standard, Slight, Spot and 10m detection patterns. The SC-EMS-OSB quickly mounts to a wall or ceiling using included hardware kit.

Motion detected by the SC-EMS-OSB Wireless Motion Sensor is used by the powerful Specified Comfort family of Integrated Energy Management software applications and hardware to trigger changes in lighting, load, plug load and HVAC systems.

### SPECIFICATIONS:

#### ELECTRICAL

Input Voltage: 2 AA batteries

#### ENVIRONMENTAL

Operating Temperature: 32° to 158°F

Storage Temperature: -13° to 176°F

#### DETECTION RANGE

10m Detection: 110° x 93°, 10m (32.808ft) max.

Slight Detection: 91° x 91°, 2m (6.562ft) max.

Spot Detection: 38° x 22°, 5m (16.404ft) max.

5m Detection: 100° x 82°, 5m (16.404ft) max.

#### DETECTION CONDITIONS

Detectable temperature difference between target and background is more than 39°F.

Movement Speed/ 10m: 0.5 to 1.5 m/s

Movement Speed/ Slight: 0.5 m/s

Movement Speed/ Spot: 0.8 to 1.2 m/s

Movement Speed/ 5m: 0.8 to 1.2 m/s

#### RADIO NETWORK

IEEE 802.15.4-2003 2.4GHz ISM (ZigBee)

Range: Approx. 100' LOS transmit/ receive from any line powered Specified Comfort device

#### REGULATORY APPROVALS

FCC (V8NWAT1000119)

IC (7737A-WAT1000119)

#### PHYSICAL

*Dimensions without mounting hardware*

Dimensions (HxWxD): 3.01 x 1.7 x 2.14in

Color: White

Weight/ Shipping Weight: <10 oz/ <1lb

### ORDERING INFORMATION:

SKU	Description
	Wall mount sleeve is included. Requires (2) AA batteries (not included).
SC-EMS-OSB	Battery-Powered Wireless Motion Sensor

### DIMENSIONS:

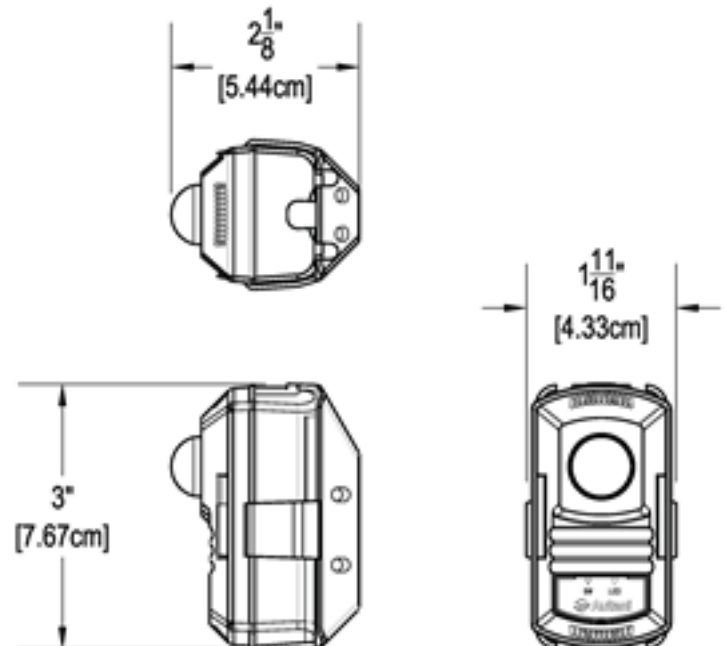

#### APPLICATIONS:

*The Specified Comfort SmartLet Outlet Controller provides automatic receptacle control as required by ASHRAE 90.1 2010 Section 8.4.2.*

- Private Offices
- Open Offices
- Computer Classrooms
- Hospitality & Retail

#### FEATURES:

- Easy-to-install automatic receptacle control for 15A/120VAC outlets suitable for new construction and upgrade projects
- Integrated, mechanically switched relay controls one or both receptacles by any combination of schedule, occupancy/ vacancy, demand response, and activity of plug loads
- Occupancy sensors and scheduling are shared with ARC and AFC series lighting controllers
- Local over-ride to manually switch receptacles ON or OFF with LED status indicators
- On-board energy monitoring to measure and track power consumption of plug loads in real time
- Fail safe operation maintains local control of receptacles at all times
- Specified Comfort secure wireless 2.4GHz ZigBee communications with other network devices
- FCC and IC certified; UL Pending
- Made in the USA (ARRA Compliant)



#### DESCRIPTION:

The Specified Comfort Smartlet integrates automatic receptacle control with dimming and switching systems. The Outlet Controller switches 120VAC receptacles ON or OFF based upon occupancy, schedules, and demand response events. The Specified Comfort Smartlet is attached to 15A/120VAC duplex receptacles, which power the device.

The Specified Comfort SmartLet Outlet Controller is wirelessly configured, scheduled, and controlled by a Specified Comfort Energy Manager. Dynamic scheduling allows the user to define ON and OFF events for receptacles, as well as periods governed by occupancy rules. Timeouts to switch off loads in unoccupied spaces are easily set per schedule or event, and can vary throughout the day.

Connectivity between the SmartLet, Specified Comfort Energy Manager, and other devices is via the secure, reliable Specified Comfort wireless mesh network.

**SPECIFICATIONS:**

**ELECTRICAL**

Load Capacity: 15A @ 120VAC

Input Voltage: 120VAC typ.

Max. Switching Power: 1800VA

**RADIO NETWORK**

IEEE 802.15.4-2003 2.4GHz ISM (ZigBee)

Range: Approx. 600' LOS transmit/receive

**REGULATORY APPROVALS**

UL Pending

Contains FCC Certified Module:

FCC ID: V8NWAT1000142

IC: 7737A-WAT1000142

**ENVIRONMENTAL**

Test condition of all ratings 77°F

Operating Temperature: 32° to 158°F

Storage Temperature: -13° to 176°F

**PHYSICAL**

Dimensions (HxWxD): 6.05 x 4.2 x 1.31in

Color: White

Weight: < 1lb

**ORDERING INFORMATION:**

SKU	Description
SC-EMS-SMARTLET	SmartLet Outlet Controller with (2) receptacles managed by (1) relay

**ONE LINE DIAGRAM:**

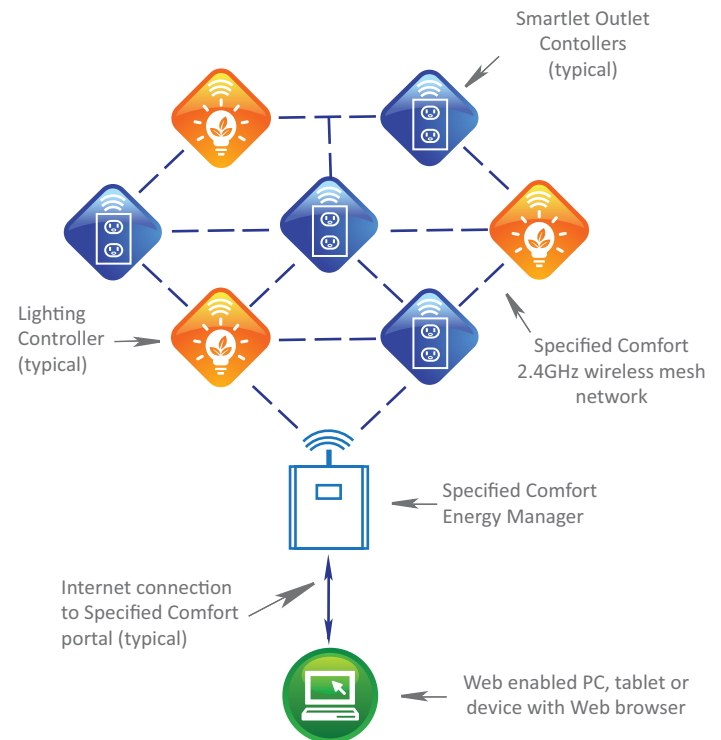

**THE SPECIFIED COMFORT FAMILY**

The Specified Comfort product line from Specified Controls integrates lighting, climate control, fans, metering and plug loads to provide a powerful integrated energy management solution. The lighting, thermostat, fan control and metering software share the Specified Comfort Energy Manager and operate as an integrated application.

Specified Comfort software communicates via the Specified Comfort Energy Manager to lighting controllers, motion sensors, thermostats, fans, meters and plugs using a secure wireless 2.4GHz ZigBee communications network.



### APPLICATIONS:

*Specified Comfort is suitable for renovation, upgrade and new construction projects.*

- Commercial Offices
- Educational Facilities
- Worship Facilities
- Research Facilities
- Retail Locations
- Hospitality & Restaurants

### FEATURES:

- Discreet, attractive, low-profile design
- High performance, compact normally open relay with wireless connectivity
- No control wiring required! Specified Comfort secure wireless 2.4GHz ZigBee communications with Specified Comfort Manager and other network devices
- Multiple sensors can be located in the same room to optimize HVAC, lighting, load and plug load control
- Low voltage, line powered device requires no batteries
- Quick and easy to install
- Specified Comfort products operate independently or as an integrated solution
- FCC Certified
- Made in the USA (ARRA Compliant)



### DESCRIPTION:

The Specified Comfort Relay is an easy to install, compact, high performance switching relay with an integrated wireless transceiver that uses the Specified Comfort wireless mesh network to connect to a Specified Comfort Energy Manager and other Specified Comfort devices.

The low voltage Relay provides a method to switch a 24VAC load on or off.

**SPECIFICATIONS:**

**ELECTRICAL**

Input Voltage: 12 to 24VDC, 24VAC

Relay Switching Current: 1 amp

Relay Switching Voltage: 24VAC

**I/O PORTS**

Normally open relay

**RADIO NETWORK**

IEEE 802.15.4-2003 2.4GHz ISM (ZigBee)

Range: Approx. 1000' LOS transmit/ receive

**REGULATORY APPROVALS**

FCC (V8NZRB1000141)

IC (7737A-ZRB1000141)

**ENVIRONMENTAL**

*Test condition of all ratings 77°F*

Operating Temperature: 32° to 158°F

Storage Temperature: -13° to 176°F

**PHYSICAL**

Dimensions (HxWxD): 3.35 x 1.07 x 0.71in

Color: White

Weight/ Shipping Weight: <10 oz/ <1lb

**ORDERING INFORMATION:**

SKU	Description
SC-EMS-Relay	Specified Comfort Relay

**DIMENSIONS:**

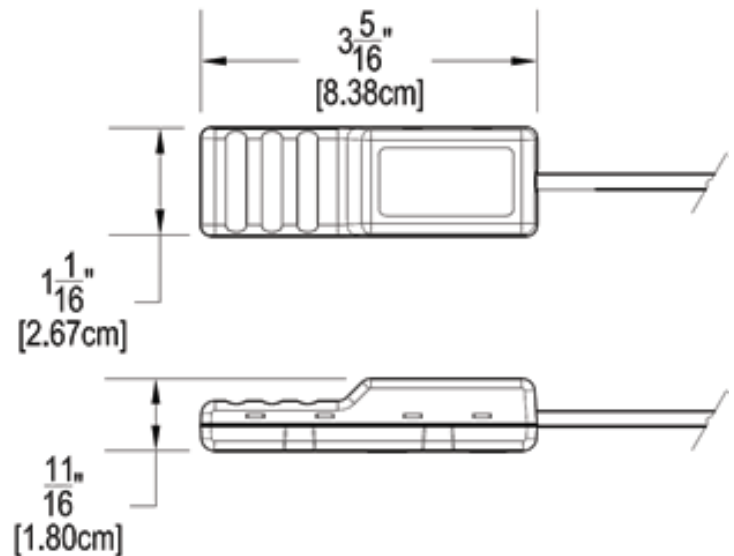

**WIRING:**

Black - 24VAC common

Red - 24VAC hot

Blue - Load normally open

Black - Load common