

KVE

Capture Jet® Hood with Side-Jet Technology

KVE/PC/xxxx11507/EN

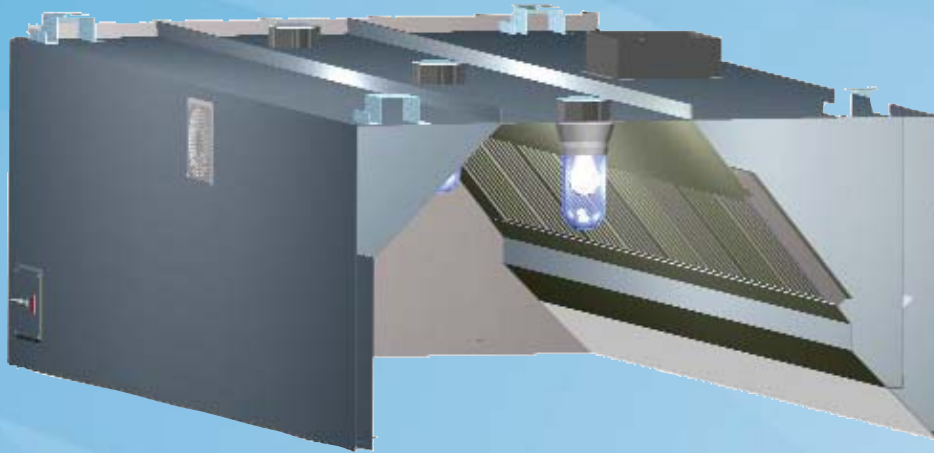

The KVE Capture Jet® hood with Side-Jet technology is a highly efficient kitchen ventilation hood that removes contaminated air and excess heat emitted by cooking equipment, helping to provide a comfortable and clean environment.

The KVE hood uses the advanced Halton Capture Jet® with Side-Jet technology to improve the capture and containment of the airflows generated by the cooking equipment. Overall exhaust airflow rates can be reduced up to 30% from those of traditional kitchen hoods.

The Capture Jet® hood with Side-Jet technology is based on the high entrainment efficiency of a compact, high-velocity capture air jet. The capture air jets efficiently induce ambient air at the critical front face area of the hood, minimizing the spillage of the contaminated air and maintaining good air quality in the chef's work area.

- Improved indoor air quality with reduced energy use. Halton Capture Jet® with Side-Jet technology reduces the exhaust airflow rates required and improves the capture and containment efficiency of the hood.
- High efficiency grease filtration using UL and NSF classified Halton KSA multi-cyclone filters for removal of up to 95% of particles with a size of 8 microns or above.
- Standard delivery includes lighting, T.A.B.™ testing and balancing tabs, which allow accurate and effective commissioning.
- Stainless steel, welded design.

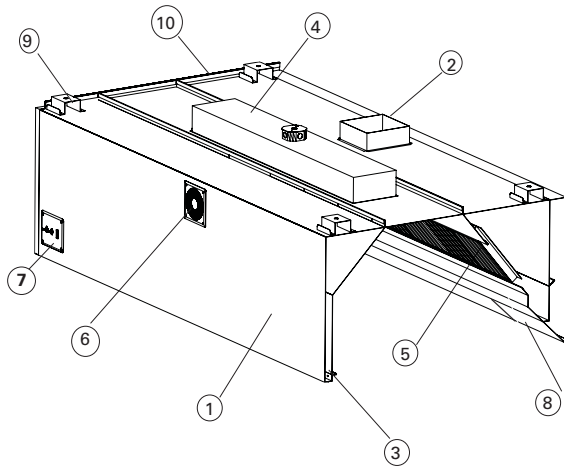

| Part | Description |
|------|-----------------------------------|
| 1 | 18 Ga. Stainless steel |
| 2 | Exhaust duct collar |
| 3 | Capture Jet air |
| 4 | Light fixture |
| 5 | KSA grease filters |
| 6 | Integrated Capture Jet fan intake |
| 7 | Switch panel (optional) |
| 8 | Grease collection cup |
| 9 | Hanger bracket |
| 10 | Double wall construction |

Construction

The KVE hood combines Capture Jet® with Side-Jet technology, light fixtures, airflow measurement T.A.B. ports and KSA grease filters. The hood shall bear ETL or UL label. The ETL/UL listed range hood without exhaust fire damper per standard 710 and be fabricated in compliance with NFPA-96, and shall bear the NSF seal of approval.

The exposed parts are manufactured from 18 ga. stainless steel.

The hood ends have double side wall construction. A concealed collection cup is fitted into the grease drain channel for easy removal of the grease and dirt extracted by the KSA multi-cyclone filters.

DIMENSIONS

| KVE | inches |
|--------|-----------|
| Length | 48....168 |
| Width | 42....84 |
| Height | 24....30 |

QUICK DATA

| Length | Recommended Exhaust air volumes | Recommended Capture Jet air volumes |
|-----------|--|---|
| 48....168 | * Actual exhaust air volumes are calculated by using the heat load based design method utilizing the Halton H.E.L.P. (Hood Engineering Layout Program) | Capture Jet average pressure 0.40" WC (without Side Jet option), 0.20" WC (with Side Jet option). |
| | *Average operating range from light to to heavy duty cooking loads 135 cfm to 275 cfm per linear foot | *Airflows established by a pressure reading *WC= Water Column |

*Hoods are ETL or UL listed for USA per UL710, and CANADA per ULC-S646 standards, and NSF certified.

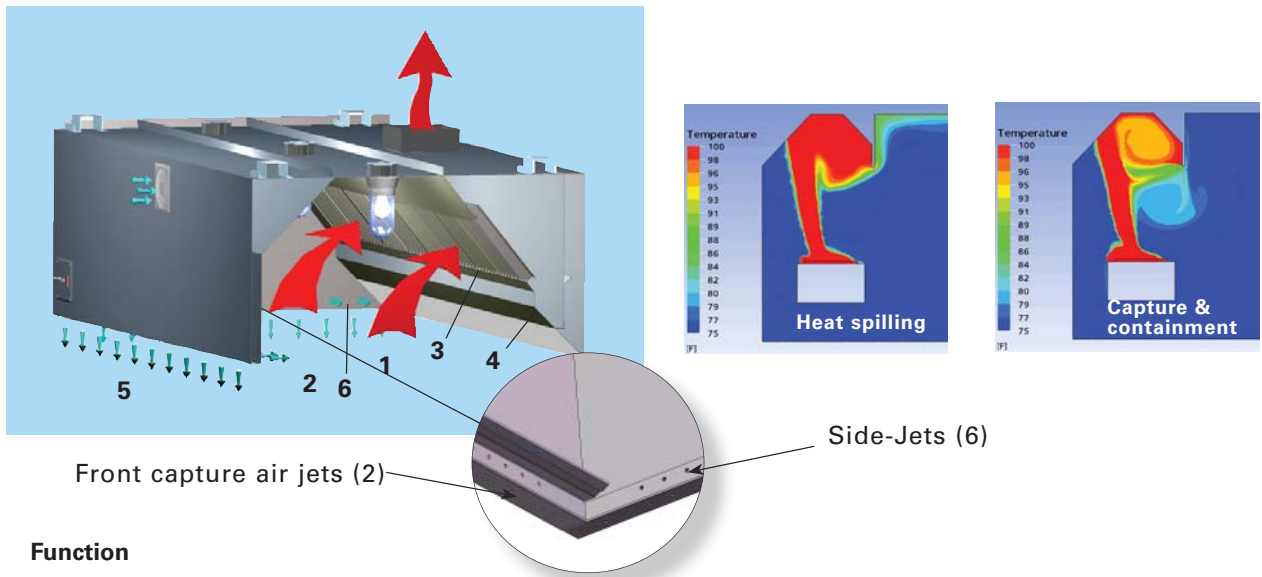

Function

The kitchen hood above cooking appliances contains the rising warm air and contaminants (1). The capture air jets (2) direct the contaminated air toward the KSA grease filters (3), where grease particles and other impurities are separated from the exhaust air using the cyclone separation principle.

The extracted grease and other air contaminants flow into a drain channel and toward the collection tray/cup (4). The vertical capture air improves efficiency, and allows the hood to operate at lower exhaust airflows. This is achieved by modifying the capture jet configuration on the front of the hood (5). The side jets allow for enhanced performance at the ends of the hood (6).

Accessories

- Closure Panels - for canopies below ceiling level
- Backsplash
- Side Skirts (optional)
- KFR - Filter Removal Tool
- Recessed fluorescent
- Recessed incandescent
- MEP - Master Electrical Panels
- Face or remote mounted switch panels
- Factory prepiped Fire Protection

DIMENSIONS

| KVE - Wall model | inches |
|------------------|-----------|
| Length | 48....168 |
| Width | 42....84 |
| Height | 24....30 |

Noted in drawings as:

- * L = Length
- * W = Width
- * H = Height

WEIGHTS (LB)

18 ga.

| Estimated Crated Shipping Weight | inches | Weight |
|----------------------------------|--------|--------------|
| Width | 48" | 75 lbs / ft. |
| Width | 54" | 80 lbs / ft. |
| Width | 60" | 85 lbs / ft. |

*Larger Weights - Consult Factory

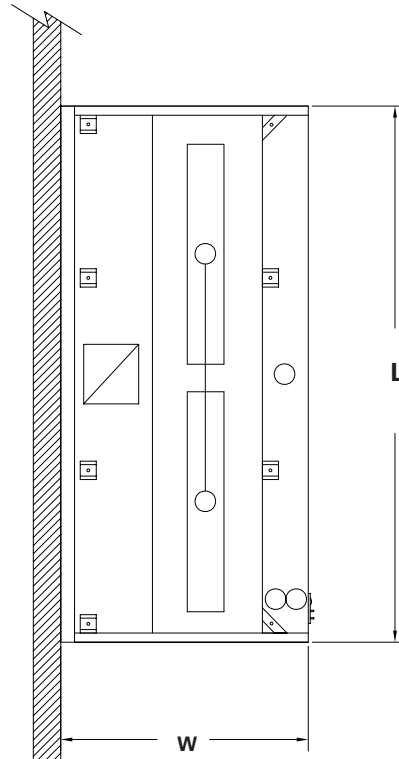
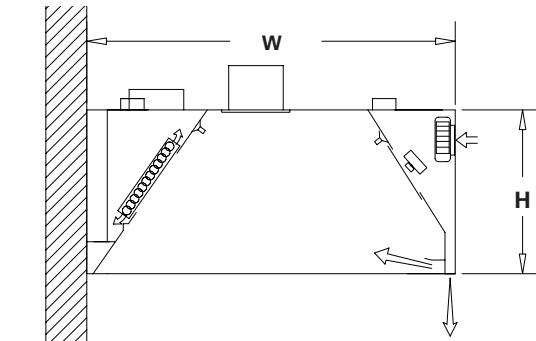

Mounting bracket 2" high (52mm)

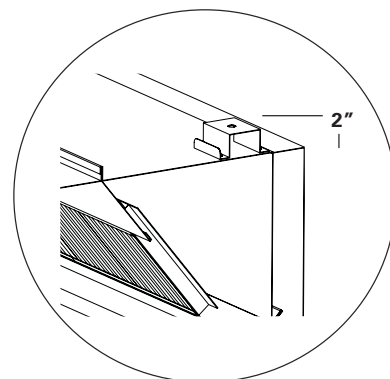

DIMENSIONS

| KVE - Island model | inches |
|--------------------|-----------|
| Length | 48....168 |
| Width | 42....84 |
| Height | 24....30 |
| Overall Width | 84....168 |

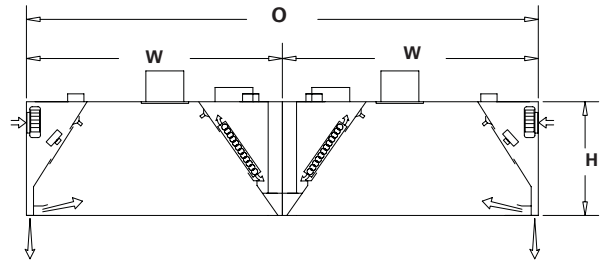

Noted in drawing as:

- * L = Length
- * W = Width
- * H = Height
- * O = Overall Width

WEIGHTS (LB)

18 ga.

| Estimated Crated Shipping Weight | inches | Weight |
|----------------------------------|--------|--------------------|
| Width | 48" | 75 lbs / lin. ft. |
| Width | 54" | 80 lbs / lin. ft. |
| Width | 60" | 85 lbs / lin. ft. |
| Width | 66" | 90 lbs / lin. ft. |
| Width | 72" | 95 lbs / lin. ft. |
| Width | 78" | 100 lbs / lin. ft. |

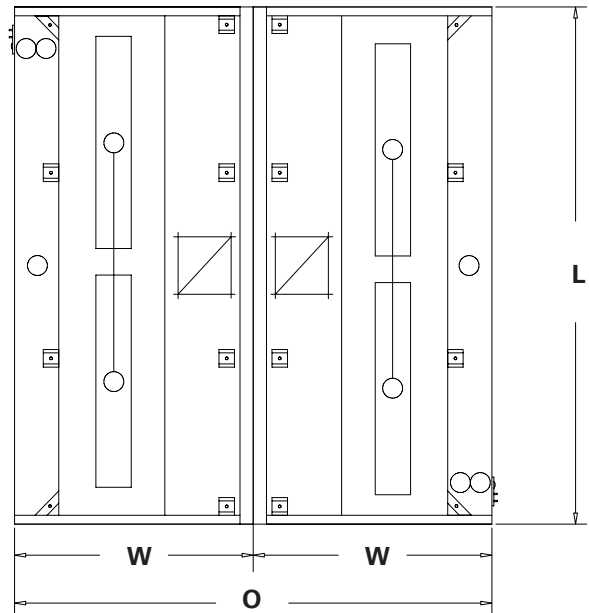

*Larger Weights - Consult Factory

Mounting bracket 2" high (52mm)

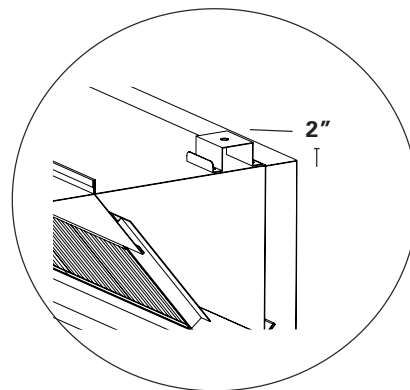

Balancing of Capture Jet™ canopies

The capture jet and exhaust air flows are easily and accurately determined by measuring the pressure difference from the T.A.B. ports mounted in each plenum. Corresponding air flows can be read from the diagrams provided.

All T.A.B. readings assume cold conditions. To adjust for an exhaust temperature of 110 °F, multiply the readings by a factor of 0.93.

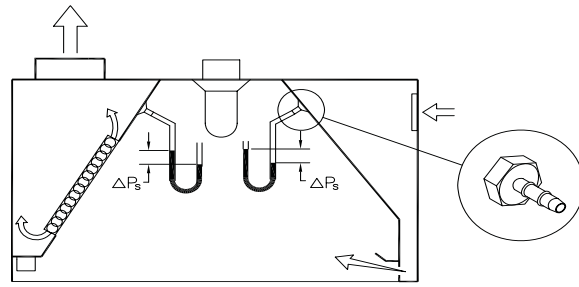

Exhaust air flow vs. pressure differential

KVE/KVC- (2 Filters)

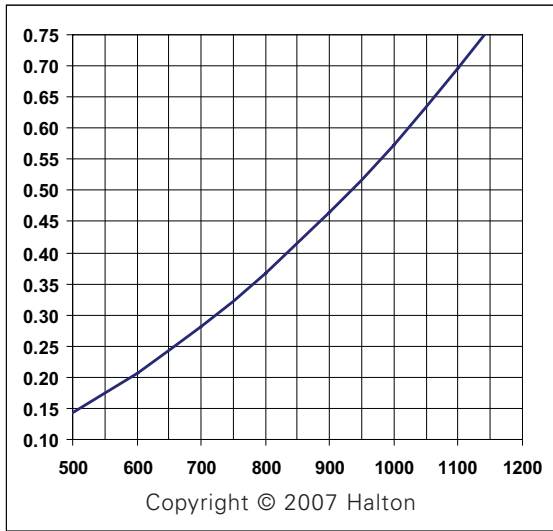

KVE/KVC- (3 Filters)

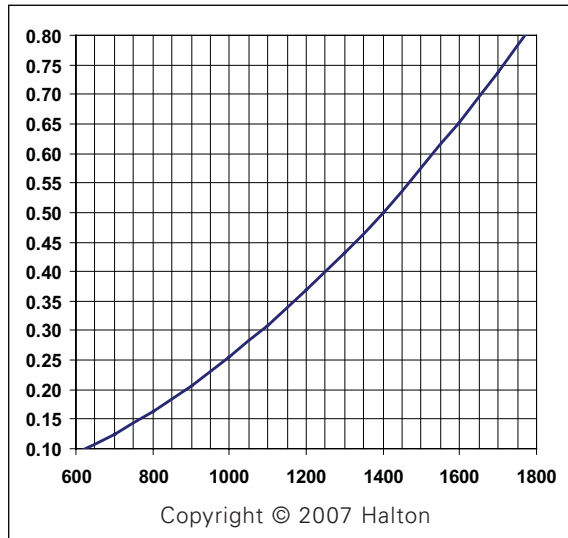

KVE/KVC- (4 Filters)

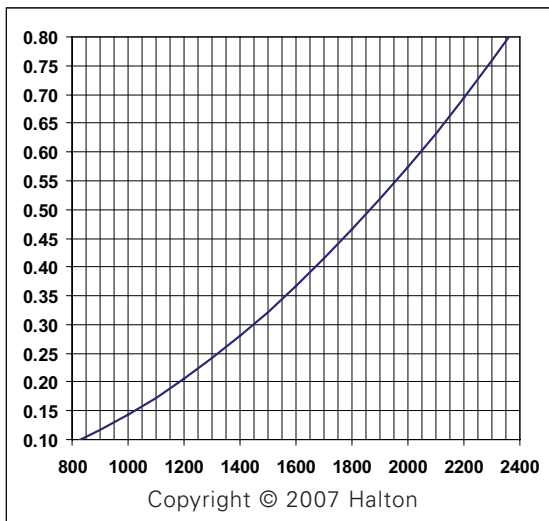

KVE/KVC- (5 Filters)

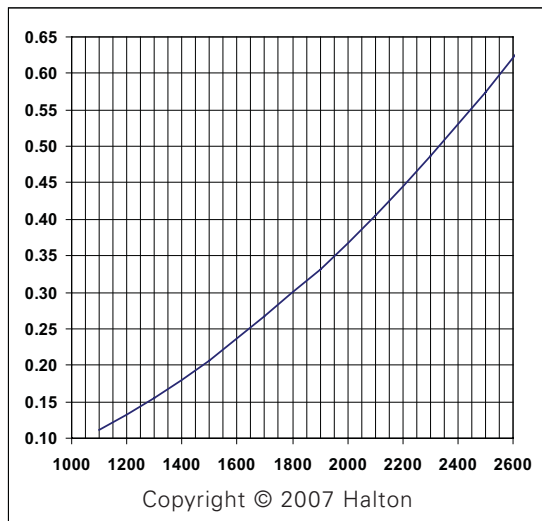

Balancing of Capture Jet® canopies

The capture jet and exhaust air flows are easily and accurately determined by measuring the pressure difference from the T.A.B. ports mounted in each plenum. Corresponding air flows can be read from the diagrams provided.

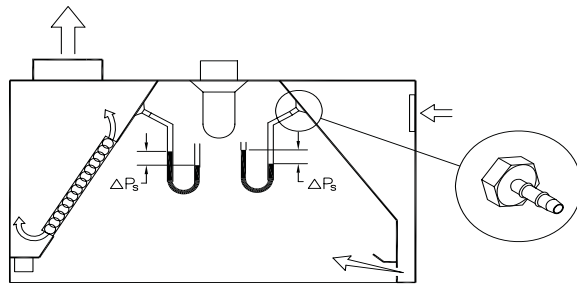

Exhaust air flow vs. pressure differential

All T.A.B. readings assume cold conditions. To adjust for an exhaust temperature of 110 °F, multiply the readings by a factor of 0.93.

KVE/KVC-(6 Filters)

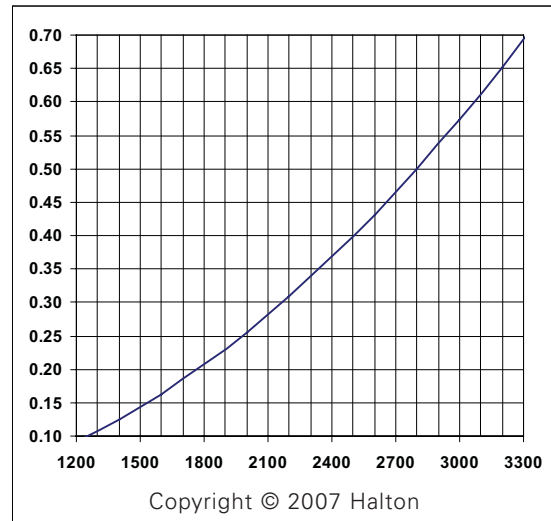

KVE/KVC-(7 Filters)

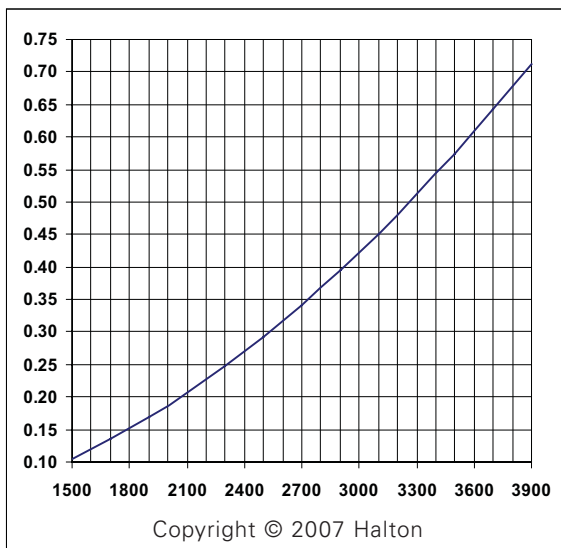

KVE/KVC-(8 Filters)

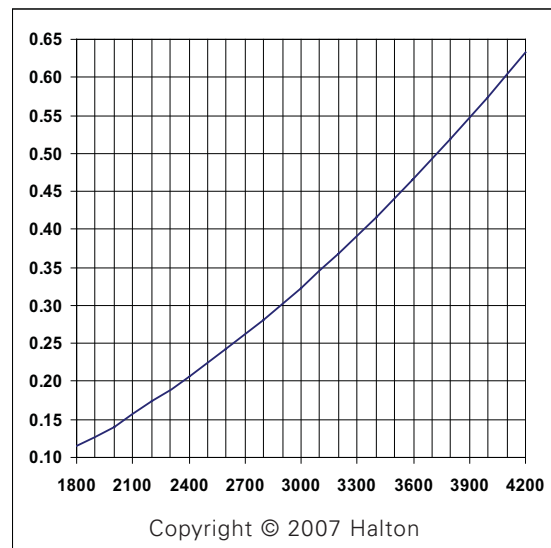

Suggested specifications

General

Kitchen hood inner liner shall be constructed from 18 gauge stainless steel where exposed. The kitchen hoods shall be supplied complete with outer casing / main body, inner liner, exhaust duct, pressure measurement T.A.B. ports,

Outer casing panels shall be constructed of stainless steel with a brushed satin finish. Each joint shall be welded and liquid tight, avoiding harmful dripping of condensation. All exposed welds are ground and polished to the original finish of metal. Canopy ends shall be double sided wall construction (no single wall hoods permitted).

Exhaust

The exhaust airflow will be based on the convective heat generated by the appliances underneath each hood system. Submittals shall include convective heat calculations based on the input power of the appliance served.

Capture Jet® with Side-Jet technology

The hood shall be designed with Capture Jet® with Side-Jet technology to reduce the exhaust airflow rate required, and to improve the capture and containment efficiency of the hood, while reducing energy consumption. The Capture Jet® air shall be introduced through a special discharge panel and shall not exceed 10% of the calculated exhaust airflow. The Capture Jet® discharge velocity will be a minimum of 1500 feet per minute. Slot or grille type discharge shall not be used. The Capture Jet® shall be internally mounted with a speed control and will not require a fire damper or electronic shut down in fire mode.

T.A.B. ports

The airflows through the extractors and the Capture Jet® air chamber are to be determined through the integral T.A.B. (Testing and Balancing) ports mounted in the hood. The airflows are to be determined by the pressure vs. airflow curves supplied by Halton.

Grease filters

The hood shall be equipped with KSA multi-cyclone stainless steel grease extractors. The KSA filters shall be NSF and UL classified. The grease extraction efficiency is 93% on particles with a diameter of 5 microns and 98% on particles with a diameter of 15 microns or larger as tested by an independent testing laboratory. The pressure loss over the extractor shall not exceed 0.50" of water at flow rates approved by U.L. for heavy load cooking. Sound levels shall not exceed an NC rating of 55. Baffle or slot type extractors shall not be used.

Light fixtures

Hood lights shall be U.L. listed incandescent type, suitable for grease hoods. Option: Recessed Fluorescent and Incandescent. The lighting shall be suitable for single phase power supply.

Control panel

The master electrical panel consisting of one starter per motor with overload protection will be supplied. Control panel to hood or remote mounted.

Fire Suppression System

The kitchen hood fire extinguishing system shall protect the kitchen hood against grease fires by a completely automatic fire control system, which consists of wet chemical. The fire detection system shall be capable of detecting fire in the hood, duct, or surface equipment and shall automatically discharge liquid extinguishing agent into the plenum chamber, exhaust duct collar, and cooking appliance areas to ensure against re-ignition or re-flash. System components shall include a spring-loaded fusible link detector, wall mounted emergency pull stations, wall mounted automan and cabinet, and a mechanical gas valve installed in the gas line serving the cooking equipment. System installation shall be made by an authorized representative of the system manufacturer and conform to U.L. 300 requirements and local codes.