

# Operators Manual

*Manual provides  
Installation, Operation, and Maintenance Instructions*



**Models : KVE (SJ-SK) KVC (SJ-SK), KVV (SJ-SK),  
KVR, KVO and KVL  
SWR / EO / DW / CH  
SWS / SBS / SIR5**



**Halton**  
CARE FOR INDOOR AIR

## GENERAL DESCRIPTION

All Halton Capture Jet® hood systems provide solutions for a variety of commercial foodservice ventilation applications over virtually any cooking process. Halton's Capture Jet® technology gives the most efficient system on the market. To achieve the optimum performance from your hood system (s) please use the following guidelines provided within the pages of this Installation, Operation, and Maintenance Manual.

In addition to this information our offices or local representatives are available at any time to provide additional technical support for products, applications, installation, commissioning or in any aspect that you may have.

## RECOMMENDATION

Upon receipt of the Halton hood (s), inspect unit (s) immediately for any shipping damage and notify carrier immediately if damage is found. Halton will not accept responsibility for any shipping damage. All systems are thoroughly inspected before leaving our factories, however Halton will assist in filing a claim if needed.

## GENERAL INSTALLATION

It is the responsibility of the installing contractor to see that the system installation is completed in accordance with the project plans and specifications and that it meets all specific requirements of local code officials. The local authority having jurisdiction could over rule some of the installation details written in this manual. The installation shall be in accordance with NFPA-96. All electrical systems shall be installed following local and national codes.

The owner and/or operator should be instructed in the proper operation, care and maintenance of the system.

If questions or complications should arise during the installation of the Halton hood (s) that cannot be solved using the instructions provided please contact the Halton office at 1-800-442-5866, or (**1-800-4-HALTON**).

**Note: There are no instructions contained within this manual for installation or maintenance of fan packages.**  
**\*\*See appropriate manufacturers manual for detailed instructions.**

## EXHAUST AIRFLOWS

Because the listed exhaust airflows rates were established under controlled laboratory conditions, please see submittal drawings or contact the manufacturer for exhaust air flow rates.

## INSTALLATION INSTRUCTIONS

1. Inspect the crating carefully. If there are signs of damage, call the freight carrier before uncrating the units. Carefully uncrate the units. Check all local codes prior to installation, special requirements may be necessary depending on local building material construction.

**\*\* Important note \*\* Do not leave unit (s) exposed to extreme temperatures for an extended period of time, this may cause the protective PVC coating around the unit (s) to become very difficult to remove.**

2. Position the hood near the actual installation site. In case of multiple hoods, check the engineered set of drawings for locations. Pay close attention to collar sizes and fire protection layouts, matching the hood systems to the correct location shown on the drawings provided.

**\*\*Check item numbers on crates / hoods vs. drawing item numbers.**

3. Once the hood is carefully removed from the shipping crate and set in position, the unit is now ready for installation. If Halton Company has supplied a backsplash assembly, then the splash assembly should be installed first, for installation procedures. **(See pg. 4)**

4. Hang the hood using ½" threaded rods by attaching the rods to the hood through the hanger brackets that are welded to the top of the hood. Use of turnbuckles will make final adjustment easier. Standard hanging height for canopy hoods ranges from 78" min. to 84" max. above the finished floor (per local codes having jurisdiction). **\*\*Noted in installation instructions - (see pg. 6).**

**\*\*All typical installations for Capture Jet® series hoods shown on pages 18-22.**

5. If Closure Panels are supplied by Halton **(see pg. 8)** for details on the installation.
6. For multiple hoods end to end, or back to back **(see pg. 7)** for Installation of Splice Strips and U-Channels.
7. For hoods equipped with a supply fire damper, it is very important to make sure that the fire damper is set in an open position before connecting the supply duct.

**For units with exhaust fire dampers, (see pg. 9), or supply fire dampers, (see pg. 10) for installation details.**

8. Electrical circuits should be connected according to standard switch panel wiring diagram, shown on **(pg. 11)**. For Halton Capture Jet® series hoods, a typical wiring diagram is shown on **(pg. 12)**.
9. Grease filters and grease cups must be installed in place before start-up.
10. Install 100 watt maximum light bulbs in standard incandescent lights or fluorescent bulbs (36" L or 48"L) in fluorescent lights. **\*\*Note: Halton does not provide bulbs.**
11. Protect the hood from damage under normal job site conditions, until all work is complete and system is ready to be put into operation.

## OPERATION OF SYSTEM

1. After installation is complete, it will be necessary to check and balance the airflows. On the Capture Jet® line of hoods, Halton supplies T.A.B. (testing and balancing) ports for measuring the pressure drop. These ports are located on the inside of the canopy on each plenum. (**Exhaust and Capture Jet®**).

For details on their use (**see pg. 13**). For hoods without ports, use of standard practices (duct traverse / average velocity / etc) for measuring airflows will be required.

**\*\*It is very important that the fan for the Capture Jet® air be balanced according to specifications. See the job specific information for required airflows. Adjustments to the Capture Jet® fan can be made with the speed controller supplied with the fan. This speed controller will be mounted inside or on top of the hood, or mounted in an electrical enclosure.**

**Information regarding the fan and speed controller (see pg. 12).**

2. Each Halton Capture Jet® hood system will have a “KSA” filter remover (**model KFR**). The “KFR” will be packaged separately, inside the hood, the box will be labeled “Attn: Kitchen Mgr. “ Model KFR instructions on (**pg. 14**). The KFR will assist in removal of the filters for assembly and cleaning.
3. After the exhaust and supply airflows have been properly balanced, a final inspection should be made to ensure proper system operation.

## HOOD MAINTENANCE

1. Clean the hood canopy inside and out as needed with mild soap and water. Never use harsh or abrasive cleaners on Stainless Steel or Painted surfaces, making sure to wipe clean all interior and exterior surfaces of the hood including the light fixtures.

**\*\* Never clean the hood canopy when any of the surfaces are hot.**

2. Clean the filters and grease cup(s) daily, first washing by hand, and then placing them into a dishwasher or by steam cleaning.

**\*\* Handle the Grease filters carefully \*\***

# 1" Insulated Backsplash Assembly

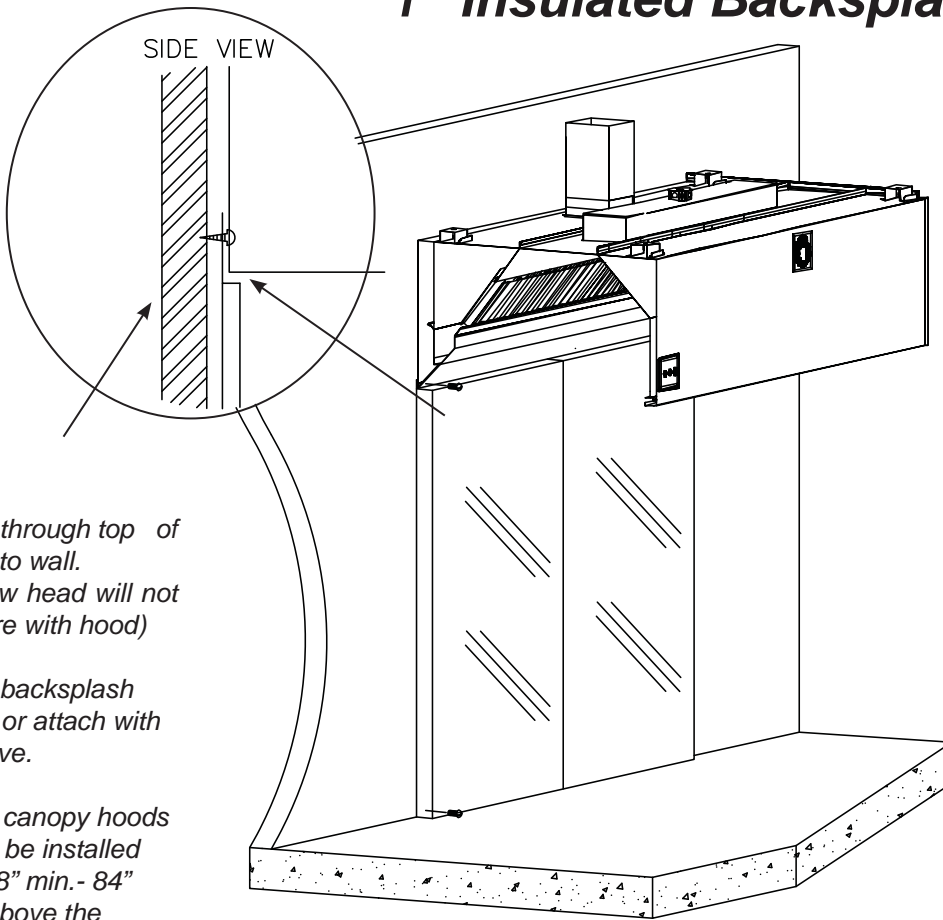

Screw through top of flange to wall.  
 \*( screw head will not interfere with hood)

Screw backsplash to wall or attach with adhesive.

Halton canopy hoods should be installed from 78" min. - 84" max. above the finished floor.

# Flat Sheet Backsplash Assembly

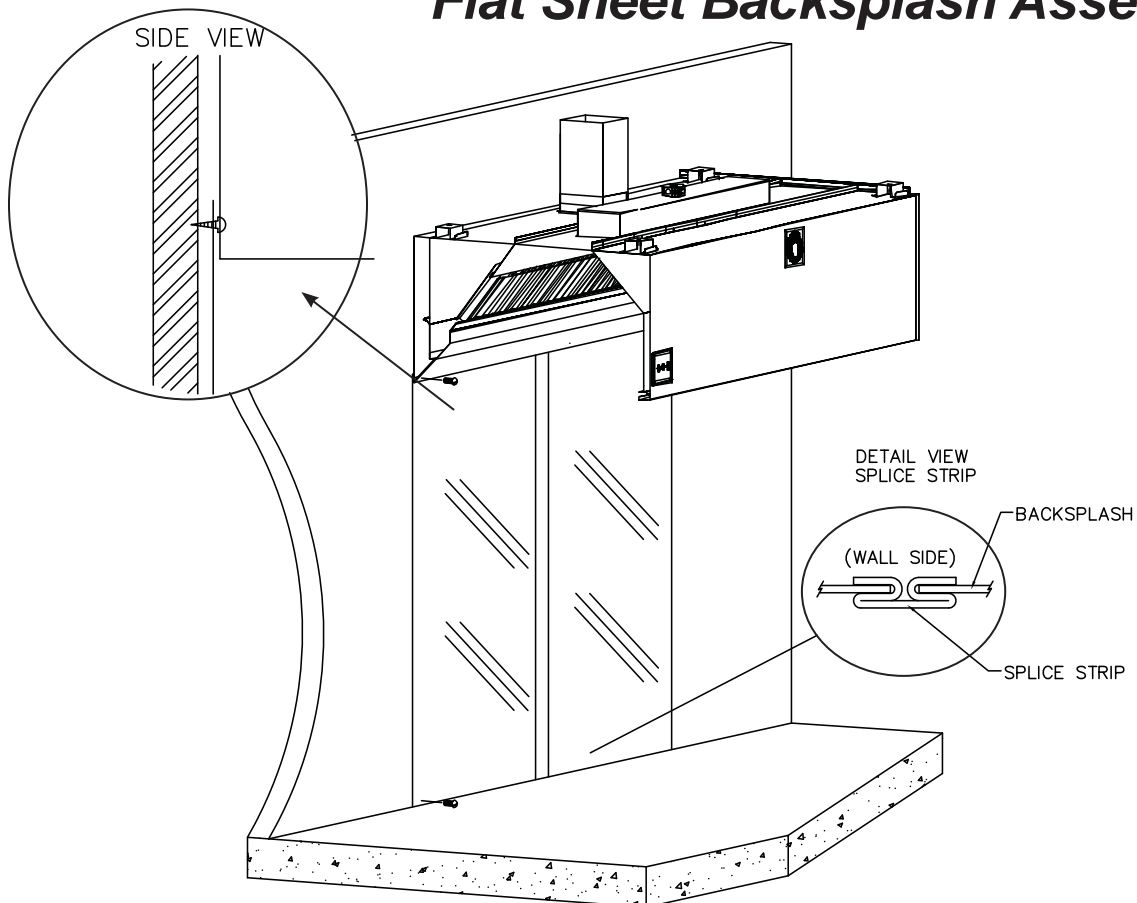

DETAIL VIEW  
 SPLICE STRIP

BACKSPLASH

(WALL SIDE)

SPLICE STRIP

## Typical Hood Installation Details

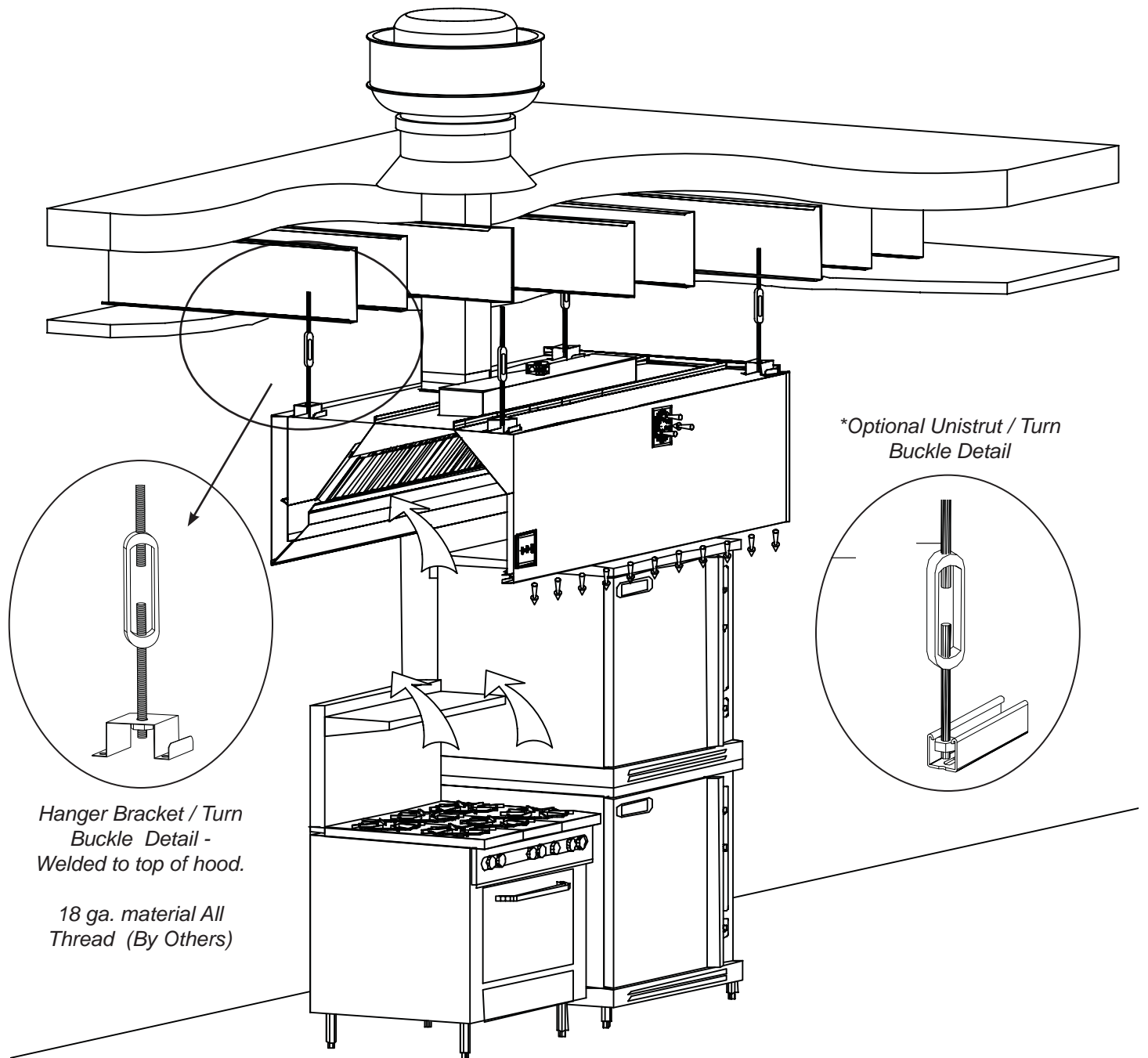

Hanger Bracket / Turn  
Buckle Detail -  
Welded to top of hood.

18 ga. material All  
Thread (By Others)

\*Optional Unistrut / Turn  
Buckle Detail

Hang the hood using 1/2" threaded rods by attaching the rods to the hood through the hanger brackets (as shown) which are welded to the top of the hood, using the turnbuckles will make final adjustments easier. Hanging height of Canopy hoods should be **per local building codes, verify with "Authority Having Jurisdiction"** for hanging height in your project location.

**Standard hanging height is 78" minimum to 84" maximum above the finished floor.**

# Recommended Exhaust Duct Installation Details

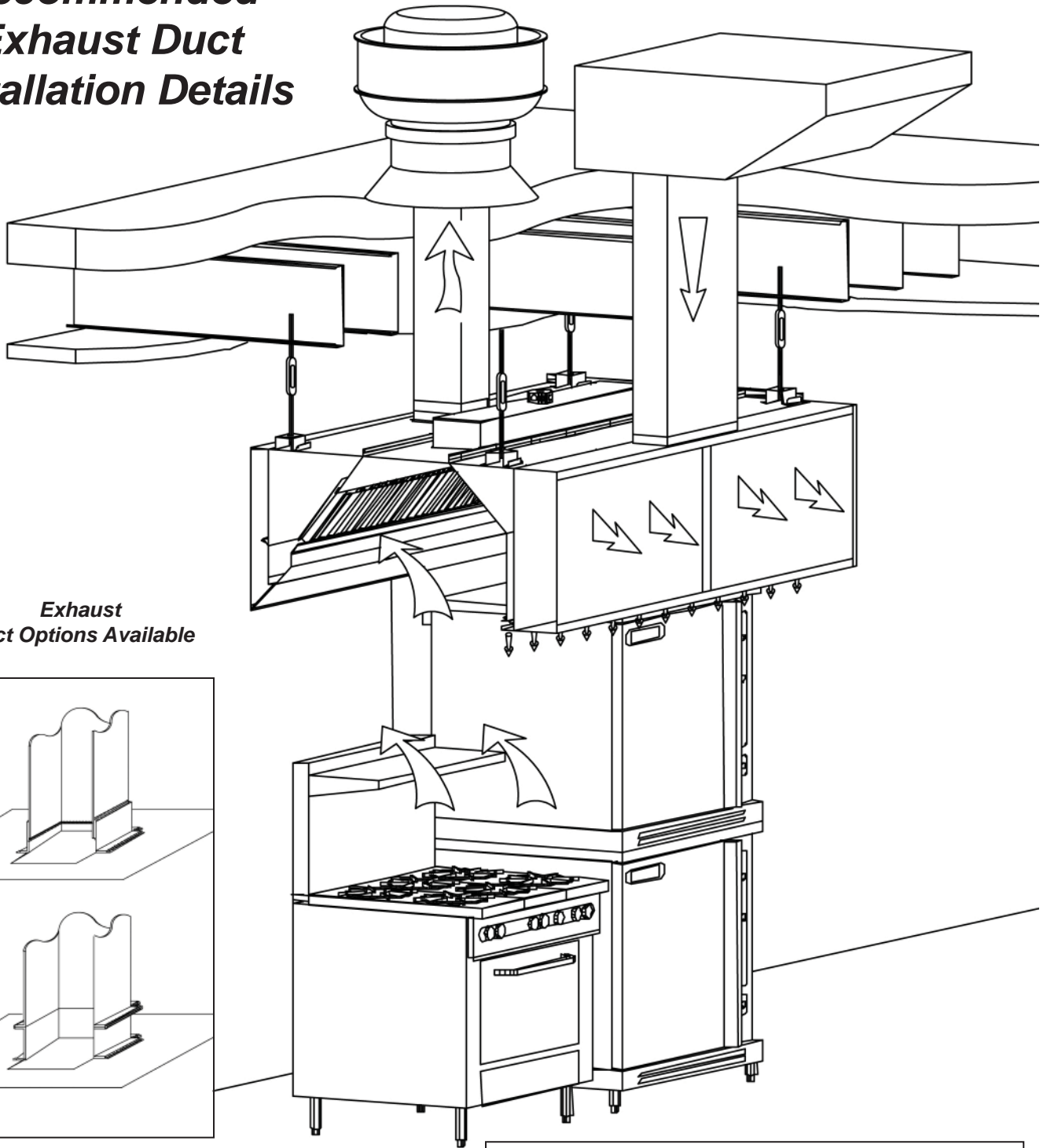

**Exhaust Duct Options Available**

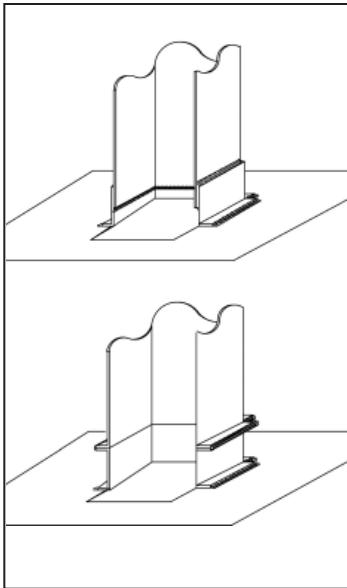

## Supply Duct

Supply Duct may be attached to supply collar with sheet metal screws or pop rivets and sealed with duct tape.

Screws or Rivets are not to interfere with the operation of the fire damper (if equipped).

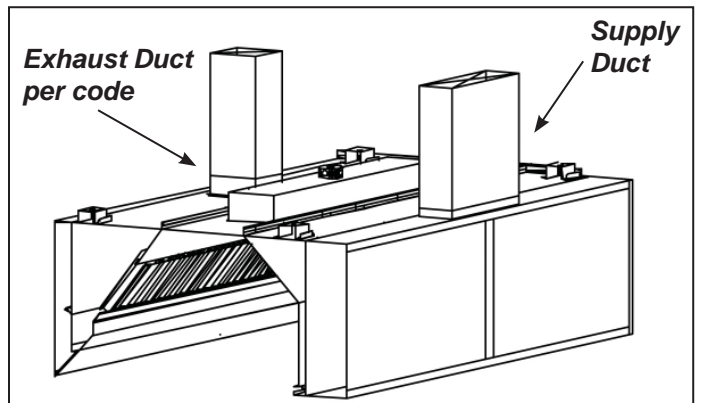

# Splice Strip / U-Channel Assemblies

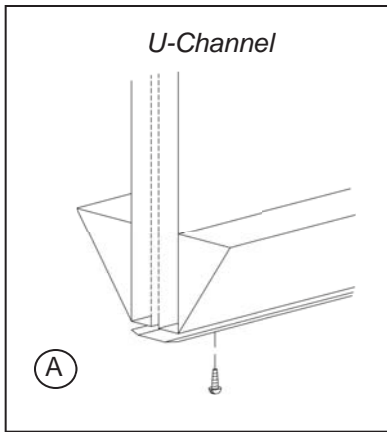
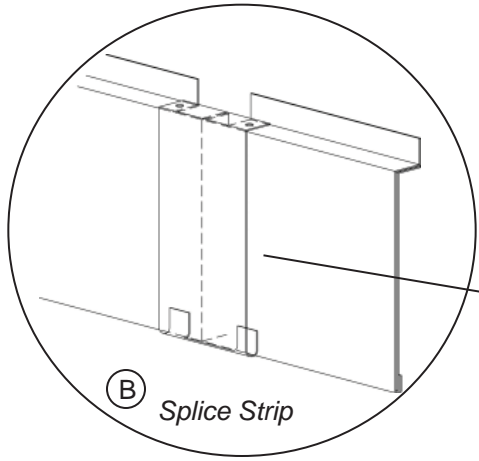
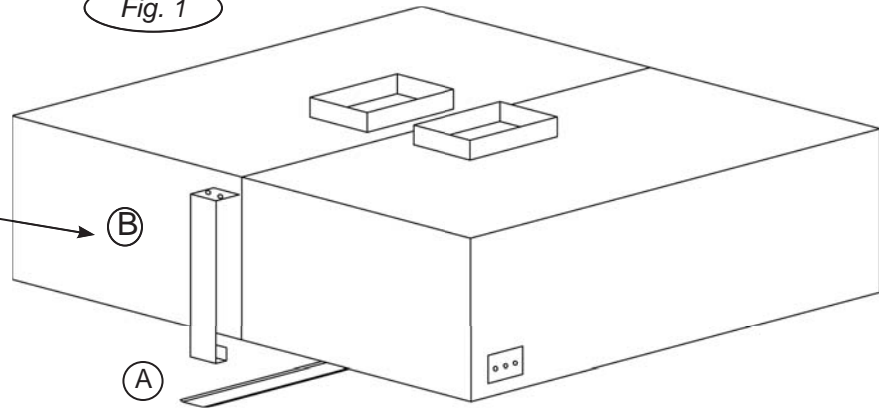

Fig. 1

Hoods shown back to back



## Installation Notes:

### U-Channel:

For hood models that are placed **back to back** (as shown in Fig. 1): Slide the U-Channel (A) up over the back of the hood systems, and secure with sheet metal screws.

For hood models that are placed **end to end** (as shown in Fig. 2): Pry apart the U-Channel at one end and slide over the end panels, fastening in place, fitting around the perimeter of the hood systems.

### Splice Strip:

For hoods placed **back to back**: Slide Splice Strip (B) over bottom of hoods first, then over top, secure by welding together.

For hoods placed **end to end**: Slide over bottom front edge first then over top, secure by welding together, or as an option using screws for models with supply plenum.

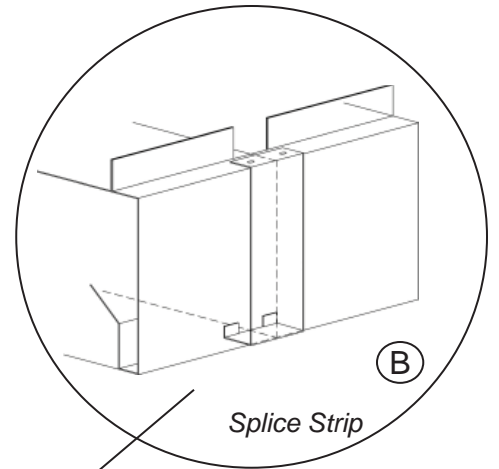
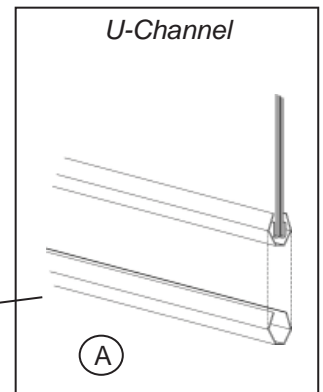
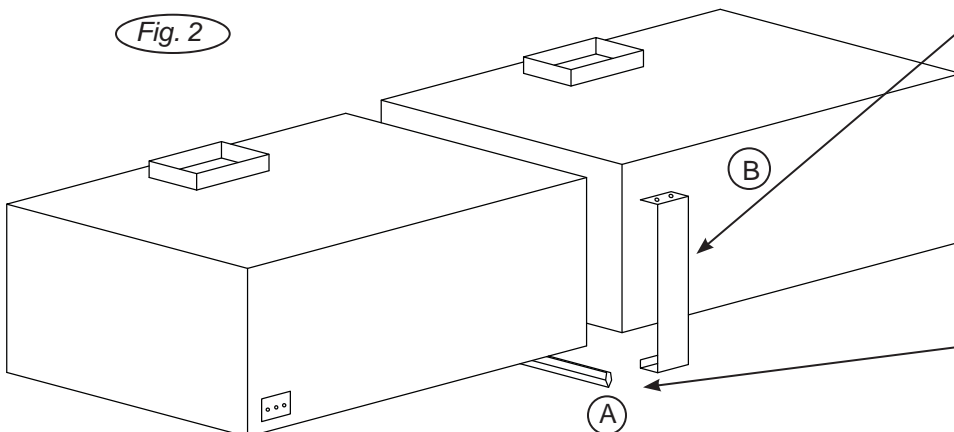

Fig. 2

Hoods shown end to end





# Closure Panel Assembly

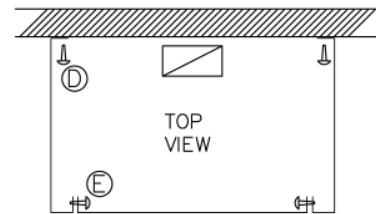
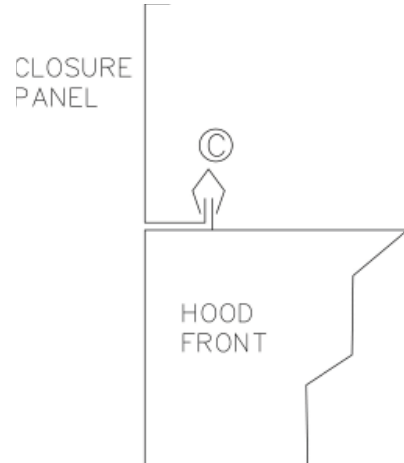
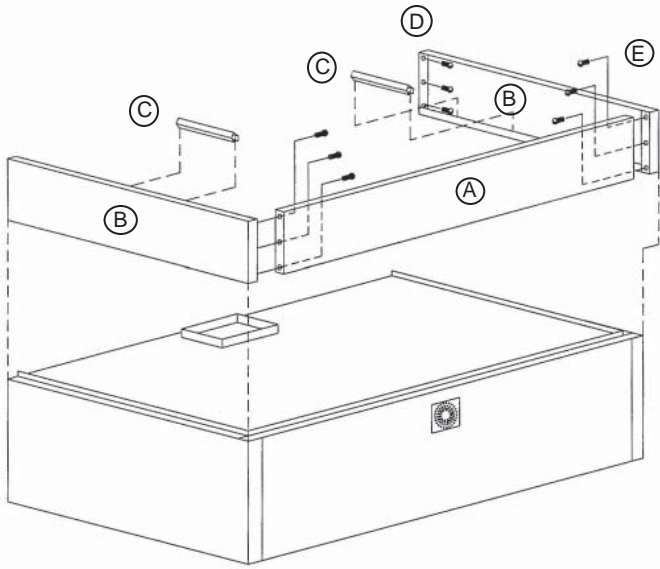

## Installation Notes:

- 1) Panels "A" and "B" are to set on top of the hood perimeter.

*\*Vertical flange at the bottom of closure panel and vertical flange on top of hood should line up.*

- 2) Hammer clips "C" over the two vertical flanges.
- 3) Attach panels "B" to wall using appropriate hardware "D".
- 4) Slide front panel "A" into place.
- 5) Attach panels "A" and "B" together using hardware "E"  
\*(Hardware not provided by Halton)

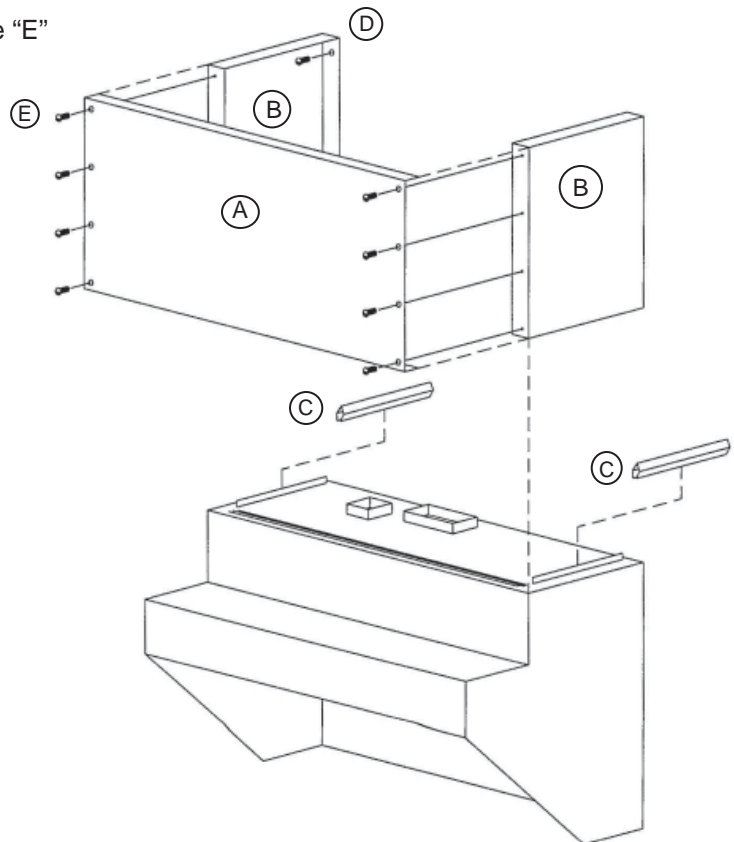
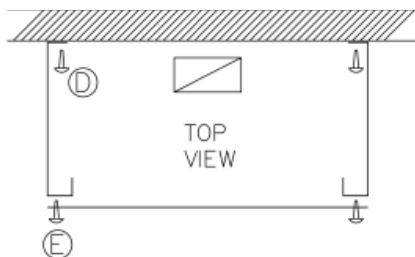
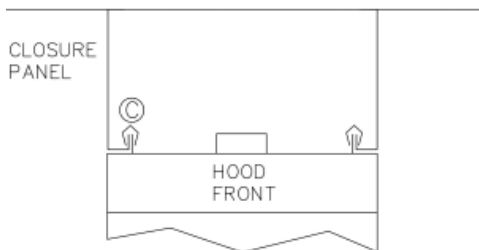

# Exhaust Fire Damper Assembly

**Optional in Models : SWR / SWS / SIR5 / DW / KVE / KVC / KVV**

1. Remove grease filters.
2. Uncoil Stainless Steel cable attached at clip (A)
3. Thread end of cable from eyebolt at clip (A) going through eyebolt at clip (B), then thread through eyebolt at clip (C).
4. Hold fire damper in maximum open position to attach "S" hooks at point (D), close "S" hooks to secure.
5. For final adjustment of fire damper, tighten eye bolts at clips (A), (B) and (C) so that cable has no slack, and assure maximum open position is obtained.

\*\* (Access to fire protection exhaust duct nozzle to be provided by others)

**The collar is supported by a 1/2" flange located on the inside perimeter of the damper.**

Secure "S" hook to damper as shown.

\*\*Located in below detail as (D).

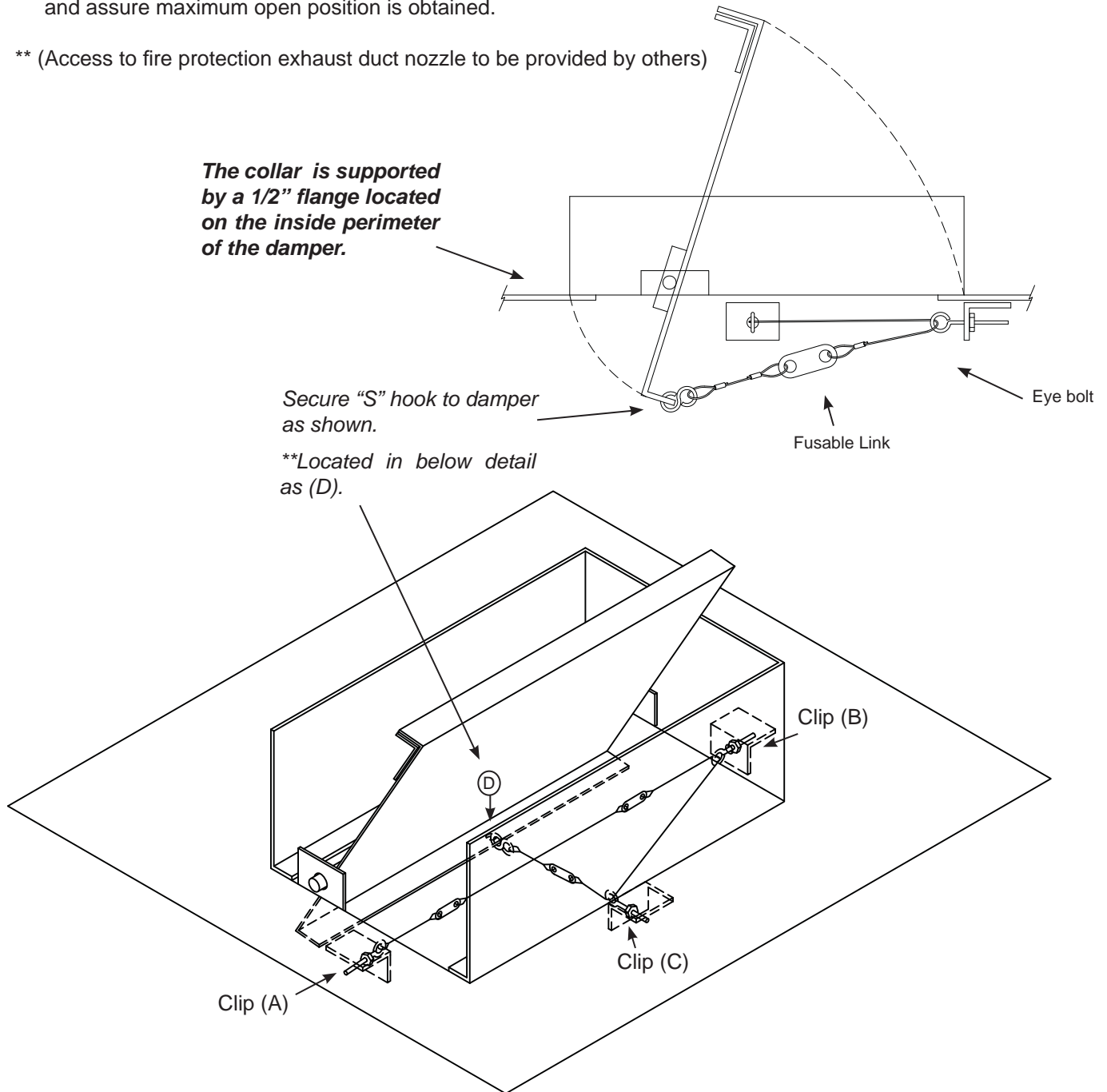

# Supply Fire Damper Assembly

**Optional in Models: SWR / SWS / SIR5**

1. It is important that damper is set in open position before installing supply duct.
2. Hold damper in maximum open position, fasten "S" hook at end of stainless steel cable onto the hole located in the middle of the supply fire damper flange, closing ends of the "S" hook to secure.
3. On final adjustment of the supply fire damper, tighten cable using eyebolts to assure maximum open position.

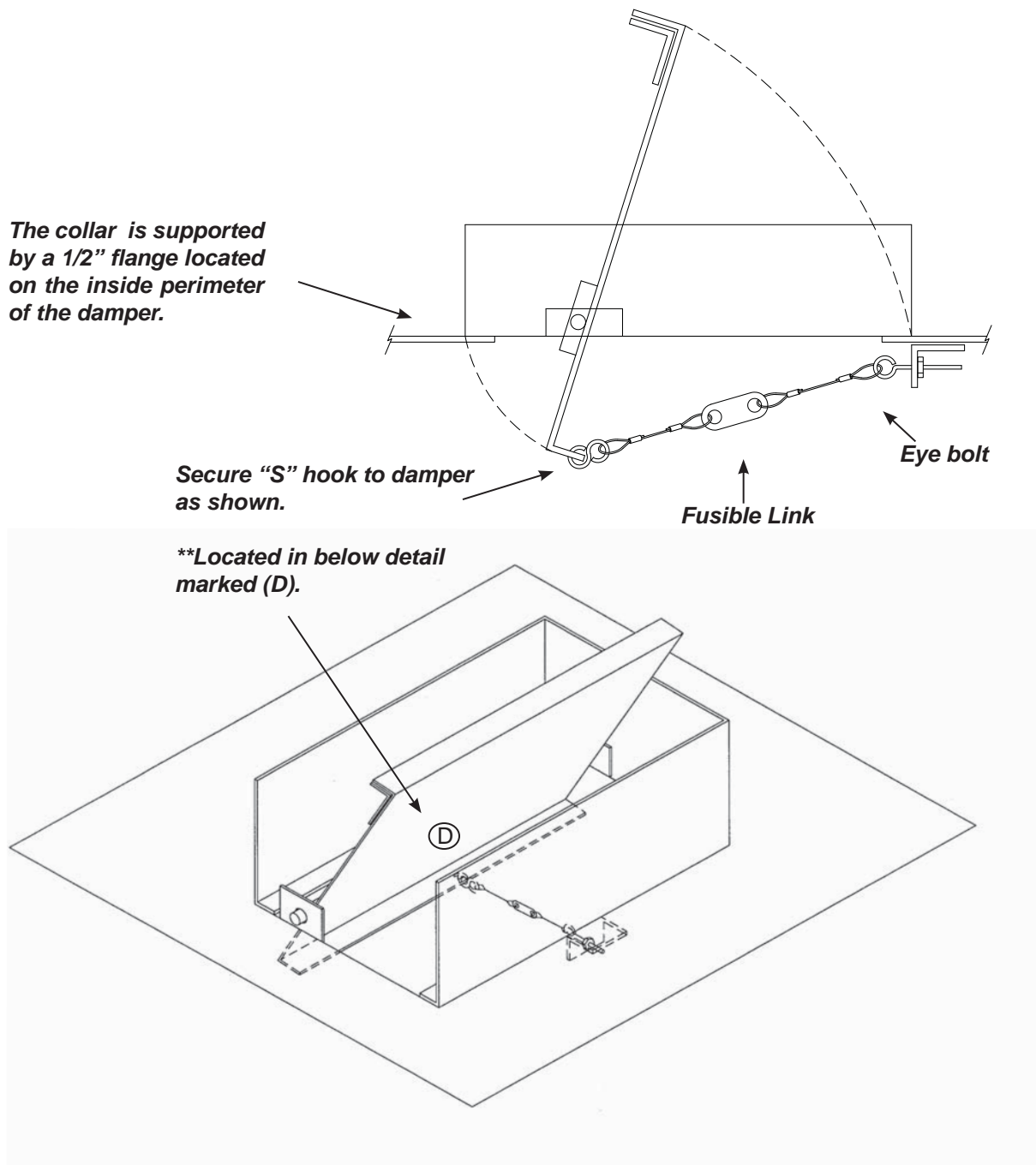

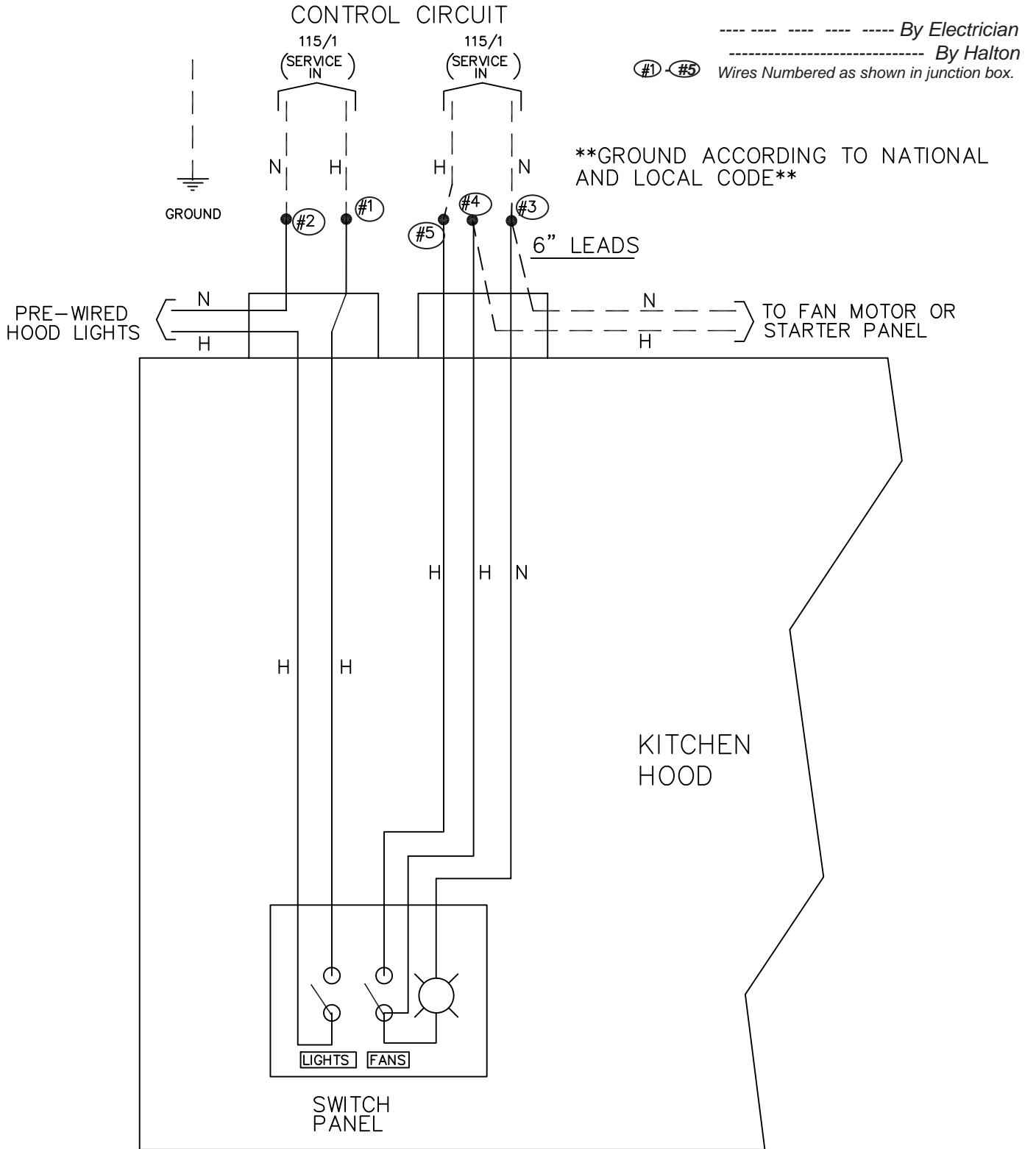

# Standard Switch Panel Wiring

\*(For Hoods not equipped with Capture Jet®)

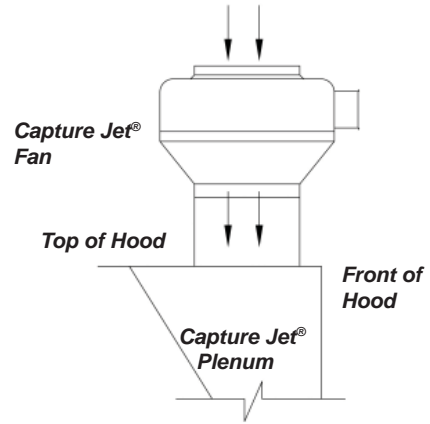
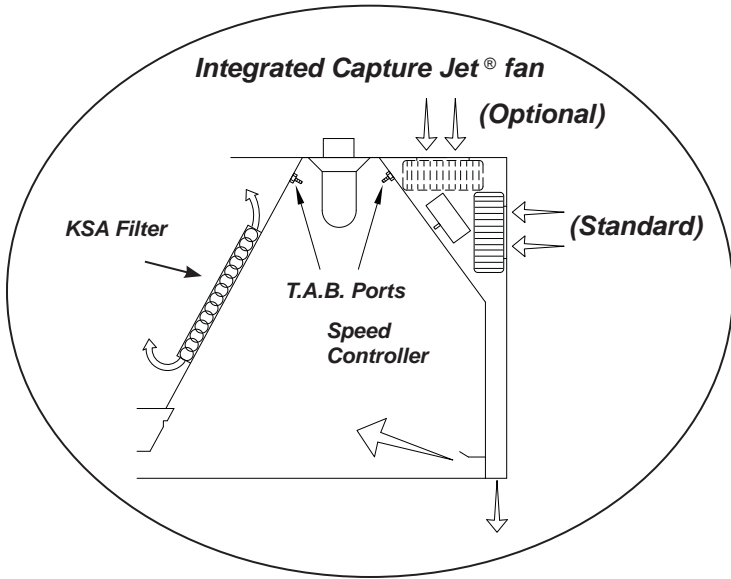

This style is standard for Model KVL



  5 AMP Speed Controller wired on top of hood or located in the Control Panel

Models KVE, KVC, KVR and KVV are equipped with an Integrated Capture Jet® fan package, as shown above.

## Typical Wiring of Capture Jet® Fan w/ Halton supplied Switch Panel

————— BY HALTON  
----- BY ELECTRICIAN

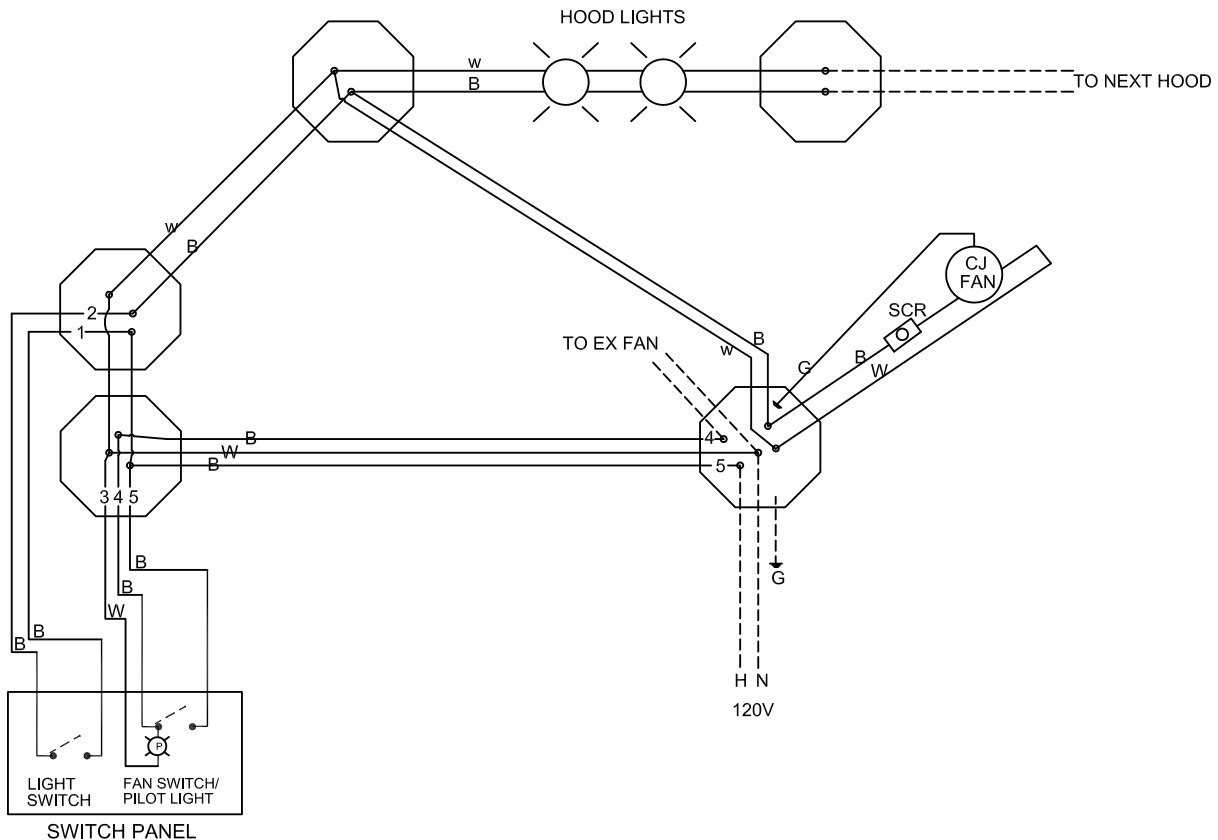

# T.A.B.<sup>TM</sup> - Testing and Balancing Ports

Capture Jet <sup>®</sup>	T.A.B. Port Readings
Hood Model	Design T.A.B. (inches WC)
KVE/KVC	0.20
KVW	0.20
KVR	0.20
KVL	0.29

This example shows how to determine the correct T.A.B. port reading for the exhaust hoods.

In this example, a design airflow of 1700 cfm is selected from the Airflow axis, and a vertical line is drawn up to the T.A.B. pressure curve for this hood.

A horizontal line is then drawn for the T.A.B. pressure curve to the T.A.B. reading axis on the left-hand side of the chart and the corresponding pressure is read off the chart as 0.19 inches of Water Column.

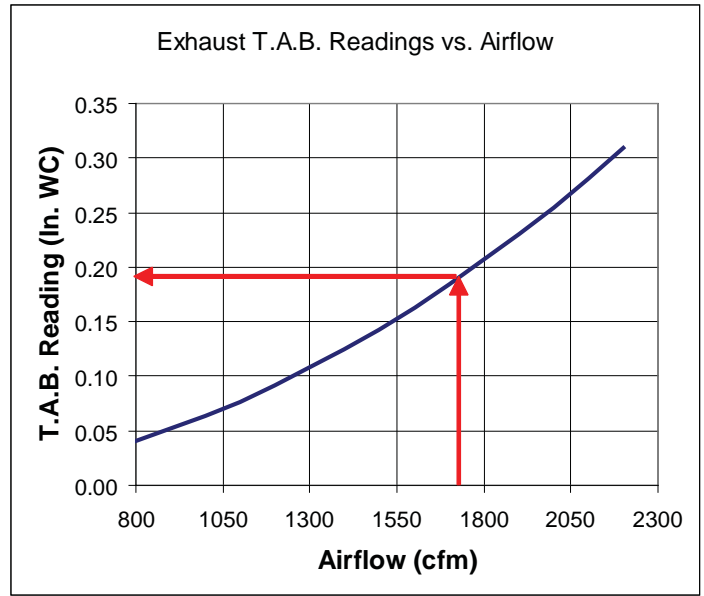

**Measured Pressure**

*The Capture Jet<sup>®</sup> and exhaust air flows are easily and accurately determined by measuring the pressure difference from the T.A.B. (Testing and Balancing) ports mounted in each plenum. The corresponding air flows can be read from the diagram provided.*

*To properly measure T.A.B. port readings use a magnehelic gauge or digital manometer and for exhaust plenum reading hookup hose from negative connection on instrument to T.A.B. Port on exhaust plenum. Leave positive connection on instrument open to atmosphere.*

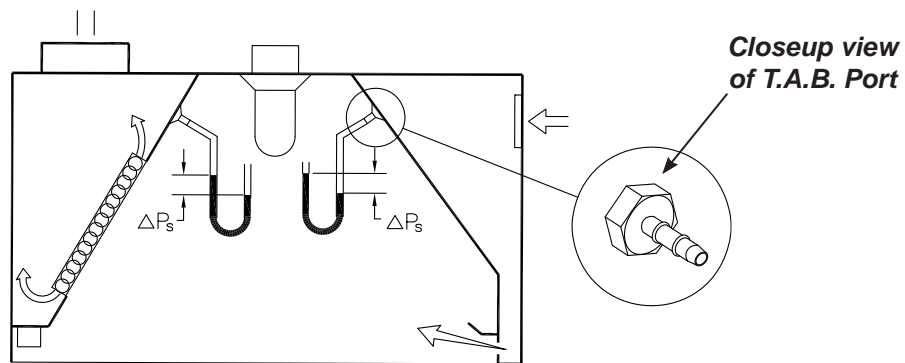

\*\*\*\* It is very important the cooking equipment is in operation to create a thermal plume, prior to the air balancer, to be able to use the T.A.B. ports.

\*\*\*\*For accurate results, the balance contractor should receive a copy of the job specific hood plans with the design T.A.B. readings from the hood supplier prior to balancing.

# KSA Filter Removal with Model KFR

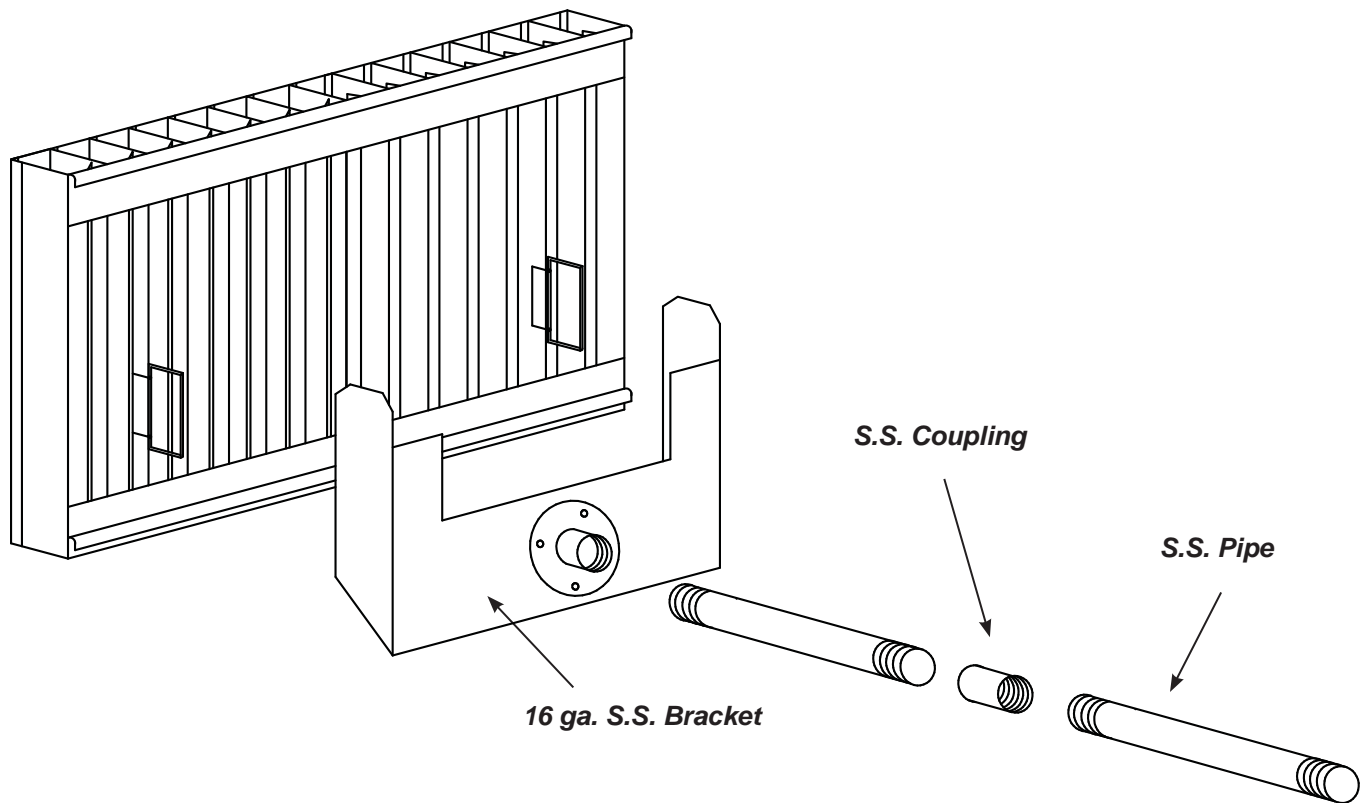

## To assemble the KFR filter remover:

Screw together stainless steel pipe, coupling, and bracket and tighten all joints.  
(as shown in above picture)

## Filter Installation and Removal

### To remove filter:

Insert bracket into the inside KSA filter slots, and lift upward until filter slides out of plenum.

### To install filter:

Place filter on KFR (filter removal tool) bracket, raise filter into place inside exhaust plenum. Slide upward until top lip of filter is locked into place and bottom lip of filter slides in place inside the exhaust plenum.

\*\*\* It is very Important to lock top lip of filter in place in installation as shown in reference drawing.

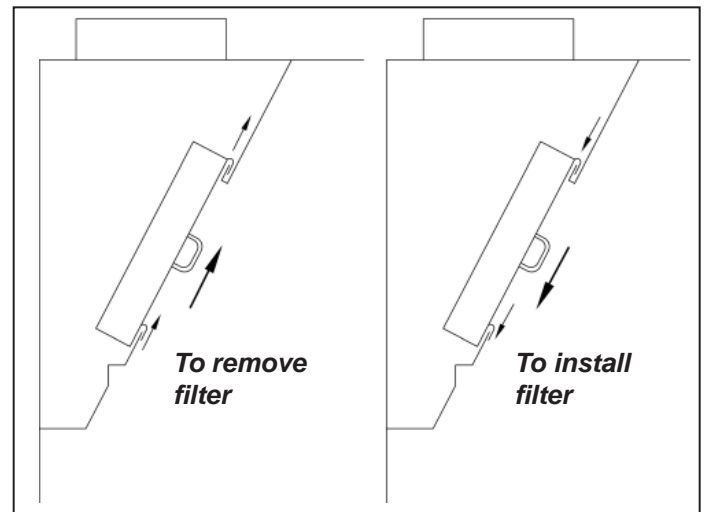

## Round / Oval Style Hood Systems Model KVR & KVO

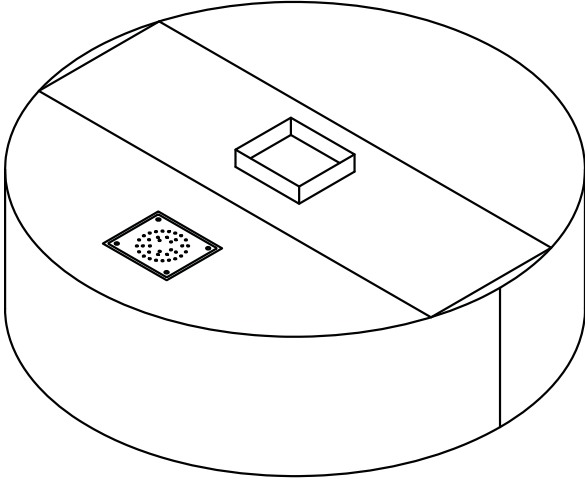

**3D Plan view of round KVR**

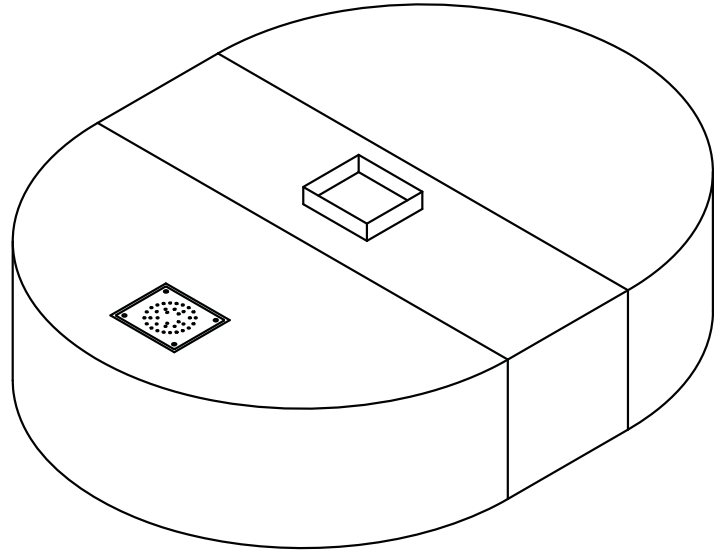

**3D Plan view of oval KVR**

Model KVR Round and Oval hoods can be shipped in pieces for field assembly. If pieces are shipped loose, parts will be marked for easy assembly, and an Operation and Installation, and Maintenance manual will be provided.

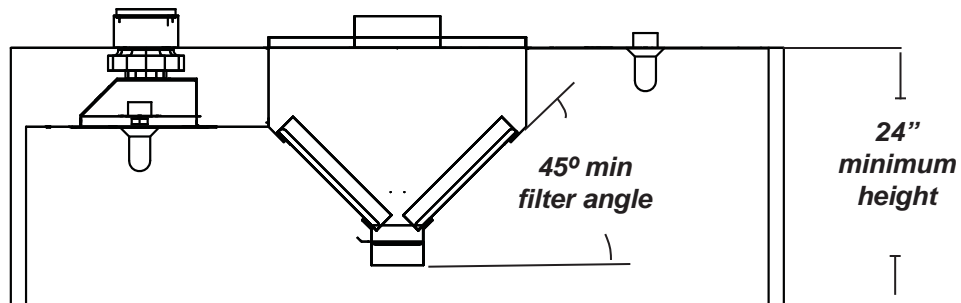

**Cross section of KVR**



# Model EO Typical Installation

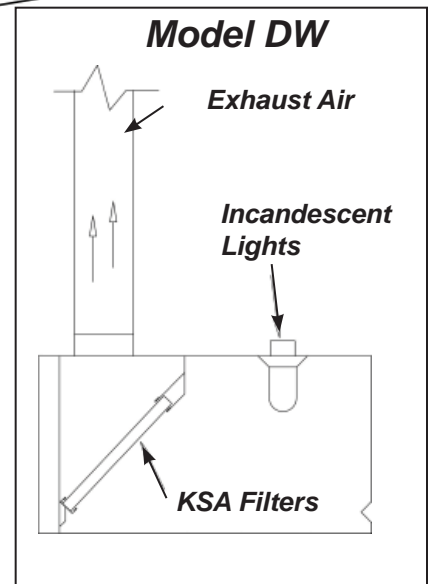
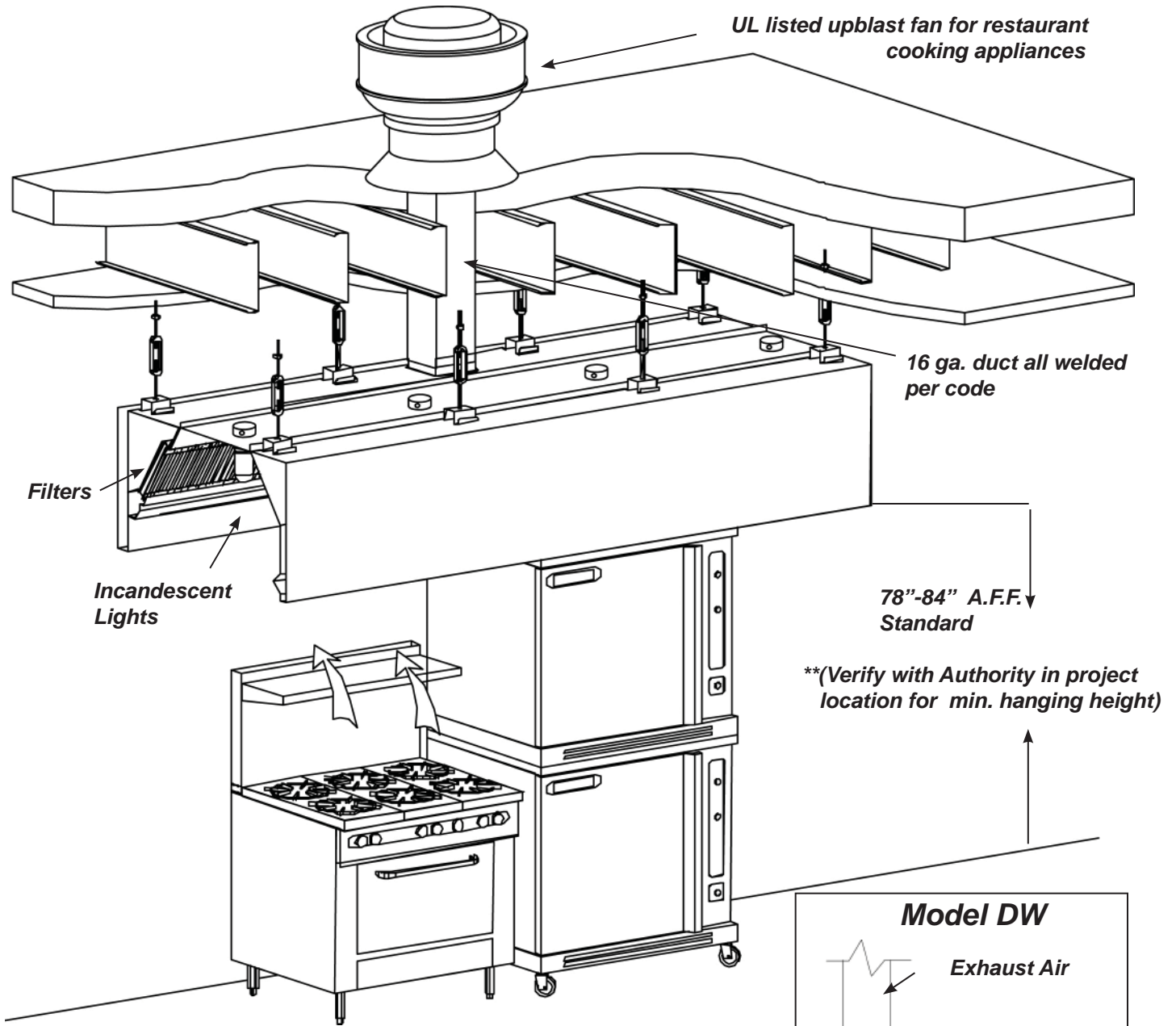

# Model CH Typical Installation

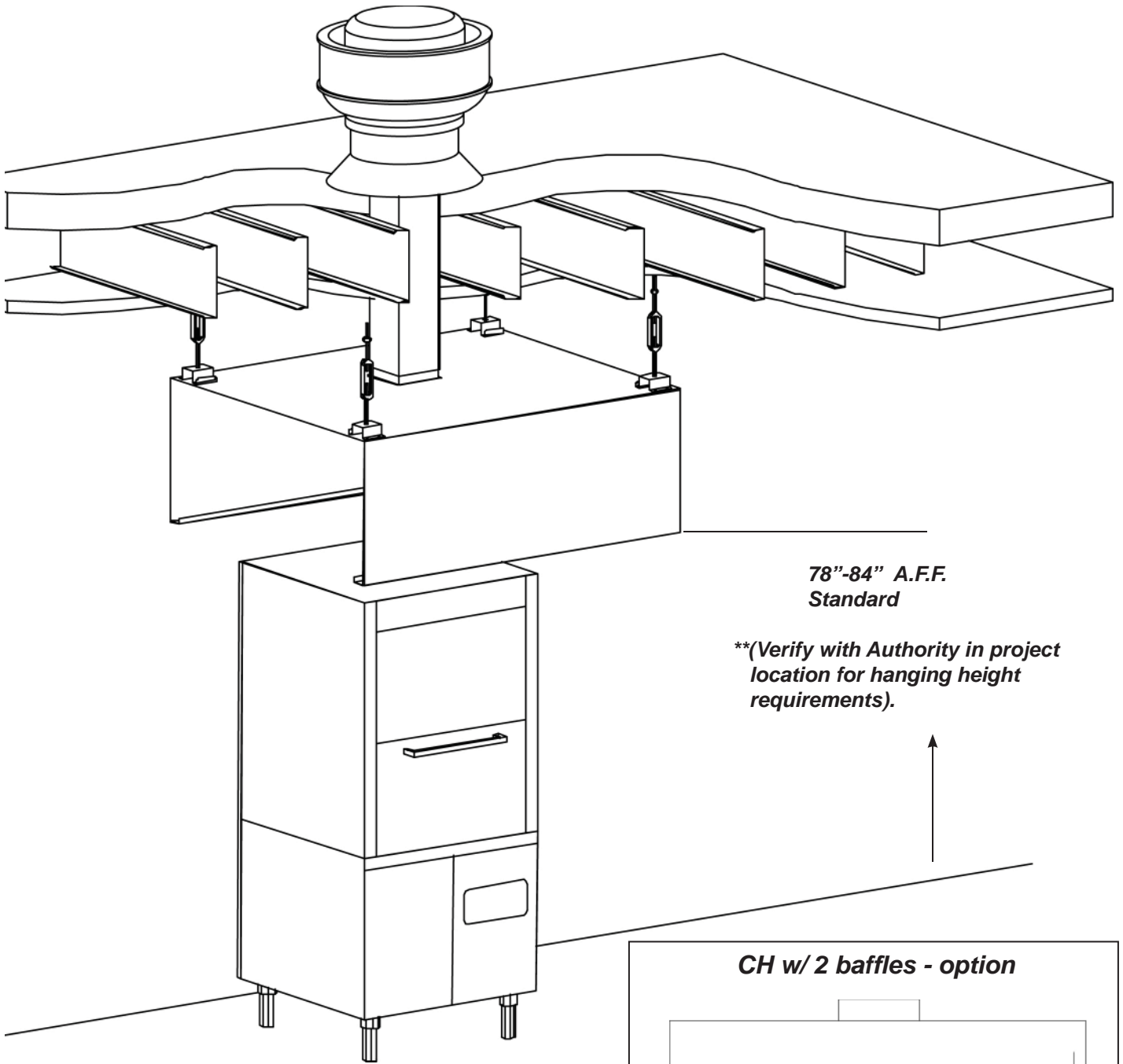

78"-84" A.F.F.  
Standard

**\*\* (Verify with Authority in project location for hanging height requirements).**

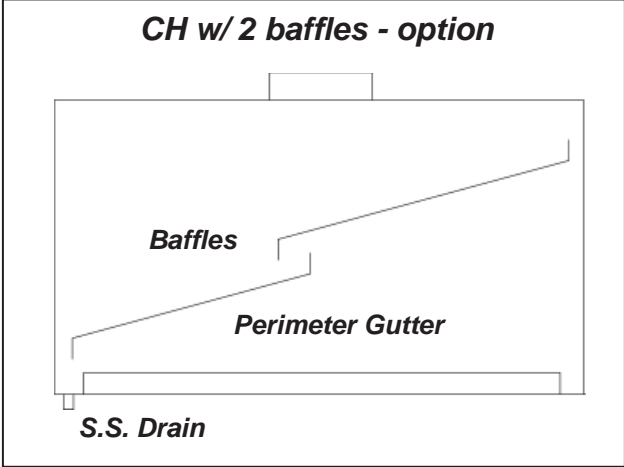

**\*\* Available with and without baffles**

# Model KVE Typical Installation

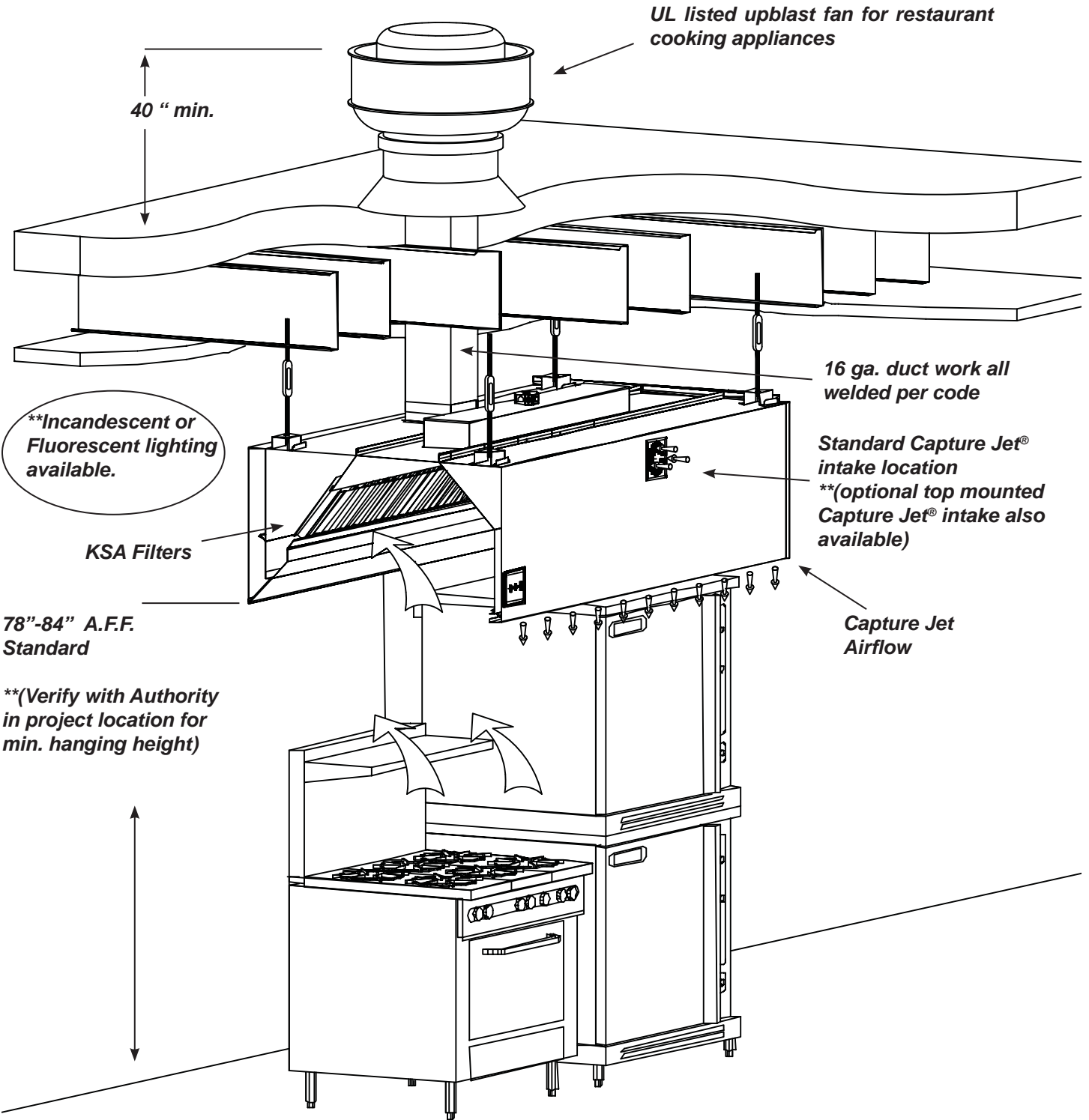

# Model KVC Typical Installation

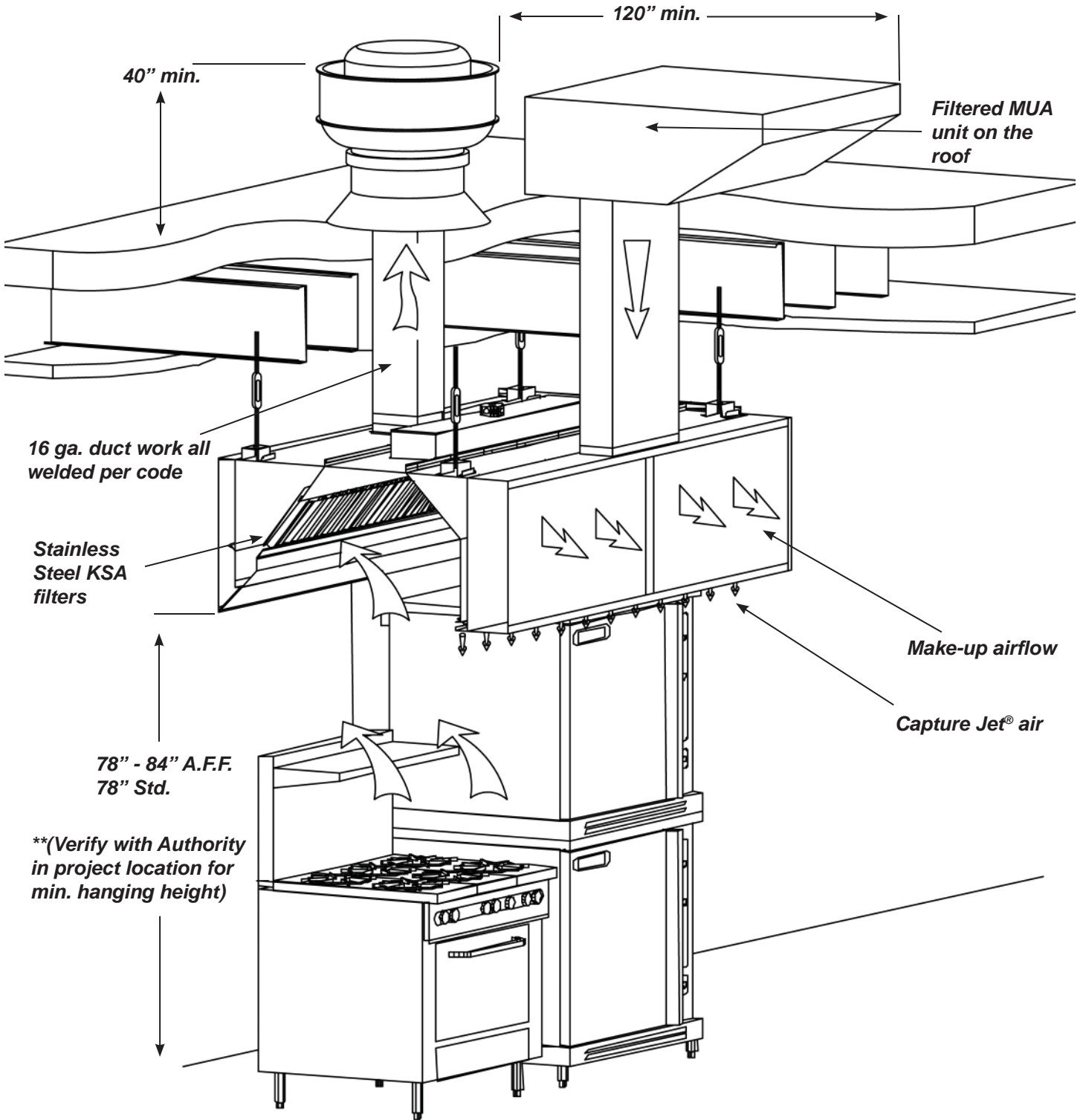

# KVL Typical Installation

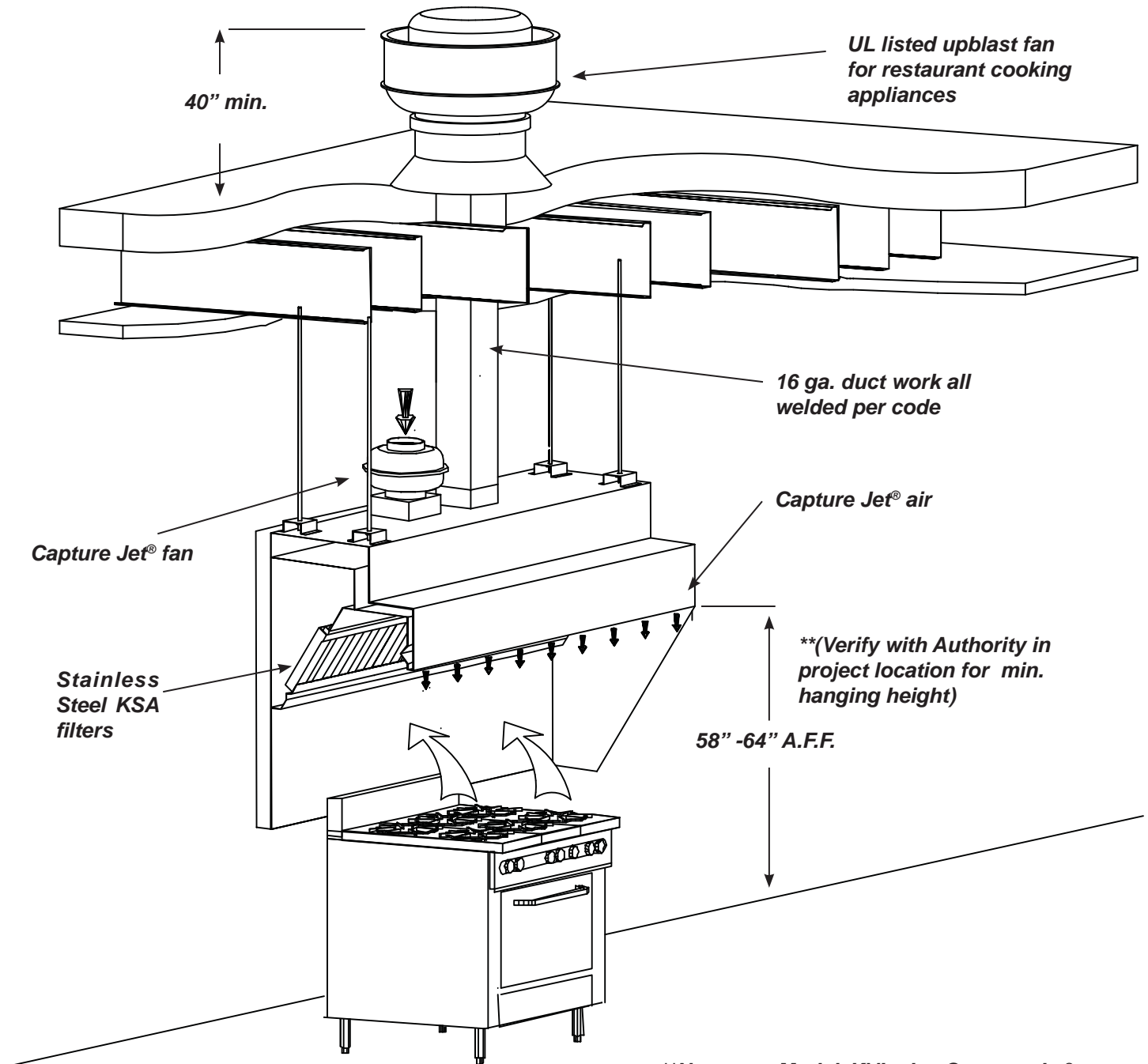

UL listed upblast fan  
for restaurant cooking  
appliances

40" min.

16 ga. duct work all  
welded per code

Capture Jet® air

Capture Jet® fan

Stainless  
Steel KSA  
filters

\*\* (Verify with Authority in  
project location for min.  
hanging height)

58" -64" A.F.F.

\*\*Note: on Model KVL the Capture Jet®  
fan is mounted on top of hood .

# Model KVV

## Typical Installation

See page (22) for supply options

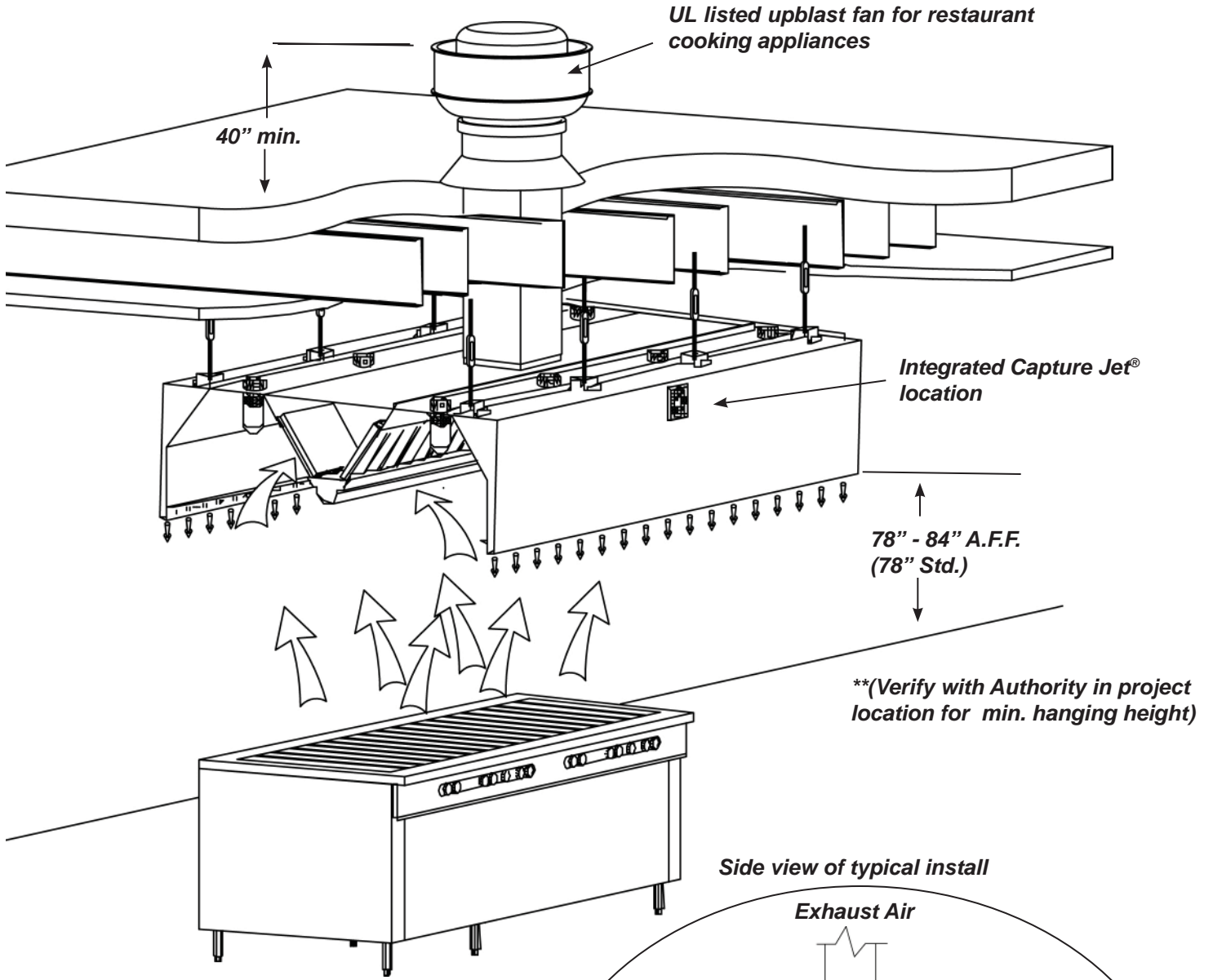

Side view of typical install

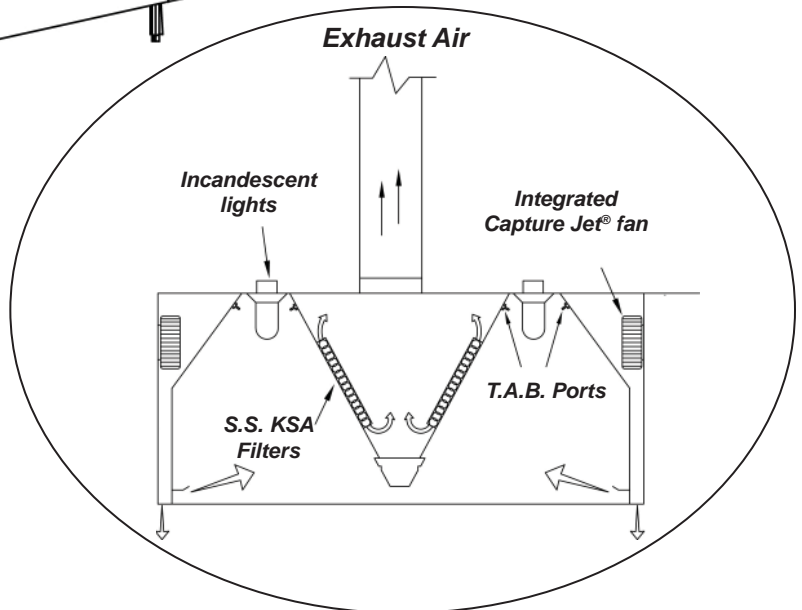

# Model KVV Typical Installation

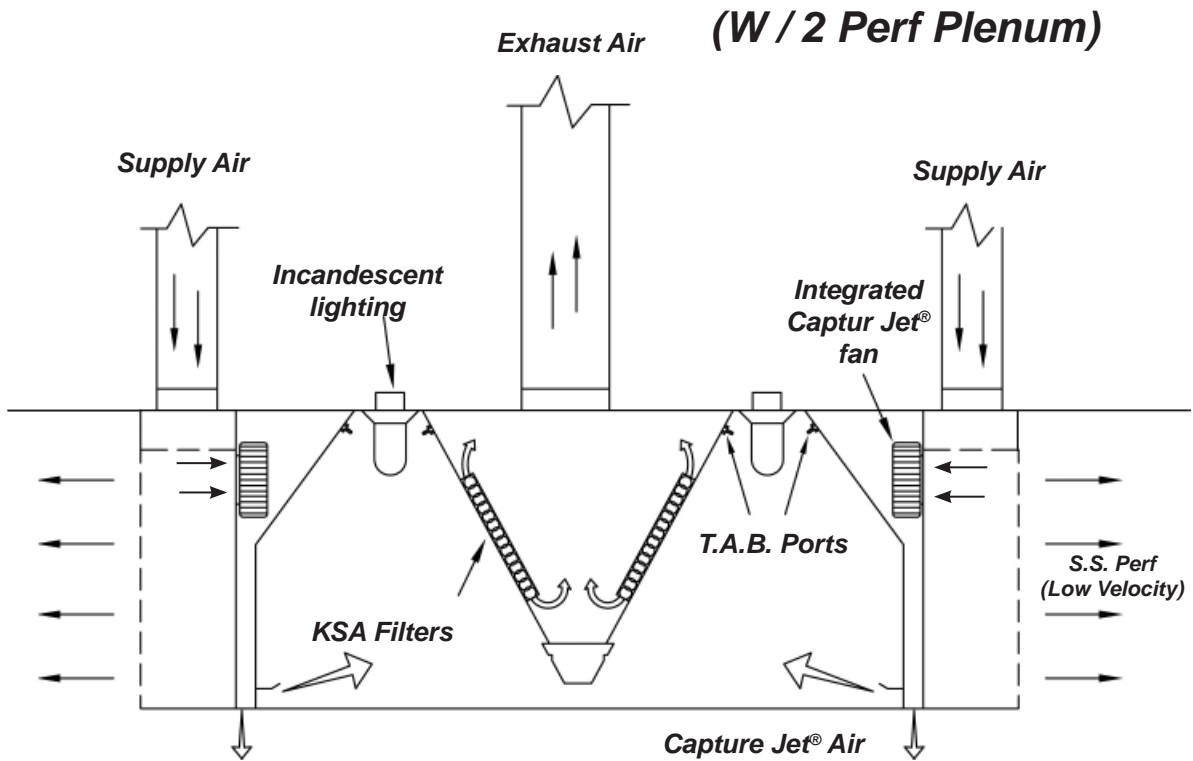
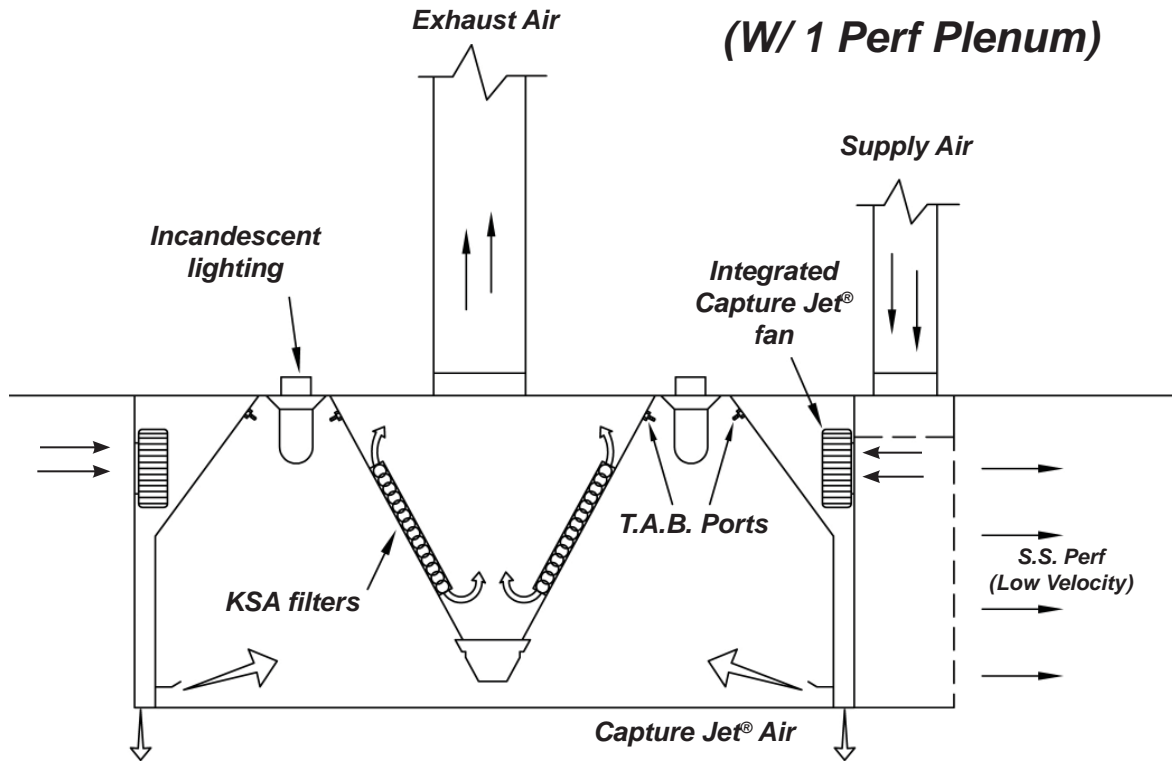

# HALTON LIMITED WARRANTY

Halton ("Manufacturer"). Warrants only to its direct purchasers and to no others, that all products manufactured by the Manufacturer shall be free from defect in materials and workmanship for a period of twelve (12) months from the date of the original installation and start-up or eighteen (18) months from date of shipment, whichever occurs first. All products sold but not manufactured by Manufacturer will be warranted for a period of twelve (12) months from date of shipment.

For products manufactured by the Manufacturer we agree to pay any reasonable labor costs necessary to repair or replace, at Manufacturers option, defective parts or materials for a period of twelve (12) months from date of original installation and start-up or eighteen (18) months from date of shipment, whichever occurs first. All labor costs subject hereto shall be performed during standard work hours at straight-time rates.

For products sold but not manufactured by the Manufacturer we agree to pay any reasonable labor costs necessary to repair or replace, at Manufacturers option, defective parts or materials for a period of (90) days from date of original installation and start-up or (12) months from date of shipment, whichever occurs first. All labor costs subject hereto shall be performed during standard work hours at straight-time rates.

Purchaser shall pay incurred premium labor charge, including overtime, weekends and holidays. Travel time, service charges, miscellaneous tools, material charges, and labor charges resulting from inaccessibility of equipment will not be paid by Manufacturer.

This **LIMITED WARRANTY SHALL APPLY ONLY** to products that have been installed and maintained in accordance with the installation and Care Instruction Manuals. Purchaser shall be solely responsible for adhering to the instructions and procedures set forth in the said instruction manuals.

This **LIMITED WARRANTY SHALL NOT BE APPLICABLE** to any damage or defect resulting from fire, flood, freezing or any Act of God, abuse, misuse, accident, neglect or failure to adhere to all instructions set forth in the installation and Care Instruction Manuals. Furthermore, this limited warranty shall not apply to any product that has been altered, unless such alteration has been approved in writing by a duly authorized representative of the manufacturer. In no event shall the manufacturer be liable for any loss, expense, personal injury or consequential damage, of any kind or character, as may result from a defect in material, and/or workmanship, however caused.

**EXCEPT AS IS EXPRESSLY SET FORTH IN THIS LIMITED WARRANTY, MANUFACTURER MAKES NO WARRANTY OF MARKETABILITY FOR FITNESS OR ANY PARTICULAR PURPOSE. NEITHER DOES MANUFACTURER MAKE ANY WARRANTY, EXPRESSED OR IMPLIED, WITH RESPECT TO PRODUCTS SOLD BY MANUFACTURER OR AS TO THE USE THEREOF.**

Continuous product improvement is a Halton policy, therefore specifications and design are subject to change without notice.