

# 8000 CFM

## EcoloAir™ System



© Halton

Accepted For Use  
City of New York  
Department of Buildings  
MEA 321-06-E



### Features & Benefits

- At least 95% of all grease and smoke particles are removed, per ASHRAE standard 52.2-2007, over the service life of the filters mitigating fire hazard.
- Cooking odors are reduced to minimal levels.
- Complete system can be located in the ceiling space, on the roof, or in a designated mechanical room.
- Each EcoloAir Module can be assembled and installed as one common unit or individually installed in separate areas.
- Commercial kitchens can now be located in areas where there are no provisions for grease exhaust.
- ECOsystem, which maintains design air volume during filter loading, is standard, providing an average of 20% reduction in exhaust over filter life, reduced tonnage required on HVAC design, green benefit with reduction in energy usage and operating cost reductions.
- A complete Halton EcoloAir System includes a Halton Capture Jet hood, EcoloAir Filter Module, Odor Reducing Module, ECOsystem, Fan Module & Control Panel.

### Application

Ventilation is the critical factor to consider when investigating the feasibility of a new commercial kitchen site. New projects, new design to existing buildings, and non-traditional sites often require uncommon solutions for kitchen ventilation problems. EcoloAir™ may be your solution to code requirements, environmental standards, multi-story structures, high installation costs, limited roof top space, historical/architectural sites or multi-restaurant applications.

# FILTER MODULE

**EF8**

670lbs/304kg

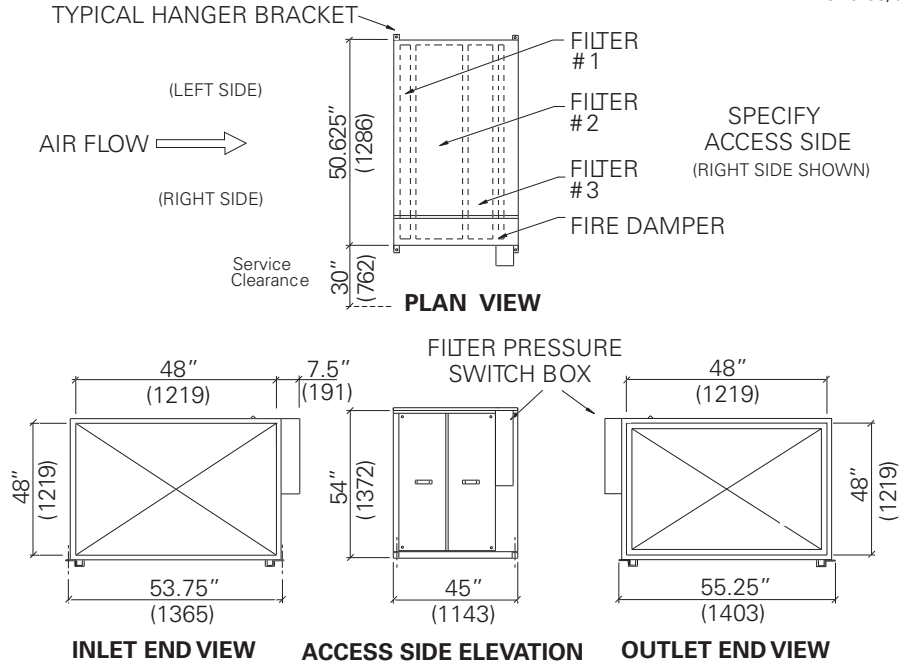

# ODOR CONTROL MODULE

**OC8**

400lbs/200kg

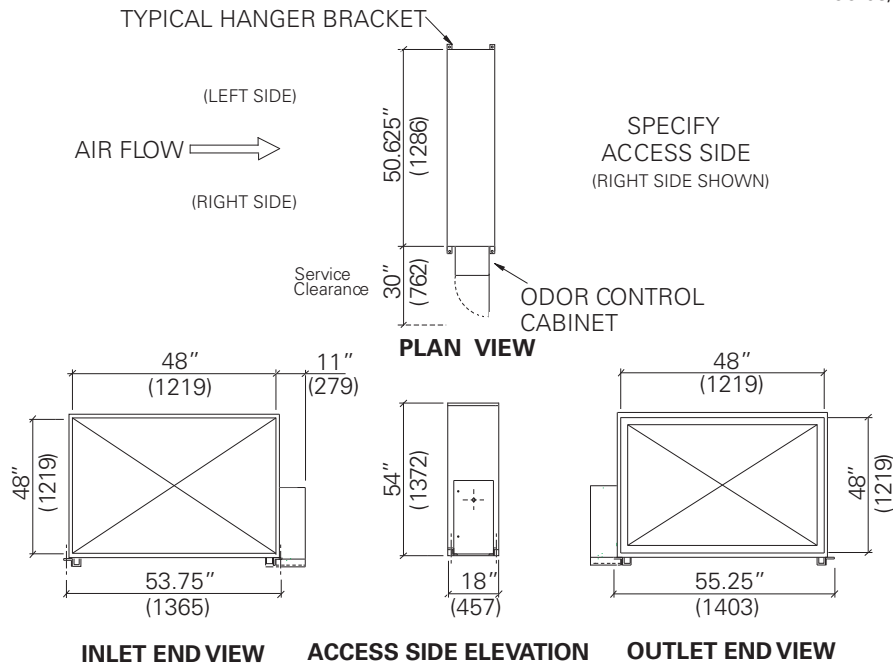

# FAN MODULE

## B8

1650lbs/750kg

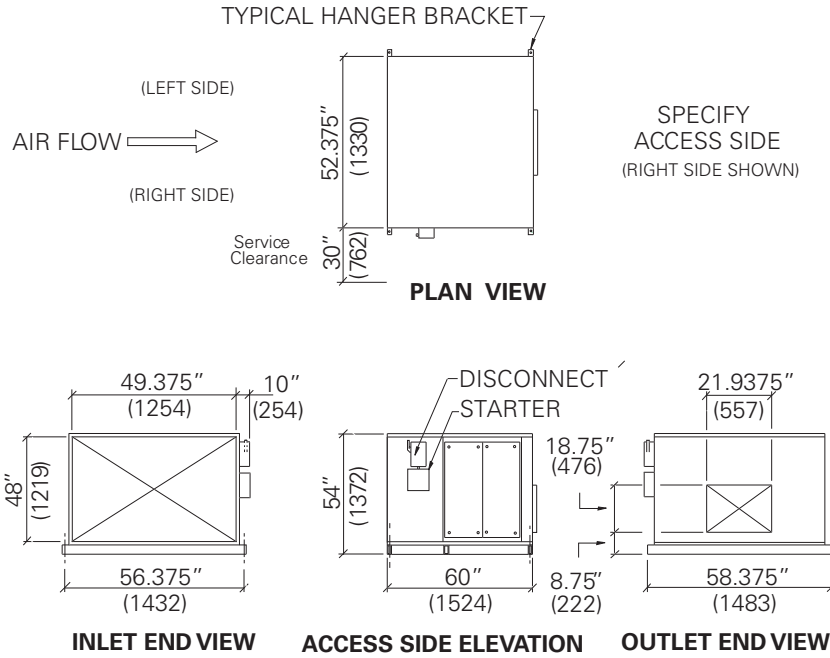

### EXTERNAL STATIC PRESSURE TO ECOLOAIR™ SYSTEM

MODEL NUMBER	1.0" ESP		1.5" ESP		2.0" ESP		2.5" ESP		3.0" ESP		3.5" ESP		4.0" ESP		4.5" ESP										
	RPM	BHP		RPM	BHP		RPM	BHP		RPM	BHP		RPM	BHP		RPM	BHP								
		HP	KW		HP	KW		HP	KW		HP	KW		HP	KW		HP	KW							
B8	6400	2162	79	5.7	2245	8.6	6.3	2325	9.3	6.8	2403	10.1	7.4	2479	10.9	7.9	2552	11.7	8.5	2624	12.5	9.1	2695	13.3	9.7
	7200	2229	9.1	6.6	2308	9.8	7.2	2384	10.6	7.8	2459	11.4	8.3	2533	12.3	8.9	2604	13.1	9.5	2674	13.9	10.2	2742	14.8	10.8
	8000	2305	10.4	7.6	2380	11.3	8.2	2453	12.1	8.8	2525	12.9	9.4	2595	13.8	10.1	2664	14.7	10.7	2731	15.6	11.4	2797	16.4	12.0

**Note:**

Fan calculations are based on interior/ducted blower arrangement. For exterior/free arrangement data, please contact the factory. Above stated for design guidelines only, actuals may vary. Please contact factory for project specific details.

## Consultant Specification

The EcoloAir™ Ecology System shall be a Model \_\_\_\_\_, as manufactured by Halton, supplied complete with Filter Module, Odor Control Module, Fan Module, and Control Panel. System mounting to be designed for; Interior/Exterior, Suspended/Floor/Roof. The system shall deliver \_\_\_\_\_ CFM (\_\_\_\_\_m3/s) at \_\_\_\_\_in.wg. (\_\_\_\_\_Pa) External Static Pressure (ESP). The Halton EcoloAir unit shall be ETL Listed.

### Filter Module

The unit casing shall be fully painted and be a double wall construction reinforced and braced for maximum rigidity. Inner walls shall be 16-gauge liquid tight welded and construction and outer walls shall be minimum 20-gauge steel. Filter sections to be insulated with 1.5" (38mm) insulation to the requirements of UL/ULC. The unit shall be complete with three stages of filtration.

- The first stage filter shall be a 2-inch deep pleated MERV 8 performance per ASHRAE 52.2 and classified to UL900 standard. The filter clean resistance shall not exceed 0.3 in.w.g.
- The second stage filter shall be a 15-inch deep Multi-Pocket MERV 14 performance per ASHRAE 52.2 and classified to UL900 standard. The filter clean resistance shall not exceed 0.95 in.w.g. and rated for at least 85% efficiency at 0.4 microns.
- The third stage filter shall be constructed from HEPA grade medium, 12-inch deep Mini-Pleat V-Bank MERV 16 performance per ASHRAE 52.2 and classified to UL900 standard. The filter clean resistance shall not exceed 0.6 in.w.g. with efficiency of at least 95% at 0.4 microns.

A UL/ULC Listed fire damper actuated by fusible link (165°F UL / 286°F ULC) shall be located at the outlet. This module to be complete with three pressure switches to monitor the condition of each of the three stages of filtration, and a fourth pressure switch to detect a lack of air pressure.

Hinged access doors shall be provided to allow easy access to the filters.

### Odor Control Module

The EcoloAir™ Odor Control Module shall consist of a housing and a self contained odor reducing system. The housing shall be fully painted and be constructed of 16 gauge (minimum) steel with all joints suitably reinforced and braced for rigidity. The "Ecolo Scentry™" liquid spray odor reducing system shall produce an atomized spray that permeates the filtered exhaust air to attack and neutralize airborne odors. The system housing shall be constructed of heavy steel with locking hinged access door and two security bolts. The system shall be complete with an adjustable spray nozzle, 5-gallon liquid reservoir. Timers mounted in the EcoloAir™ control panel to switch on, off and cycle control to provide for infinite adjustment.

### Fan Module

The fan housing shall be fully painted and be constructed from 16 gauge (minimum) steel with all joints suitably reinforced and braced for rigidity. The fan shall be AMCA rated be a DWDI (double width, double inlet), Class 2, backward inclined, with airfoil type blades and with non-overloading characteristics. The complete fan assembly is statically and dynamically balanced. The shaft is ground and polished steel. Bearings shall be pillow block type with lubrication nipples.

The company has a policy of continuous product development, therefore we reserve the right to modify design and specifications without notice.

Drives shall be V belt or grip notch with capacity 25% greater than motor horsepower. The fan and motor shall be mounted on a common base which is spring vibration isolated from the fan housing. A fire stat shall be located at the fan inlet to stop the fan on high air temperature. Hinged access doors shall be provided to allow easy access to fan and motor. Units to be complete with a \_\_\_\_\_HP (\_\_\_\_\_kW) \_\_\_\_\_ Volt \_\_\_\_\_ Phase \_\_\_\_\_Hz motor, motor starter complete with electrical overloads and electrical disconnect switch.

### Control Panel

The control panel shall be constructed from heavy gauge steel, be suitable for surface mounting, or remote mounting or recessed in the wall front locking screws. Controls shall be complete with touch screen. Display will indicate system operational status, condition of all three filter stages, percent (%) filter loaded for each stage, lack of air pressure, fire condition and odor reducing operation. Controls and interconnecting field wiring to be standard 120volt AC.

### ECOSystem

ECOSystem will be standard with all EcoloAir systems and will consist of 4 pressure transducers, a microprocessor and VFD. The 4 Pressure Transducers will monitor the pressure drop across each filter as well as pressure in the main duct to provide the status of each filter as a % loaded as well as notify the operator with an early warning of when the filters need to be replaced. On start up, the main pressure transducer is calibrated with the Capture Jet Testing and Balancing Ports to design airflow. The setting will be stored in the system memory and acts as the reference point for design exhaust. The Microprocessor will read the signals from the pressure transducer and controls the VFD to maintain constant airflow in the system regardless of the filter conditions. The V.F.D. (Variable Frequency Drive) will control the RPM of the fan module based on the signal received from the microprocessor.

## Modifications & Options

### GENERAL

- Weather Proof Insulation Package
- Rear Access Doors
- 24v Control Wiring
- New York City M.E.A. Package Available

### FILTER MODULE

- Fire Suppression System
- Extra Set of Filters
- Inlet Plenum
- Missing Filter Pressure Switch
- Air Proving Switch
- Magnehelic Gauge (Visual Monitors)

### ODOR CONTROL MODULE

- Cold Climate Insulation
- Extra Container of Odor Solution
- Low Level Odor Control Indicator Light

### FAN MODULE

- Acoustic Insulation Package
- Outlet Cowl
- Non Standard Voltage
- Single Phase Motor
- Internal Seismic Isolators
- Top Discharge
- Piggy Back Mount
- Variable Frequency Drive (VFD)

For more information, please contact your nearest Halton agency. To find it: [www.haltoncompany.com](http://www.haltoncompany.com)