

MBD Damper

Manual Balancing Damper

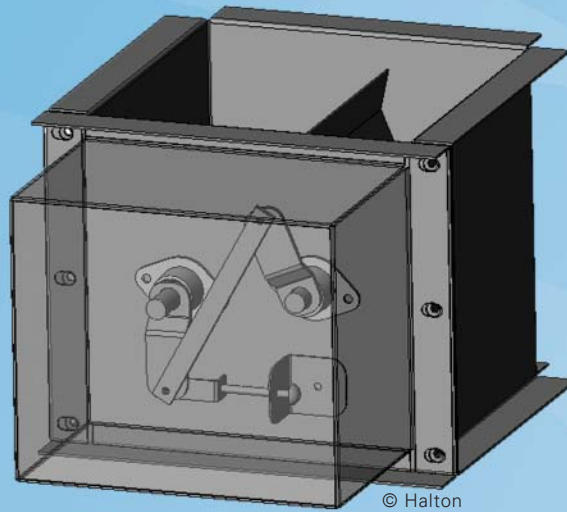

- Compact design - 8" high
- Pressure reading taken from TAB (testing & balancing) port, located within Halton hood
- Used on multiple hoods with common exhaust
- Does not accumulate grease like guillotine type dampers.

Specification

Furnish and install a Model MBD manual kitchen exhaust-balancing damper as manufactured by HALTON. The balancing damper shall bear the Underwriters Laboratories U.L. label per, U.L. listed range hood accessory per standard 710 and be fabricated in compliance with NFPA-96-2004,

The installation shall be in accordance with the manufacturer's recommendations and conform to NFPA-96 guidelines and all applicable local codes.

The size shall be as indicated on drawings and/or equipment schedule and match the exhaust collar size for the hood system.

The damper shall be adjustable to allow for balancing airflow based on pressure differential readings from integral T.A.B test and balance port in the Capture Jet hood. The damper outer casing shall be constructed of continuously welded 16ga. galvanized steel including the balancing blades. Optional construction is of 18ga. stainless steel. Adjustment of the parallel dampers (in open position) will be achieved by manually turning the locking adjustment bracket until the desired pressure reading is achieved.

Model MBD is to be used on Capture Jet style hoods, models KVE, KVC, KVL, KVW, KVR and KVO



MODEL: MBD

EXHAUST VOLUME DAMPER

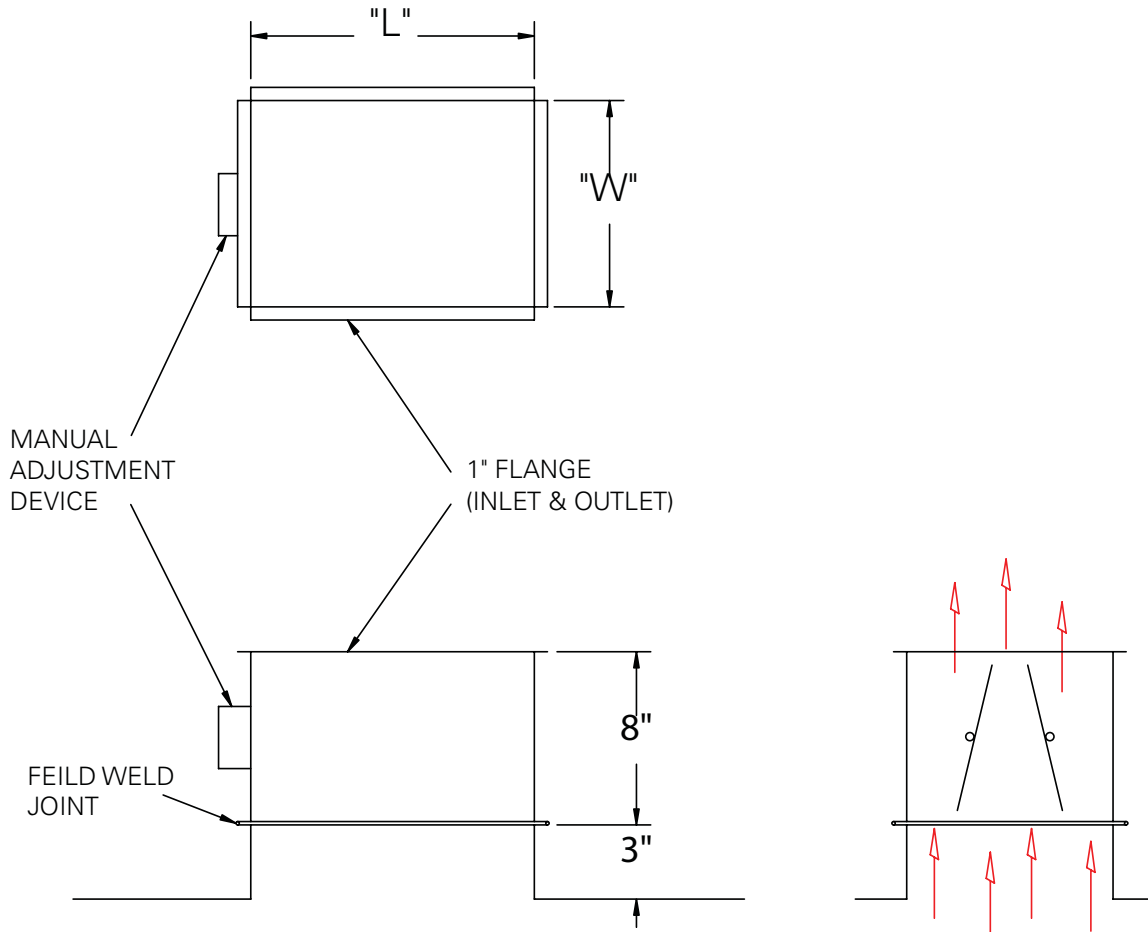

TAG	"L"	"W"	QUANTITY
-	-	-	1
-	-	-	1
-	-	-	1
-	-	-	1
-	-	-	1
-	-	-	1

MATERIAL:
 FRAME- 16GA CONT. WELDED
 OUTER SHELL AND
 ADJUSTABLE BLADES