

Halton

Model LED Fixture Light-Emitting Diode

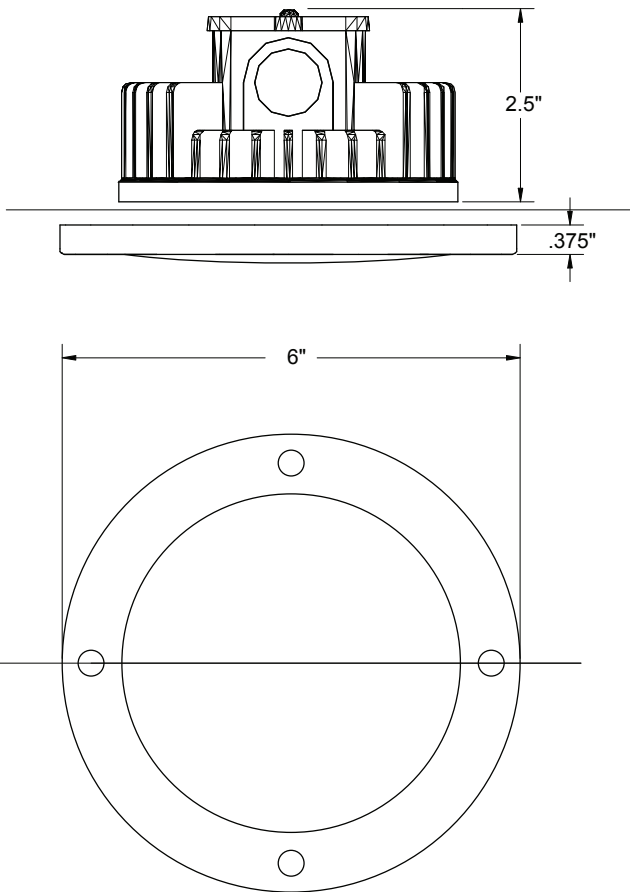

Specification

Provide and install Halton Patent Pending LED light fixture with the following certifications U.L., CSA, NSF and CE for use in grease exhaust hoods in quantity sufficient to provide 50 foot candles at the cooking surface when hood is mounted 84" A.F.F. Halton LED light fixture is complete with die cast aluminum junction box with integral fins for natural heat dissipation. Input voltage of 24VDC with a power consumption not to exceed 20 watts. The housing encases 24 factory installed LED light emitters with a brightness of 1000 lumens. Halton's LED lights lamp body is stainless steel ring with a high temperature silicone seal. Junction box to accept standard 1/2" NPT fitting. Fixture shall come complete with integral power supply with an input voltage of 108VAC – 305VAC and input frequency of 50/60 Hz. Input current rating shall be 0.57A @ 120VAC. Fixture shall contain no mercury or lead.



Light-Emitting Diode

Features and Benefits:

- Saves up to 80% of the energy of an equivalent incandescent bulb
- Can be retrofitted to any Capture Jet® hood with incandescent globe type lights
- When installed on 36" centers, provides 50 foot-candles to typical cooking surface for exhaust hoods mounted at 84" A.F.F.
- Grease proof, waterproof and heat proof construction
- Suitable for dry and wet locations
- Mercury free design
- Life expectancy is approximately 50,000 hours, which is 50 times longer than typical incandescent 100W bulbs
- No labor for changing bulbs (approximately every 55 days for incandescent type)
- Warm white (3500 K) or Cool White (6500 K) color available

Operating Cost Savings

LED vs Incandescent at 18 hours per day operating

$$18 \text{ hours} \times 365 \text{ days} \times 100\text{W (Incandescent)} \times 6 \\ = 3942\text{kWh} / \text{year} / \text{Incandescent Lamp}$$

$$18 \text{ hours} \times 365 \text{ days} \times 20\text{W (LED)} \times 4 \\ = 527\text{kWh} / \text{year} / \text{LED Fixture}$$

3415 kWh Savings x \$0.14 / kWh

$$= \underline{\underline{\$478.10 \text{ per } 10' \text{ of hood per year}}}$$

*Required to meet 50 foot candles.



Continuous improvement is a Halton policy, therefore specifications and designs are subject to change without notice.



Halton Company
101 Industrial Drive, Scottsville, KY 42164
Tel: 270-237-5600 Fax: 270-237-5700
www.haltoncompany.com

Halton Indoor Climate Systems, Ltd.
1021 Brevik Place, Mississauga, ON L4W 3R7
Tel: 905-624-0301 Fax: 905-624-5547
www.haltoncanada.com