



CEILING DAMPERS

Nailor
Industries Inc.

Contents

Page No.

| | |
|---|------------|
| Product Overview | H3 |
| Ceiling Damper Basics | H5 |
| Fire-Rated Packages | H6 |
| Square/Rectangular Ceiling Dampers | |
| Model 0716 • Butterfly Type | H7 |
| Model 0716-4 • Low Profile Butterfly Type | H8 |
| Model 0714 • Single Blade | H8 |
| Round Ceiling Dampers | |
| Model 0722 • Round | H9 |
| Model 0722-SE /LE • Round • Short/Long Extensions | H9 |
| Adjustable Volume Control Ceiling Dampers | |
| Model 0716A • Square/Rectangular | H11 |
| Model 0716-4A • Low Profile Square/Rectangular | H12 |
| Model 0722A • Round | H12 |
| Model 0722A-SE /LE • Round With Extension | H13 |
| Low Profile Curtain Type Ceiling Dampers | |
| Model 0720 • Square/Rectangular | H14 |
| Thermal Blankets | |
| Model 0725 • For Round Neck | H16 |
| Model 0726 • For Square Neck | H16 |
| Wood Truss Ceiling Dampers | |
| Model 0755 • Grille Mount • Top Inlet | H17 |
| Model 0755A • Grille Mount • Top Inlet • Adjustable | H17 |
| Model 0756 • Grille Mount • Side Inlet • Steel Plenum | H19 |
| Model 0756D • Ducted • Side Inlet • Steel Plenum | H20 |
| Model 0757 • Grille Mount • Side Inlet | H21 |
| Model 0757D • Ducted • Side Inlet | H22 |
| Model 0758 • Register Box • Side Inlet | H23 |
| Model 0759 • Register Box • Side Inlet • Insulated | H24 |
| Model 0760 • Register Box • 45° Inlet | H24 |
| Model 0761 • Register Box • Top Inlet | H25 |
| Model 0762 • Register Box • Top Inlet • Insulated | H25 |

H

CEILING DAMPERS

GENERAL PRODUCT OVERVIEW

For over thirty years, Nailor Industries has been committed to the development of life safety products such as the 0700 Series Ceiling Dampers. This commitment has helped foster industry standards, as well as provide worry free fire protection solutions that benefit today's building designers, owners and occupants. Approved for use in lieu of hinged door type dampers in UL floor/ceiling or roof/ceiling assemblies, the Nailor 0700 Series provides a fire and heat barrier that has been tested and qualified to the most exacting standards. For square and rectangular applications, Model 0716 is available with standard blade construction or low profile blades, Model 0716-4. Round duct applications are covered by Model 0722. Nailor's new Model 0720 features a spring loaded curtain design that maximizes free area while providing a low overall profile. Other Series 0700 particulars such as the Adjustable Fusible Link option, ideal for balancing at the grille/diffuser, and Models 0755 thru 0762, suitable for use in wood truss ceiling assemblies, have been developed to meet specific requirements in today's building systems.

MODELS 0716, 0716-4, 0714 AND 0722 CEILING RADIATION DAMPER FOR SQUARE, RECTANGULAR OR ROUND DUCT

Nailor ceiling dampers, or ceiling radiation dampers as they are commonly called, are designed to function as a fire and heat barrier in air duct openings penetrating fire resistive membrane ceilings. Models 0716, 0716-4 and 0714 are for use in square or rectangular applications and Model 0722 is for use in round applications, in lieu of hinged door type dampers in any UL floor/ceiling or roof/ceiling assembly with up to a 3 hour fire resistance rating where air ducts are allowed.

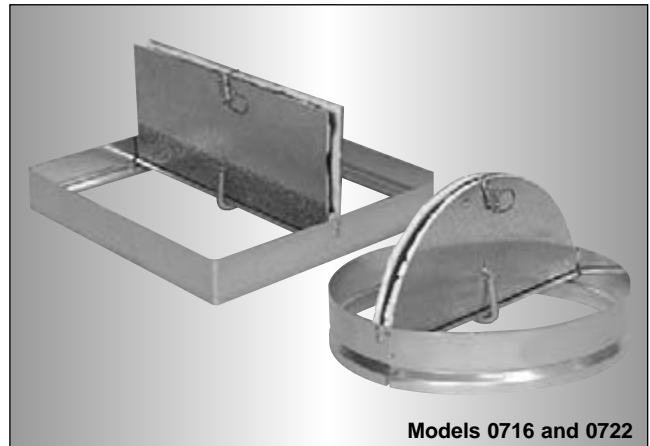

Models 0716 and 0722



Models 0722A and 0716A

MODELS 0716A, 0716-4A AND 0722A CEILING RADIATION DAMPER • ADJUSTABLE FOR SQUARE, RECTANGULAR OR ROUND DUCT

Nailor ceiling dampers with **adjustable volume control** option are designed to function as a fire and heat barrier in air duct openings penetrating fire resistive membrane ceilings. The adjustable volume control mechanism allows the blades to be adjusted for balancing of airflow through the diffuser. Under fire conditions the fusible link will close the damper, regardless of volume setting. Models 0716A and 0716-4A are for use in square or rectangular applications and Models 0722A is for use in round applications, in lieu of hinged door type dampers in any UL floor/ceiling or roof/ceiling assembly with up to a 3 hour fire resistance rating where air ducts are allowed.

MODEL 0720 CEILING RADIATION DAMPER FOR SQUARE OR RECTANGULAR DUCT

The Nailor Model 0720 ceiling radiation damper, which functions as a fire and heat barrier in air duct openings that penetrate fire resistive membrane ceilings, is for use in lieu of hinged door type dampers in any UL floor/ceiling assembly with up to a 3 hour fire resistance rating where air ducts are permitted. Model 0720 features a specially designed 'pull across' insulated curtain that provides a low overall profile, making it ideal for use in applications where the available duct drop height for installation is limited. The compact curtain design also maximizes free area in the open position.

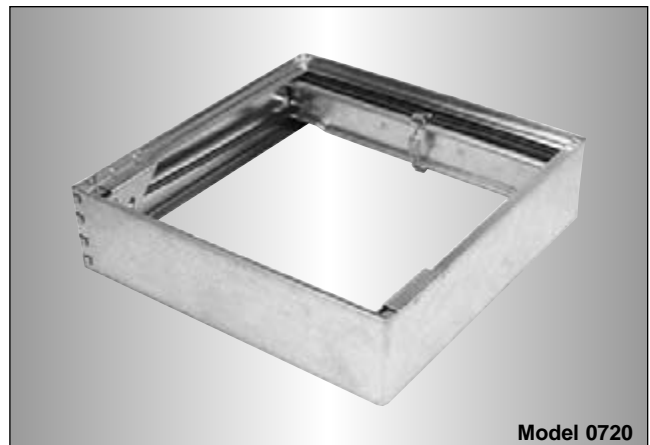

Model 0720

GENERAL PRODUCT OVERVIEW

MODELS 0725/0726 THERMAL INSULATING BLANKET

Nailor Models 0725 and 0726 Thermal Blankets are designed to insulate the exposed back pan area of a steel ceiling diffuser that may be used in UL Classified floor/ceiling or roof/ceiling assemblies with up to a 3 hour rating. The insulation protects the floor/roof structure above from the intense heat that radiates through the diffuser pan during fire conditions. A thermal blanket is used in conjunction with a ceiling radiation damper that protects the neck opening of the diffuser, to provide complete protection of the opening in the ceiling membrane. Model 0725 thermal blanket is for use with 0722 ceiling damper models in round neck applications. Model 0726 thermal blanket is for use with 0714, 0716 and 0720 ceiling damper models in square neck applications.

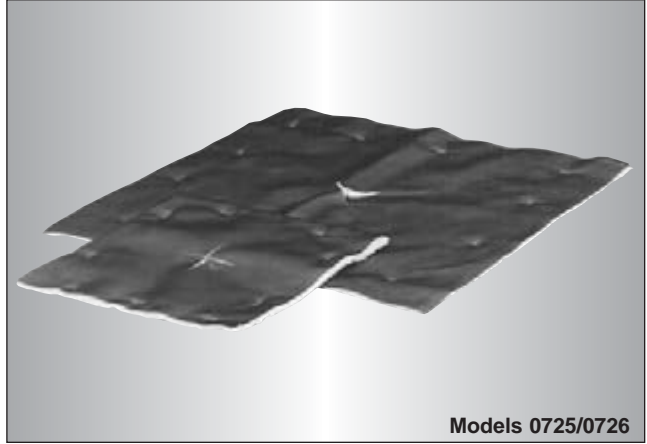

Models 0725/0726

H

CEILING DAMPERS



Models 0755 and 0756

MODEL SERIES 0755, 0756 AND 0757 CEILING RADIATION DAMPER FOR WOOD TRUSS CEILING ASSEMBLIES

Nailor Models 0755, 0756 and 0757 Ceiling Radiation Dampers have been designed and tested for simple installation in specific UL design wood truss ceiling assemblies. They are UL Classified for use in 1 hour rated UL floor/ceiling design numbers L550, L562, L574 and L579 and roof/ceiling design numbers P531, P538 and P545. Model 0755 ships complete with thermal blanket and top inlet round duct connection. Model Series 0756 features a factory sheet metal plenum with side duct connection collars. Model Series 0757 is designed for side duct connection collars.

MODELS 0758, 0759, 0760, 0761 AND 0762 CEILING RADIATION DAMPER/REGISTER BOX FOR WOOD TRUSS CEILING ASSEMBLIES

Models 0758 thru 0762 register boxes with integral ceiling dampers have been specifically designed and tested to provide protection and simple installation in specific UL design wood truss ceiling assemblies. Model 0758 features a side inlet; Model 0759 features a side inlet and is insulated. Model 0760 is insulated with a 45° inlet. Model 0761 features a top inlet; Model 0762 is insulated with a top inlet.

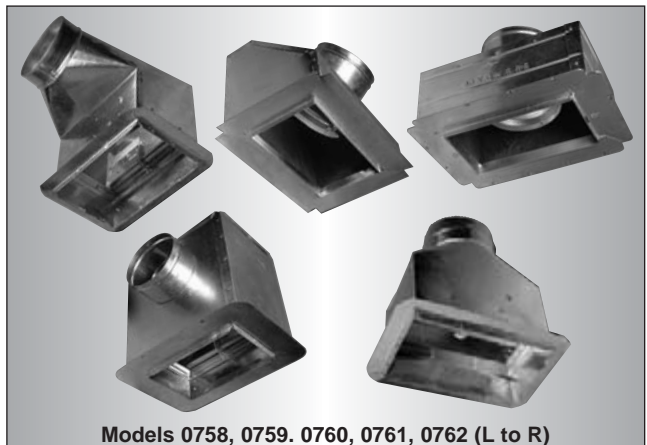

Models 0758, 0759, 0760, 0761, 0762 (L to R)

CEILING DAMPER BASICS:

Definition of a Ceiling Damper (quoted from NFPA Standard 90A):

“A device installed to limit radiant heat transfer through an air outlet or air inlet opening in the ceiling of a floor-or roof-ceiling assembly having not less than a 1 hour fire resistance rating.”

What is the difference between a Ceiling Damper and a standard Fire Damper?

In order to comprehend the difference we must first understand some of the theory behind fire-rated ceilings. A fire-rated ceiling's primary function is to protect the structure above it from excessive heat and potential subsequent collapse by providing a fire and heat retardant barrier between the fire area and the structural floor above.

Without any openings in the fire-rated ceiling, it would perform as designed by limiting the transfer of heat through the floor above it.

Problems arise when we pierce the protective ceiling with big holes to accommodate environmental control devices such as grilles and diffusers. To close these openings should a fire occur, devices called Ceiling Dampers (also commonly called radiation dampers or fire stop flaps) have been developed. If the openings were to remain unobstructed during a fire, generated heat would tend to rapidly flow through in concentration due to a 'funnel effect' created at the openings as the hot combustion gases expand and rise. This

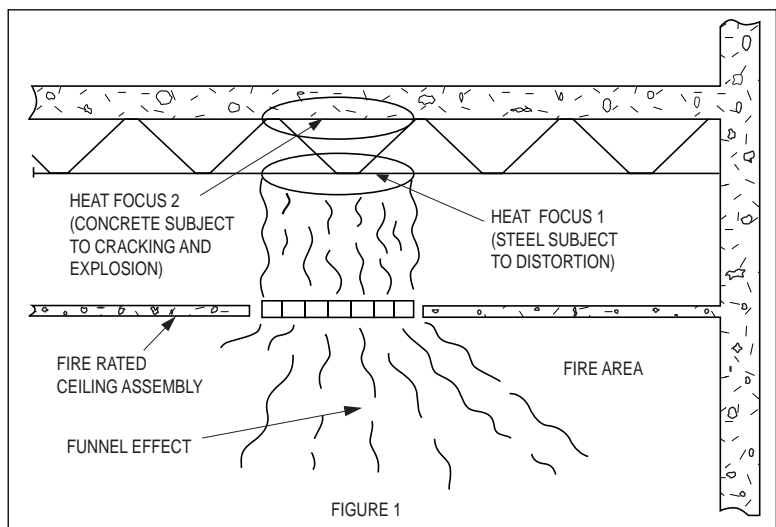

focuses the intense heat into the structure area directly above the openings, potentially causing severe structural damage (See Figure 1). Ceiling dampers are specifically designed to protect against this phenomenon by firstly, closing the opening to stop any air flow and secondly, by reducing the amount of heat that is conducted and, most importantly, radiated through the device. This is most important, as a regular fire damper although fine for stopping flame and migratory air flow, is virtually transparent to heat and therefore ineffective in this application.

- Ceiling Dampers are tested by Underwriter's Laboratories to the strict criteria of UL 555C, Safety Standard for Ceiling Dampers which includes tests for:
 1. Fire Endurance
 2. Closing Reliability
 3. Dust Loading
 4. Salt-Spray Exposure
 5. Spring Closing Force (if applicable)
- Ceiling Dampers are not assigned hourly ratings themselves, but rather are listed for use as a component in an assembly designated for use in fire resistance assemblies having specific hourly ratings.
- All Nailor Ceiling Dampers are classified (Category CABS) for use in any UL floor/ceiling or roof/ceiling restrained or unrestrained type assembly with up to a 3 hour fire resistance rating.

FIRE RATED PACKAGES:

LOOKING TO SAVE TIME, MONEY AND HASSLES?

As an alternative to assembling separate components,







LOOK TO NAILOR FIRE-RATED DIFFUSER AND GRILLE PACKAGES.

As a manufacturer of both **Air Distribution Products** (grilles, diffusers, etc.) and **Air Control Products** (fire dampers, control dampers, etc.) Nailor can offer **Fire-Rated Packages** as an alternative to assembling separate components from potential separate manufacturers. Nailor is unique, as we can supply **Fire-Rated Packages** at a competitive price, all manufactured at the same facilities for fast lead times and guaranteed Nailor quality . . . no out-sourcing like other manufacturers.

FEATURES/BENEFITS:

- Complete package, including ceiling damper, grille/diffuser etc., factory assembled to save on installation time (and money!) and ensure proper assembly.
- Wide variety of quality Nailor diffuser and grille styles to choose from.
- UL and ULC Classified assemblies for use in restrained or unrestrained ceilings incorporating an exposed grid with up to a 3 hour rating.
- Surface Mount package available for hard ceilings.
- Approved for use with Class 0 or 1 Flexible Duct.
- Ductless Return Air grilles can be installed with no connecting ductwork, ideal for use when ceiling space is used for return air.

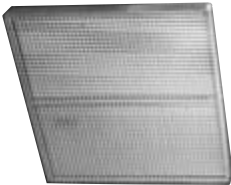
SOME OF THE NAILOR FIRE-RATED PACKAGES AVAILABLE:

| | | |
|---|--|---|
|  <p>RNS DIFFUSER SERIES 4000</p> |  <p>PERFORATED FACE SERIES 4000</p> |  <p>MODULAR CORE SERIES 7500 FRD</p> |
|  <p>PLENUM SLOT SERIES 5500</p> |  <p>EGGCRATE OR PERFORATED DUCTLESS RETURNS SERIES 4100</p> |  <p>LOUVER FACE DUCTLESS RETURNS SERIES 4100</p> |

SEE THE NAILOR AIR DISTRIBUTION PRODUCTS CATALOG FOR A COMPLETE SELECTION OF FIRE-RATED PACKAGES.

CEILING DAMPERS • ROUND/SQUARE/RECTANGULAR Nailor

- UL 555C CLASSIFIED
- FOR SQUARE, RECTANGULAR OR ROUND DUCT

MODELS: 0716
0716-4
0714
0722

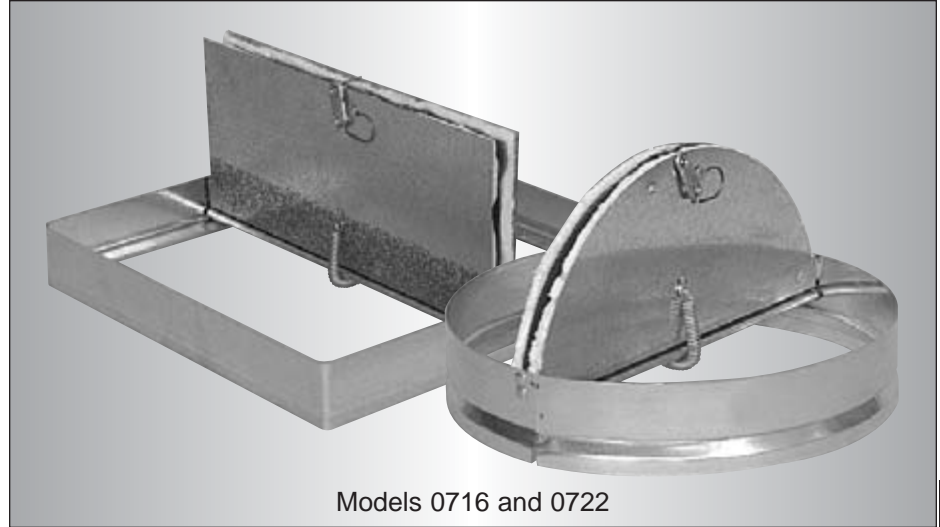

Models 0716 and 0722

Nailor ceiling dampers, or ceiling radiation dampers as they are commonly called, are designed to function as a fire and heat barrier in air duct openings penetrating fire resistive membrane ceilings. Models 0716, 0716-4 and 0714 are for use in square or rectangular applications and Model 0722 is for use in round applications, in lieu of hinged door type dampers in any UL floor/ceiling or roof/ceiling assembly with up to a 3 hour fire resistance rating where air ducts are allowed.

QUALIFICATIONS:

- UL 555C Classified Ceiling Damper (File # R9660).
- California State Fire Marshal: Ceiling Damper Listing No. 3226-0935:102.
- City of New York Board of Standards and Appeals. Cal. No. 460-88-SA.
- Meets NFPA 90A, BOCA, SBCCI, IBC and UBC requirements.
- CAN4/ULC-S112-2 Ceiling Fire Stop Flap Assemblies.
- Meets NBC of Canada requirements.

MODEL: 0716 (SQUARE OR RECTANGULAR)

UL MAXIMUM SIZE: 24" x 24" (610 x 610)
UL MINIMUM SIZE: 6" x 3" (150 x 75)

CONSTRUCTION:

1. U.L. Listed fusible link, 212°F (100°C), standard.
2. Blades: galvanized steel.
3. Insulation; Non-asbestos UL Classified on units over 80 sq. in. (516 sq. cm) finished size, standard. Not required on smaller units.
4. Roll-formed frame: galvanized steel.
5. Duct drop (by others).

OPTIONS:

1. 165°F (74°C) U.L. Listed fusible link.

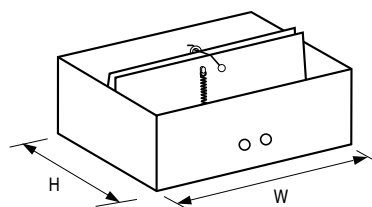
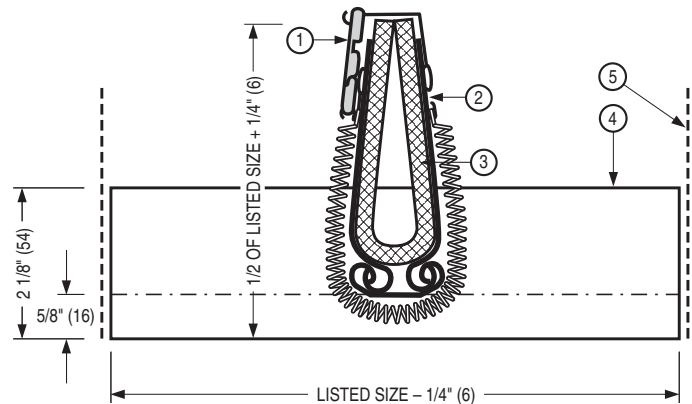

SKETCH 1
(H = 6" (152) or more)

Units manufactured with blade length on dimension (W) except where short dimension (H) is less than 6" (152).
(See Sketch 1 above)

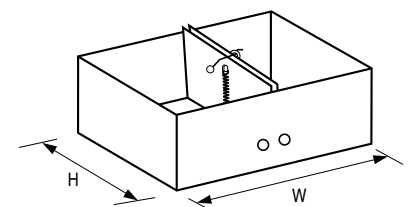

SKETCH 2
(H = less than 6" (152))

If short dimension (H) is less than 6" (152), units are manufactured with blade length on short dimension.
(See Sketch 2 above)

H

CEILING DAMPERS

MODEL: 0716-4 LOW PROFILE (SQUARE OR RECTANGULAR)

MODEL 0716-4 provides a low profile, dual set of blades design, ideal for installation in tight places.

UL MAXIMUM SIZE: 24" x 24" (610 x 610)
 UL MINIMUM SIZE: 12" x 6" (300 x 150)

CONSTRUCTION:

1. U.L. Listed fusible link, 212°F (100°C), standard.
2. Blades: galvanized steel.
3. Non-asbestos UL Classified insulation on units over 80 sq. in. (516 sq. cm) finished size, standard. Not required on smaller units.
4. Roll-formed frame: galvanized steel.
5. Duct drop (by others).

OPTIONS:

1. 165°F (74°C) U.L. Listed fusible link.

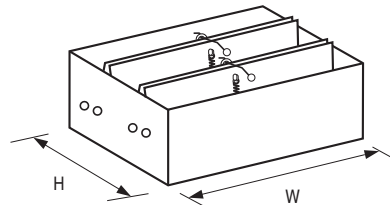
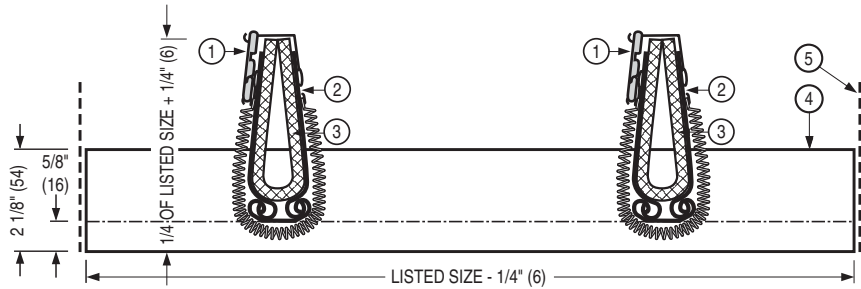

SKETCH 1

(H = 12" (305) or more)

Units manufactured with blade length on dimension (W) except where short dimension (H) is less than 12" (305).
 (See Sketch 1 above)

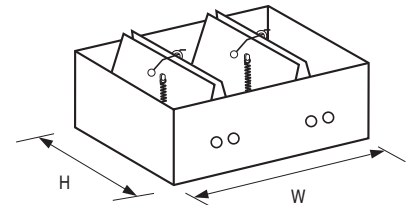

SKETCH 2

(H = less than 12" (305))

If short dimension (H) is less than 12" (305), units are manufactured with blade length on short dimension.
 (See Sketch 2 above)

MODEL: 0714 SINGLE BLADE (SQUARE OR RECTANGULAR)

Model 0714's single blade design provides maximum free area and no obstruction to airflow when open.

UL MAXIMUM SIZE: 24" x 24" (610 x 610)
 UL MINIMUM SIZE: 4" x 4" (102 x 102)

CONSTRUCTION:

1. U.L. Listed fusible link, 212°F (100°C), standard.
2. Blades: galvanized steel.
3. Non-asbestos UL Classified insulation on units over 80 sq. in. (516 sq. cm) finished size, standard. Not required on smaller units.
4. Roll-formed frame: galvanized steel.
5. Hinge.
6. Duct drop (by others).

OPTIONS:

1. 165°F (74°C) U.L. Listed fusible link.

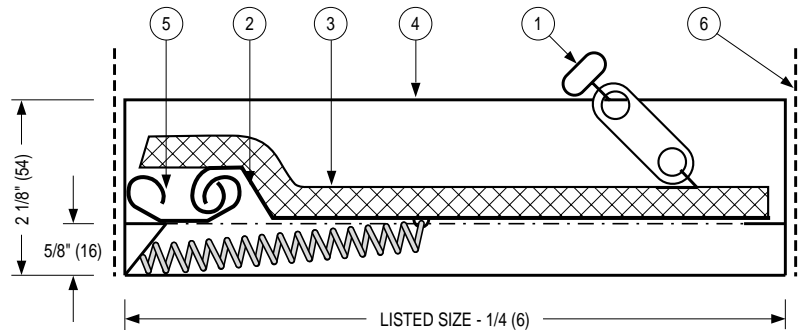

CLOSED POSITION

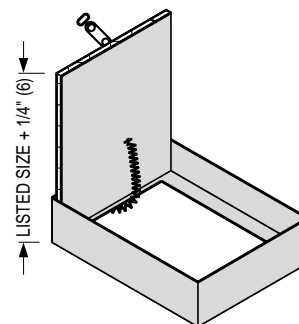

OPEN POSITION

CEILING DAMPERS • ROUND/SQUARE/RECTANGULAR

MODEL: 0722 (ROUND)

UL MAXIMUM SIZE: 24" (610) dia.
UL MINIMUM SIZE: 4" (100) dia.

CONSTRUCTION:

1. U.L. Listed fusible link, 212°F (100°C), standard.
2. Blades: galvanized steel.
3. Insulation; Non-asbestos UL Classified on units 12 in. (305) dia. and larger. Not required on smaller units.
4. Roll-formed frame: galvanized steel.
5. Duct drop (by others).

OPTIONS:

1. 165°F (74°C) U.L. Listed fusible link.

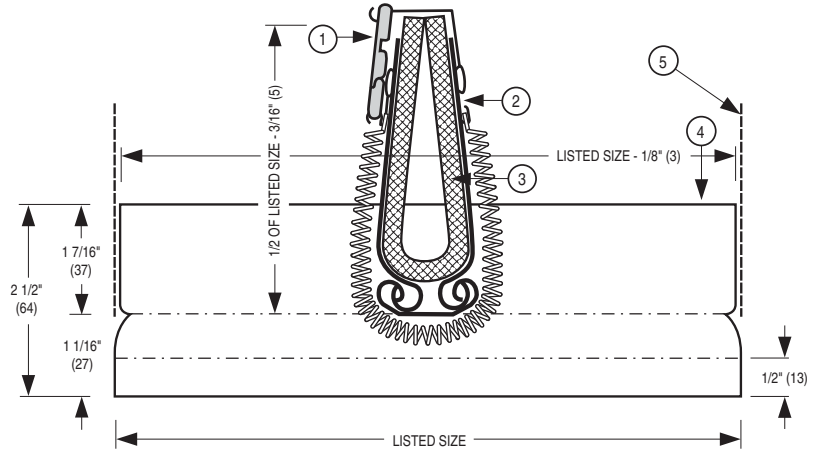
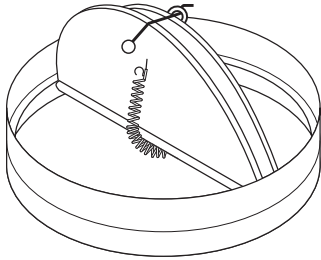

UNIT SIZE 4" (102) DIA. ONLY.

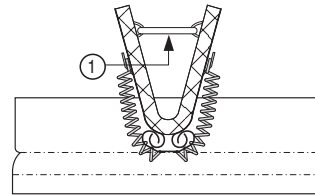

H

CEILING DAMPERS

MODELS: 0722-SE (ROUND) SHORT TOP EXTENSION 0722-LE (ROUND) LONG TOP EXTENSION

The extension collar on Models 0722-SE and 0722-LE minimizes the risk of interference with blade closure in flexible duct installations and helps ensure even airflow into the diffuser neck for optimum performance.

UL MAXIMUM SIZE: 24" (610) dia.
UL MINIMUM SIZE: 4" (100) dia.

CONSTRUCTION:

1. U.L. Listed fusible link, 212°F (100°C), standard.
2. Blades: galvanized steel.
3. Insulation; Non-asbestos UL Classified on units 12 in. (305) dia. and larger. Not required on smaller units.
4. Roll-formed frame: galvanized steel.
5. Top extension.

OPTIONS:

1. 165°F (74°C) U.L. Listed fusible link.

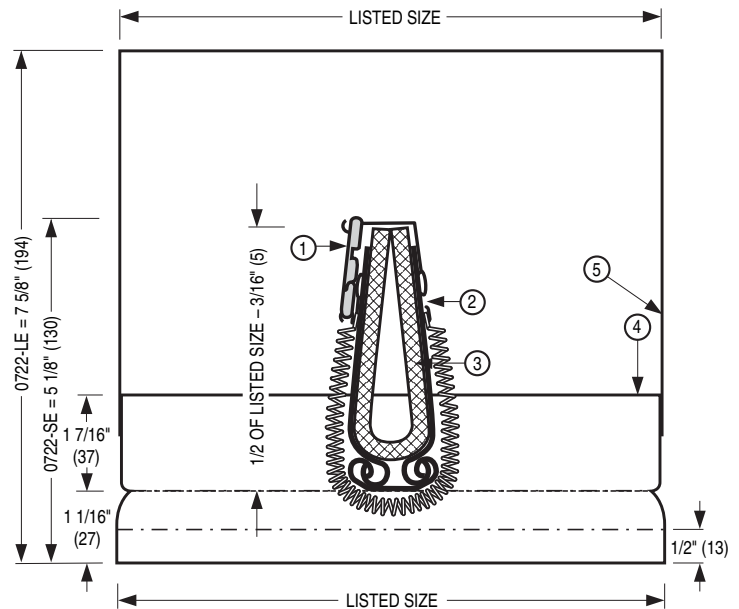
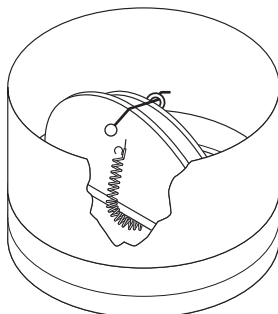

UNIT SIZE 4" (102) DIA. ONLY.

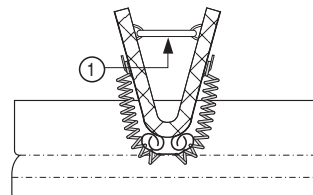

HOW TO SPECIFY OR TO ORDER

MODELS: 0716/0716-4/0722/0722-SE/LE

SUGGESTED SPECIFICATION:

Provide and install, as shown on plans and/or schedules, ceiling fire dampers as manufactured by Nailor Industries meeting the following criteria: Ceiling fire dampers shall be UL Classified for use in all restrained and unrestrained UL Listed ceiling assemblies with fire resistance ratings of 3 hours or less. Dampers shall be tested and manufactured in accordance with UL 555C Standard for Ceiling Dampers and shall bear a UL label identifying same. Each ceiling damper shall be held open with a 212°F (100°C) UL Listed fusible link (or specifier to select 165°F (74°C)), and shall be of size and configuration as indicated. Square or rectangular applications shall utilize Nailor Model 0716 as standard. Round applications shall utilize Nailor Model 0722 as standard. Ceiling dampers shall ship with and be installed in accordance with manufacturers UL installation instructions. Information submitted for approval shall include same UL installation instructions. Standard of acceptance: Nailor Industries Models 0716/0722.

For SE/LE top extensions, add the following: Model 0722 round ceiling dampers shall be provided with long top extensions Model 0722-LE, or short top extensions Model 0722-SE, as deemed suitable by space above ceiling, to ensure flex duct does not interfere with blade closure.

HOW TO ORDER:

Order by model number and size, then list optional fusible link (if desired).

| | OPTION CODE | DESCRIPTION |
|----------------------|-------------|-------------------------------------|
| FUSIBLE LINK: | 165 | 165°F (74°C) UL Listed Fusible Link |

H

CEILING DAMPERS

- **UL 555C CLASSIFIED**
- **ADJUSTABLE VOLUME CONTROL**
- **FOR SQUARE, RECTANGULAR OR ROUND DUCT**

**MODELS: 0716A
0716-4A
0722A**



Models 0722A and 0716A

Nailor ceiling dampers, or ceiling radiation dampers as they are commonly called, with **Adjustable Volume Control** option, are designed to function as a fire and heat barrier in air duct openings penetrating fire resistive membrane ceilings. The adjustable volume control mechanism allows the blades to be adjusted for balancing of airflow through the diffuser. Under fire conditions the fusible link will close the damper, regardless of volume setting. Models 0716A and 0716-4A are for use in square or rectangular applications and Models 0722A is for use in round applications, in lieu of hinged door type dampers in any UL floor/ceiling or roof/ceiling assembly with up to a 3 hour fire resistance rating where air ducts are allowed.

QUALIFICATIONS:

- UL 555C Classified Ceiling Damper (File # R9660).
- California State Fire Marshal: Fire Damper listing No. 3226-0935:102.
- City of New York Board of Standards and Appeals. Cal. No. 460-88-SA.
- Meets NFPA 90A, BOCA, SBCCI, IBC and UBC requirements.
- CAN4/ULC-S112-2 Ceiling Fire Stop Flap Assemblies.
- Meets NBC of Canada requirements.

MODEL: 0716A ADJUSTABLE (SQUARE OR RECTANGULAR)

UL MAXIMUM SIZE: 16" x 16" (406 x 406)
UL MINIMUM SIZE: 6" x 3" (150 x 75)

CONSTRUCTION:

1. U.L. Listed fusible link, 212°F (100°C), standard.
2. Blades: galvanized steel.
3. Insulation; Non-asbestos UL Classified on units over 80 sq. in. (516) finished size. Not required on smaller units.
4. Roll-formed frame: galvanized steel.
5. Adjustable fusible link assembly permits volume control.
6. Duct drop (by others).

OPTIONS:

1. 165°F (74°C) U.L. Listed fusible link.

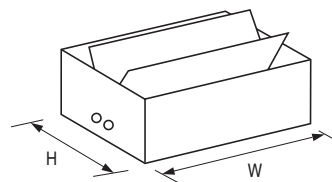
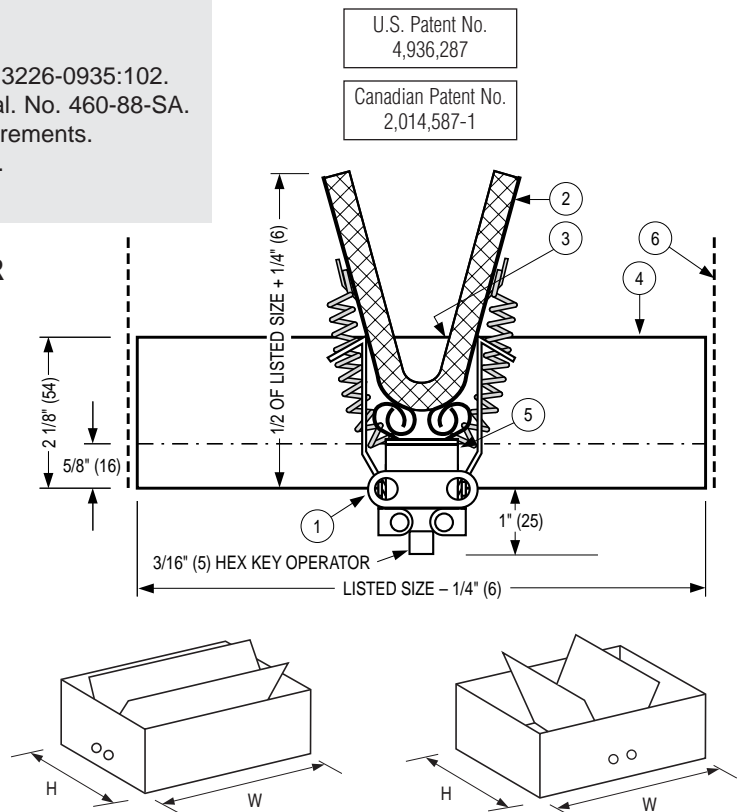

SKETCH 1

(H = 6" (150) or more)

Units manufactured with blade length on dimension (W) except where short dimension (H) is less than 6" (150). (See Sketch 1 above)

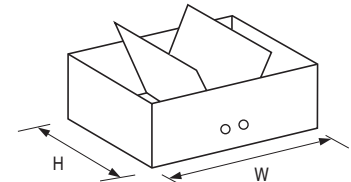

SKETCH 2

(H = less than 6" (150))

If short dimension (H) is less than 6" (150), units are manufactured with blade length on short dimension. (See Sketch 2 above)

MODEL: 0716-4A LOW PROFILE; ADJUSTABLE (SQUARE OR RECTANGULAR)

MODEL 0716-4A provides a low profile, dual set of adjustable blades design, ideal for installation in tight places.

UL MAXIMUM SIZE: 24" x 24" (610 x 610)
 UL MINIMUM SIZE: 12" x 6" (300 x 150)

CONSTRUCTION:

1. U.L. Listed fusible link, 212°F (100°C), standard.
2. Blades: galvanized steel is standard.
3. Insulation; Non-asbestos UL Classified on units over 80 sq. in. (516) finished size. Not required on smaller units.
4. Roll-formed frame: galvanized steel is standard.
5. Adjustable fusible link assembly permits volume control.
6. Duct drop (by others).

OPTIONS:

1. 165°F (74°C) U.L. Listed fusible link.

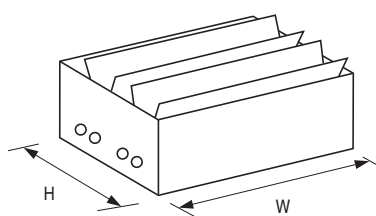
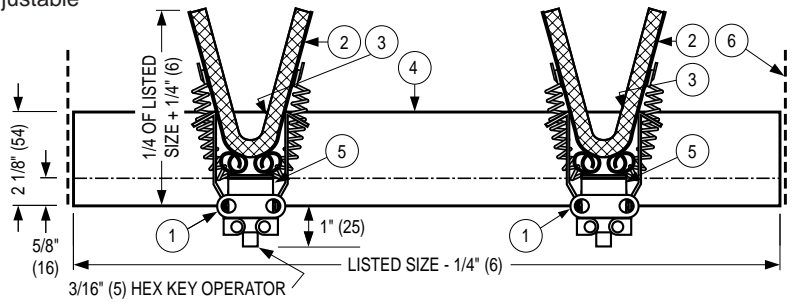

SKETCH 1

(H = 12" (300) or more)

Units manufactured with blade length on dimension (W) except where short dimension (H) is less than 12" (300). (See Sketch 1 above)

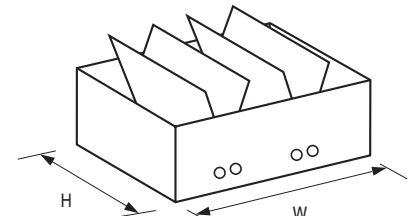

SKETCH 2

(H = less than 12" (300))

If short dimension (H) is less than 12" (300), units are manufactured with blade length on short dimension. (See Sketch 2 above)

MODEL: 0722A ADJUSTABLE (ROUND)

UL MAXIMUM SIZE: 16" (406) dia.
 UL MINIMUM SIZE: 5" (127) dia.

CONSTRUCTION:

1. U.L. Listed fusible link, 212°F (100°C), standard.
2. Blades: galvanized steel.
3. Insulation; Non-asbestos UL Classified on units 12" (305) dia. and larger, standard. Not required on smaller units.
4. Roll-formed frame: galvanized steel.
5. Adjustable fusible link assembly permits volume control.
6. Duct drop (by others).

OPTIONS:

1. 165°F (74°C) U.L. Listed fusible link.

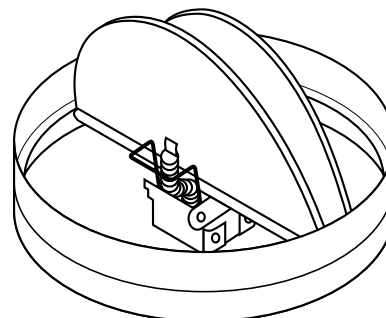
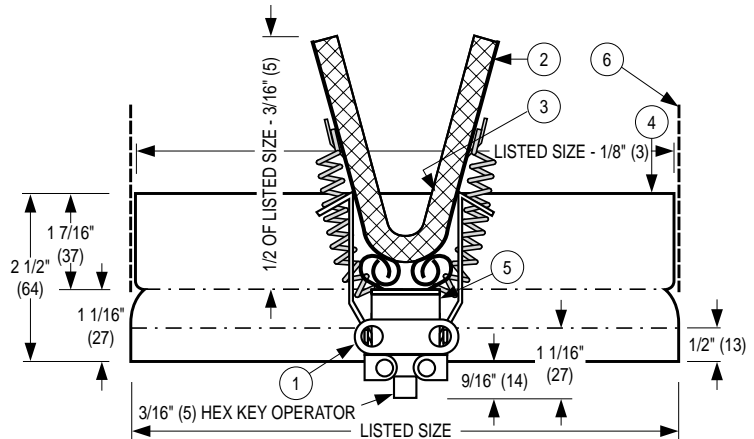

MODELS: 0722A-SE ADJUSTABLE (ROUND) SHORT EXTENSION 0722A-LE ADJUSTABLE (ROUND) LONG EXTENSION

The extension collar on Models 0722A-SE and 0722A-LE minimizes the risk of interference with blade closure in flexible duct installations and helps ensure even airflow into the diffuser neck for optimum performance. These models incorporate a mechanism to adjust the opening of the blades for balancing airflow through the ceiling diffuser.

UL MAXIMUM SIZE: 16" (406) dia.
UL MINIMUM SIZE: 5" (127) dia.

CONSTRUCTION:

1. U.L. Listed fusible link, 212°F (100°C), standard.
2. Blades: 22 ga. (0.85) G60 galvanized steel.
3. Insulation: Non-asbestos UL Classified on units 12" (305) dia. and larger, standard. Not required on smaller units.
4. Frame: Roll-formed 22 ga. (0.85) G60 galvanized steel.
5. Adjustable fusible link assembly permits volume control.
6. Top extension.

OPTIONS:

1. 165°F (74°C) U.L. Listed fusible link.

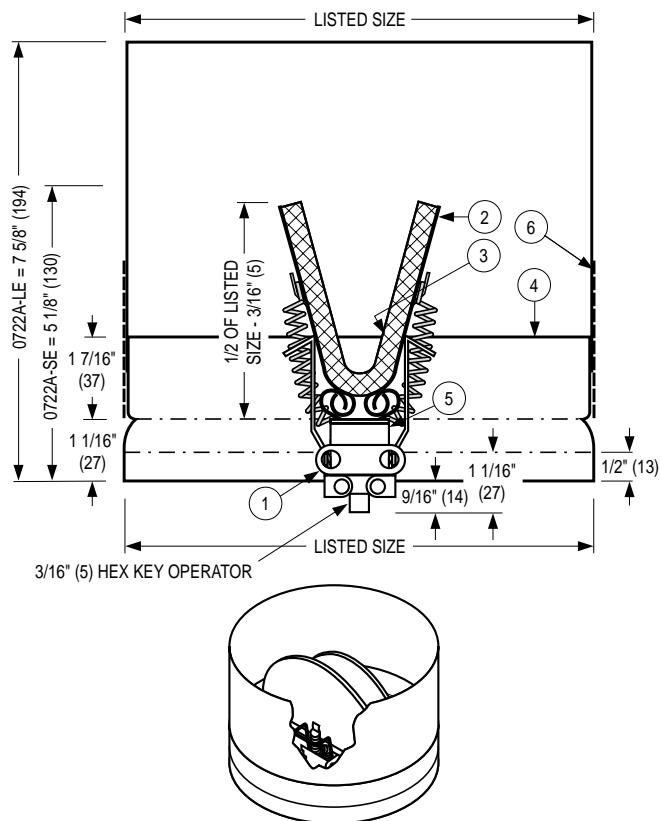

H
CEILING DAMPERS

HOW TO SPECIFY OR TO ORDER

MODELS: 0716A / 716-4A / 0722A / 0722A-SE / 0722A-LE

SUGGESTED SPECIFICATION:

Provide and install, as shown on plans and/or schedules, ceiling fire dampers with adjustable volume control as manufactured by Nailor Industries meeting the following criteria: Ceiling dampers shall be UL Classified for use in all restrained and unrestrained UL Listed ceiling assemblies with fire resistance ratings of 3 hours or less. Dampers shall be tested and manufactured in accordance with UL 555C Standard for Ceiling Dampers and shall bear a UL label identifying same. Each ceiling damper shall be held open with a 212°F (100°C) UL Listed adjustable fusible link (or specifier to select 165°F (74°C)), and shall be of size and configuration as indicated. Square or rectangular applications shall utilize Nailor Model 0716A as standard. Round applications shall utilize Nailor Model 0722A as standard. Ceiling dampers shall ship with and be installed in accordance with manufacturers UL installation instructions. Information submitted for approval shall include same UL installation instructions. Standard of acceptance: Nailor Industries Models 0716A / 0722A.

For SE/LE top extensions, add the following: Model 0722A round dampers shall be provided with long top extensions Model 0722A-LE, or short top extensions Model 0722A-SE, as deemed suitable by space above ceiling, to ensure flex duct does not interfere with blade closure.

HOW TO ORDER:

Order by model number and size, then list optional fusible link (if desired).

| | OPTION CODE | DESCRIPTION |
|----------------------|-------------|-------------------------------------|
| FUSIBLE LINK: | 165 | 165°F (74°C) UL Listed Fusible Link |

- UL 555C CLASSIFIED
- CURTAIN TYPE CEILING RADIATION DAMPER
- LOW PROFILE
- FOR SQUARE OR RECTANGULAR DUCT

MODEL: 0720



H

CEILING DAMPERS

The Nailor Model 0720 ceiling radiation damper, which functions as a fire and heat barrier in air duct openings that penetrate fire resistive membrane ceilings, is for use in lieu of hinged door type dampers in any UL floor/ceiling assembly with up to a 3 hour fire resistance rating where air ducts are permitted. Model 0720 features a specially designed 'pull across' insulated curtain that provides a low overall profile, making it ideal for use in applications where the available duct drop height for installation is limited. The compact curtain design also maximizes free area in the open position.

QUALIFICATIONS:

- UL 555C Classified Ceiling Damper (File # R9660).
- California State Fire Marshal: Ceiling Damper Listing No. 3226-0935:102.
- City of New York MEA No. 366-03-M.
- Meets NFPA 90A, BOCA, SBCCI, IBC and UBC requirements.
- CAN4-S112.2 Ceiling Fire Stop Flap Assemblies.
- Meets NBC of Canada requirements.

UL MAXIMUM SIZE: 18" x 18" (457 x 457)
 UL MINIMUM SIZE: 6" W x 4" H (152 x 102)

CONSTRUCTION:

1. UL listed fusible link, 212°F (100°C) standard.
2. Blades: 22 ga. (.034) G60 coating galvanized steel.
3. Curtain Insulation: Non-asbestos UL Classified.
4. Frame: Roll-formed 22 ga. (.034) G60 coating galvanized steel.
5. Stainless steel negator closure spring.
6. Curtain blade locking ramp.

OPTIONS:

1. 165°F (74°C) U.L. Listed fusible link.

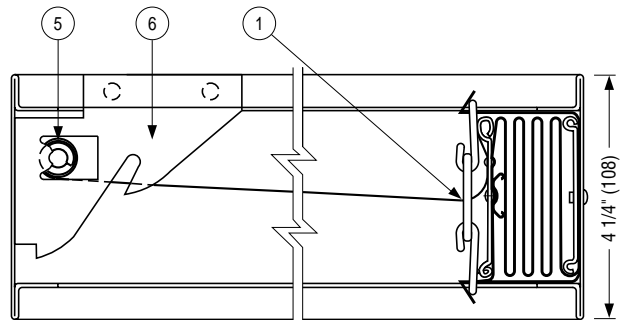
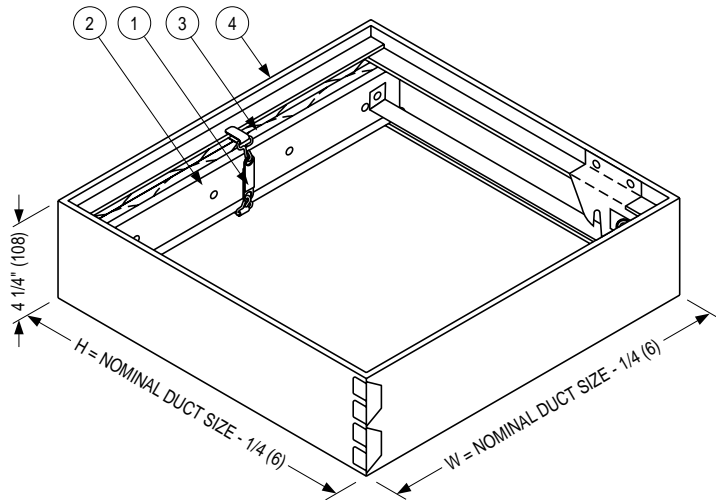

HOW TO SPECIFY OR TO ORDER

MODEL: 0720

SUGGESTED SPECIFICATION:

Provide and install, as shown on plans and/or schedules, low profile ceiling fire dampers as manufactured by Nailor Industries meeting the following criteria: Low profile ceiling fire dampers shall be UL Classified for use in all restrained and unrestrained UL Listed ceiling assemblies with fire resistance ratings of 3 hours or less. Dampers shall be tested and manufactured in accordance with UL 555C Standard for Ceiling Dampers and shall bear a UL label identifying same. Curtain shall be manufactured from non-asbestos UL Classified insulation with protective covering to prevent erosion. Each ceiling damper shall be held open with a 212°F (100°C) UL Listed fusible link (or specifier to select 165°F (74°C)) and shall be of sizes indicated. Ceiling dampers shall ship with and be installed in accordance with manufacturers UL installation instructions. Information submitted for approval shall include same UL installation instructions. Standard of acceptance: Nailor Industries Model 0720.

HOW TO ORDER:

Order by model number and size, then list optional fusible link (if desired).

| | OPTION CODE | DESCRIPTION |
|----------------------|-------------|-------------------------------------|
| FUSIBLE LINK: | 165 | 165°F (74°C) UL Listed Fusible Link |

- THERMAL INSULATING BLANKET
- UL CLASSIFIED
- ACCESSORY FOR 0714, 0716, 0720, 0722
- FOR ROUND AND SQUARE NECK DIFFUSERS

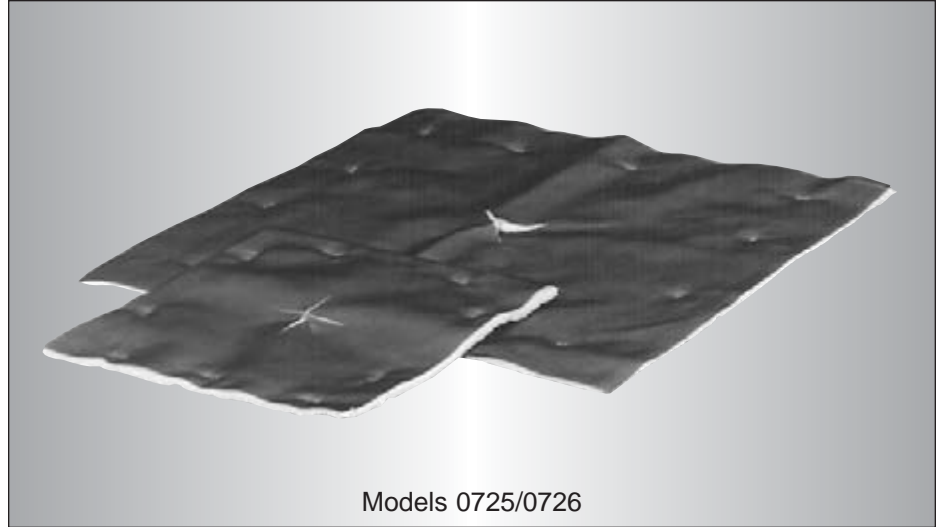

**MODELS: 0725
0726**

CEILING DAMPERS

Nailor Models 0725 and 0726 Thermal Blankets are designed to insulate the exposed back pan area of a steel ceiling diffuser that may be used in UL Classified floor/ceiling or roof/ceiling assemblies with up to a 3 hour rating. The insulation protects the floor/roof structure above from the intense heat that radiates through the diffuser pan during fire conditions. A thermal blanket is used in conjunction with a ceiling radiation damper that protects the neck opening of the diffuser, to provide complete protection of the opening in the ceiling membrane. Model 0725 thermal blanket is for use with 0722 ceiling damper models in round neck applications. Model 0726 thermal blanket is for use with 0714, 0716 and 0720 ceiling damper models in square neck applications.

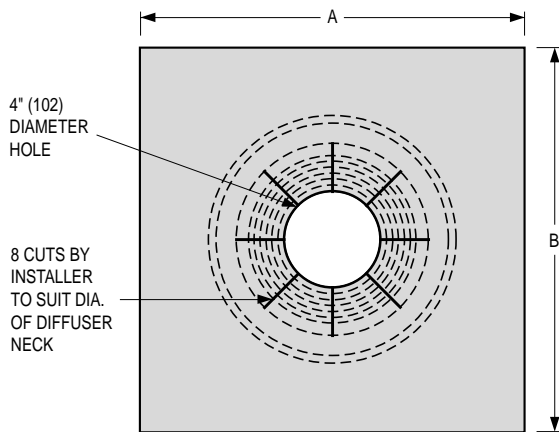

Model 0725: For round applications

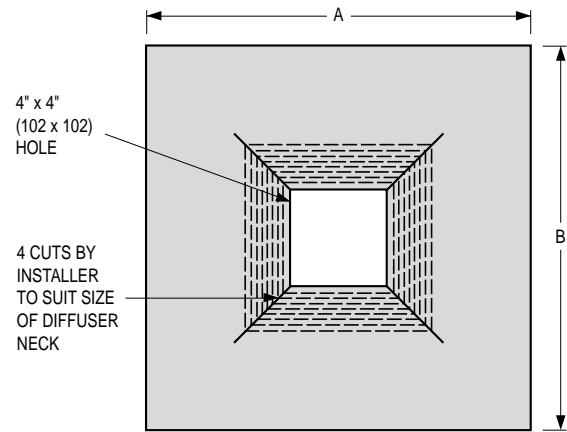

Model 0726: For square applications

| Ceiling Diffuser Nominal Size | | | Blanket Size A x B | |
|-------------------------------|-----------|----------------|-----------------------------|-----------|
| Imperial Modules | | Metric Modules | Imperial and Metric Modules | |
| inches | mm | mm | inches | mm |
| 12 x 12 | 305 x 305 | 300 x 300 | 16 x 16 | 406 x 406 |
| 24 x 12 | 610 x 305 | 600 x 300 | 28 x 16 | 711 x 406 |
| 24 x 24 | 610 x 610 | 600 x 600 | 28 x 28 | 711 x 711 |

NOTES:

1. Insulation: Non-asbestos UL Classified.
2. For use on the back of steel lay-in diffusers up to 24" x 24" (610 x 610) nominal face size.
3. Installer to make cuts, as shown, to the desired size of the diffuser neck.

- FOR WOOD TRUSS CEILING ASSEMBLIES
UL DESIGNS L550/L562/
L574/L579 & P531/P538/P545
- TOP INLET
- OPTIONAL ADJUSTABLE VOLUME CONTROL

MODELS:

- 0755** **STANDARD UNIT**
- 0755A** **WITH ADJUSTABLE VOLUME CONTROL**

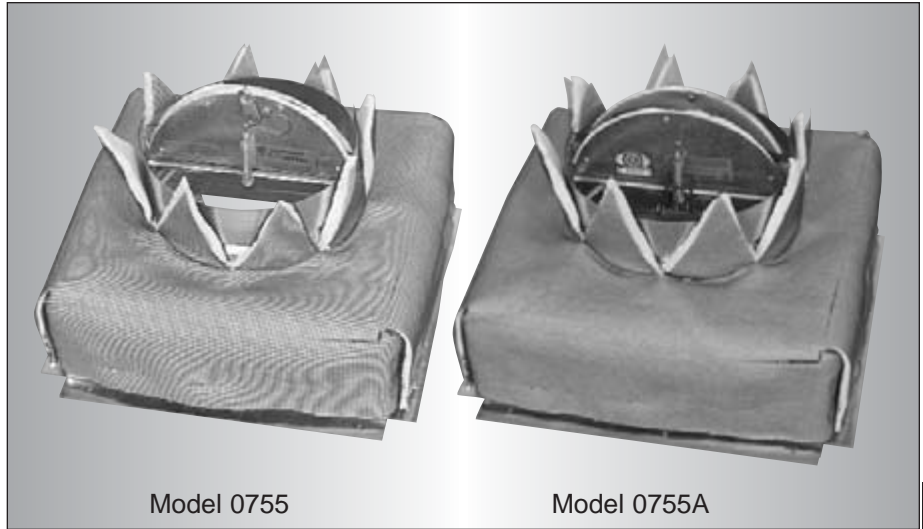

Nailor Models 0755 and 0755A ceiling radiation dampers have been designed and tested for simple installation in specific UL design wood truss ceiling assemblies. They are UL Classified for use in 1 hour rated UL floor/ceiling design numbers L550/L562/L574/L579 and roof/ceiling design numbers P531/P538/P545. Each unit ships complete with thermal blanket and top inlet round duct connection to accept UL Classified Class 0 or 1 flex duct. Be sure to check available ceiling plenum depth to ensure sufficient clearance for attachment and curving of flex duct without damper interference. Model 0755A includes an adjustable volume control mechanism that allows for balancing at the diffuser.

QUALIFICATIONS:

- UL 263 Classified Ceiling Radiation Damper (File # R9660). Category CABS.
- California State Fire Marshal: Ceiling Damper Listing No. 3226-0935:114.
- City of New York MEA No. 366-03-M.
- 1 hour rated for use in UL floor/ceiling design #'s L550/L562/L574/L579 and roof/ceiling design #'s P531/P538/P545 (Similar in construction to designs L521/L546 & P522 respectively).
- Meets NFPA 90A requirements.

STANDARD CONSTRUCTION:

1. UL listed fusible link, 212°F (100°C) standard.
2. Blades: galvanized steel.
3. Ceramic fiber insulation.
4. Roll-formed frame: galvanized steel.
5. Flexible air duct (UL Classified Class 0 or 1) (by others).
6. Optional adjustable volume control (Model 0755A).
7. Plaster flange.
8. Thermal blanket.
9. Steel grille/diffuser (optional or by others).

OPTIONS:

1. 165°F (74°C) or 286°F (141°C) UL listed fusible link.
2. Installation Support Angles. 26" (660) long:
 - ISA 2 @ 3/4" x 3/4" x 16 ga. (19 x 19 x 1.6).
 - ISB 2 @ 1 1/2" x 1 1/2" x 22 ga. (38 x 38 x 0.85).

Maximum Opening Size: 144 sq. inches (929 cm²).

Maximum Square Size: 12" x 12" (305 x 305)

Minimum Square Size: 6" x 6" (152 x 152)

Available Duct Connection Size: 4" through 10" (102 – 254) dia.

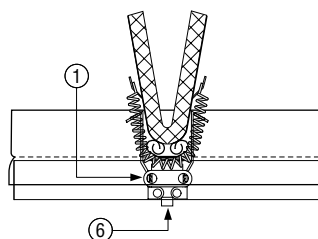
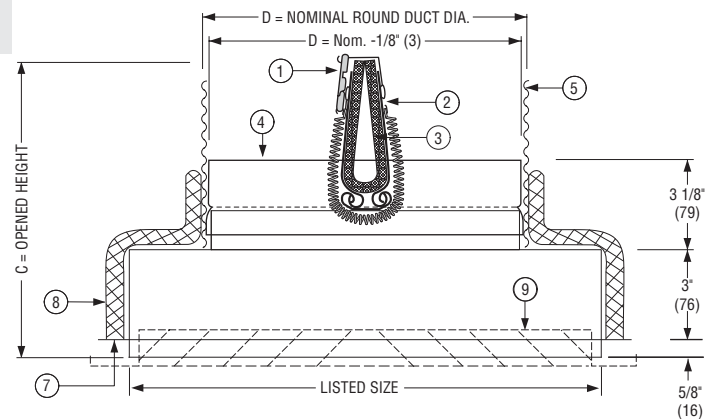

0755A Damper Design

| Nominal Duct Size | Opened Height C |
|-------------------|-----------------|
| 4" (102) | 6 1/2" (165) |
| 5" (127) | 7" (178) |
| 6" (152) | 7 1/2" (191) |
| 7" (178) | 8" (203) |
| 8" (203) | 8 1/2" (216) |
| 10" (254) | 9 1/2" (241) |

HOW TO SPECIFY OR TO ORDER

MODELS: 0755/0755A

SUGGESTED SPECIFICATION:

Provide and install, as shown on plans and/or schedules, ceiling fire dampers as manufactured by Nailor Industries, qualified for use in specific wood truss ceiling assemblies with 1 hour fire rating. Dampers shall be tested and manufactured in accordance with UL 555C Standard for Ceiling Dampers and UL 263 Standard for Fire Tests of Building Construction and Materials, and shall bear a UL label. Each ceiling damper shall be held open with a 212°F (100°C) UL Listed fusible link (or specifier to select 165°F (74°C)), and shall be sizes as indicated. Damper assembly shall incorporate a thermal blanket for complete protection of transition housing. All ceiling dampers shall ship with and be installed in accordance with manufacturers UL installation instructions. Information submitted for approval shall include same UL installation instructions. Standard of acceptance: Nailor Industries Model 0755.

For Adjustable Volume Control option, Model 0755A, add the following:

Ceiling dampers shall incorporate an adjustable volume control mechanism for balancing of airflow at the diffuser. Standard of acceptance: Nailor Industries Model 0755A.

HOW TO ORDER:

Order by model number and square or rectangular opening size (maximum 144 sq. in. (929 cm²)). Select duct connection diameter, then list any options (if desired).

Note: Duct connection diameter must not exceed opening dimension. Maximum diameter is 10" \varnothing (254).

ie: 8" x 8" (203 x 203) opening size may have up to 8" \varnothing (203) maximum duct connection size.

| | OPTION CODE | DESCRIPTION |
|----------------------|-------------|---|
| FUSIBLE LINK: | 165 | 165°F (74°C) UL Listed Fusible Link |
| | 286 | 286°F (141°C) UL Listed Fusible Link |
| ACCESSORIES: | ISA | Installation Support Angles (One Pair) 3/4" x 3/4" x 16 ga. x 26" long (19 x 19 x 1.6 x 660). |
| | ISB | Installation Support Angles (One Pair) 1 1/2" x 1 1/2" x 22 ga. x 26" long (38 x 38 x 0.85 x 660). |

- FOR WOOD TRUSS CEILING ASSEMBLIES
UL DESIGNS L550/L562/
L574/L579 & P531/P538/P545
- SIDE INLET
- STEEL PLENUM

MODELS:

- 0756** GRILLE MOUNT WITH STEEL PLENUM
- 0756D** DUCTED WITH STEEL PLENUM



Nailor Models 0756 and 0756D ceiling radiation dampers with steel plenums have been designed and tested for simple installation in specific wood truss ceiling assemblies. They are UL Classified for use in 1 hour rated UL floor/ceiling design numbers L550/L562/L574/L579 and roof/ceiling design numbers P531/P538/P545. Model 0756 is designed to accommodate a steel grille/diffuser in applications where the plenum terminates at the ceiling. Model 0756D is designed for installation in supply ductwork take-off from an AHU where it penetrates the ceiling and provides a multiple-outlet plenum to feed 0756 grille/diffuser assemblies. The 0756D damper sleeve extends below the ceiling, suitable for ducted connection. Both models feature side connection collars to accept UL Classified Class 0 or 1 flex duct.

QUALIFICATIONS:

- UL 263 Classified Ceiling Radiation Damper. Category CABS. (File # R9660).
- California State Fire Marshal: Ceiling Damper Listing No. 3226-0935:114.
- City of New York MEA No. 366-03-M.
- 1 hour rated for use in UL floor/ceiling design #'s L550/L562/L574/L579 and roof/ceiling design #'s P531/P538/P545 (Similar in construction to designs L521/L546 & P522 respectively).
- Meets NFPA 90A requirements.

MODEL: 0756

STANDARD CONSTRUCTION:

1. UL listed fusible link, 212°F (100°C) standard.
2. Blades: 22 ga. (0.85) G60 roll-formed galvanized steel.
3. Blade Insulation: Non-asbestos UL Classified.
4. Damper frame: 22 ga. (0.85) G60 galvanized steel.
5. Steel plenum/sub-frame: 26 ga. (0.55) min. with round connection collar(s). Maximum of three.
6. UL Classified Class 0 or I Flexible Air Duct connection by others.
7. 5/8" (16) plaster flange.
8. Model 0756. Steel grille/diffuser (by Nailor or others). Bottom of damper sub-frame is flush with ceiling. Standard depth for grille clearance is 2 1/2" (64).

OPTIONS:

1. 165°F (74°C) UL listed fusible link.
2. Installation Support Angles. 26" (660) long.
 - ISA 2 @ 3/4" x 3/4" x 16 ga. (19 x 19 x 1.6).
 - ISB 2 @ 1 1/2" x 1 1/2" x 22 ga. (38 x 38 x 0.85).

Minimum Size: 6" W x 4" H (152 x 102)

Maximum Size:

Model 0756 16" W x 12" H (406 x 305)

Model 0756D 18" W x 18" H (457 x 457)

Available Duct Connection Size: 4" through 10" (102 – 254) dia.

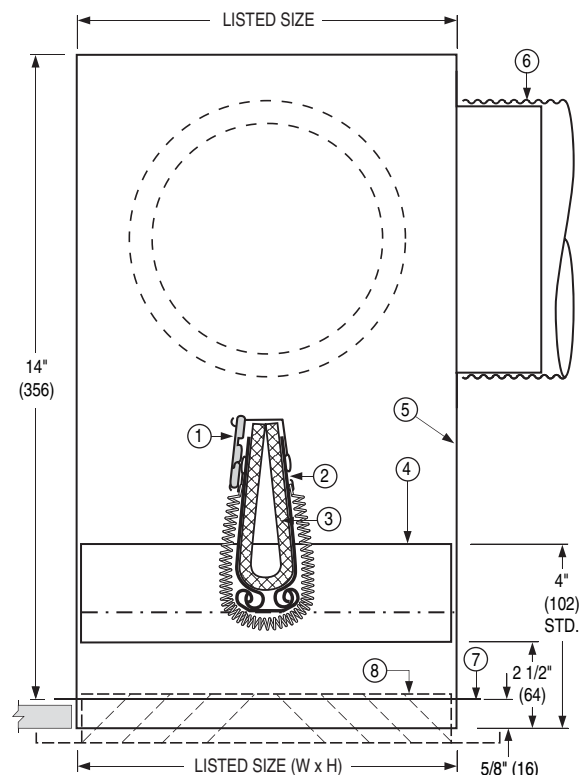

MODEL 0756D

STANDARD CONSTRUCTION:

1. UL listed fusible link, 212°F (100°C) standard.
2. Blades: 22 ga. (0.85) G60 roll-formed galvanized steel.
3. Blade Insulation: Non-asbestos UL Classified.
4. Damper frame: 22 ga. (0.85) G60 galvanized steel.
5. Steel plenum/sub-frame: 26 ga. (0.55) min. with round connection collar(s). Maximum of three.
6. UL Classified Class 0 or I Flexible Air Duct connection by others.
7. Plaster flange.
8. Damper sleeve is extended below ceiling for ducted connection. Damper is mounted in sub-frame to be flush with ceiling when installed.

OPTIONS:

1. Non-standard temp. UL listed fusible link.
 - 165°F (74°C)
2. Installation Support Angles. 26" (660) long.
 - ISA 2 @ 3/4" x 3/4" x 16 ga. (19 x 19 x 1.6) or
 - ISB 2 @ 1 1/2" x 1 1/2" x 22 ga. (38 x 38 x 0.85).

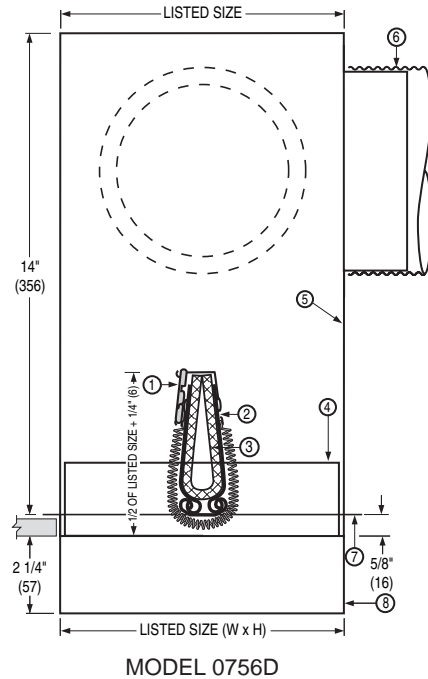

H

CEILING DAMPERS

HOW TO SPECIFY OR TO ORDER

MODELS: 0756/0756D

SUGGESTED SPECIFICATION:

Provide and install, as shown on plans and/or schedules, ceiling fire dampers as manufactured by Nailor Industries, qualified for use in specific wood truss ceiling assemblies with a 1 hour fire rating. Dampers shall be tested and manufactured in accordance with UL 555C Standard for Ceiling Dampers and UL 263 Standard for Fire Tests of Building Construction and Materials, and shall bear a UL label. Each ceiling damper shall be held open with a 212°F (100°C) UL Listed fusible link (or specifier to select 165°F (74°C)), and shall be of sizes as indicated. Ceiling damper assembly shall be provided from the factory with a steel plenum/sub-frame with round connection collar(s) of size indicated on drawings. All ceiling dampers shall ship with and be installed in accordance with manufacturer's UL installation instructions. Information submitted for approval shall include same UL installation instructions.

For applications where ductwork terminates at the ceiling, standard of acceptance shall be Nailor Industries Model 0756. A grille/diffuser of minimum 26 ga. (0.55) steel construction and of model specified shall be provided by Nailor Industries to ensure correct fit.

For applications where ductwork is required to continue down past ceiling, plenum (damper sleeve) shall extend down below ceiling suitable for ducted connection. Standard of acceptance in this case shall be Nailor Industries Model 0756D.

HOW TO ORDER:

Order by model number and ceiling opening size. Select round connection collar(s) diameter (4" (102) through 10" (254) dia.) and number of collars (maximum of 3). Then list any options (if desired).

Note: Collars(s) diameter (maximum 10" (254) dia.) must not exceed listed size – 1" (25).

ie: 8" x 8" (203 x 203) ceiling opening size may have up to 7" (178) dia. maximum collar(s) size.

| | OPTION CODE | DESCRIPTION |
|----------------------|-------------|---|
| FUSIBLE LINK: | 165 | 165°F (74°C) UL Listed Fusible Link |
| ACCESSORIES: | ISA | Installation Support Angles (One Pair) 26" (660) Long. 3/4" x 3/4" x 16 ga. (19 x 19 x 1.6). |
| | ISB | Installation Support Angles (One Pair) 26" (660) Long. 1 1/2" x 1 1/2" x 22 ga. (38 x 38 x 0.85). |

- FOR WOOD TRUSS CEILING ASSEMBLIES
UL DESIGNS L550/L562/
L574/L579 & P531/P538/P545
- FIBERGLASS PLENUM &
SIDE INLET (BY OTHERS)

MODELS:

- 0757** **GRILLE MOUNT**
0757D **DUCTED**



Model Series 0757 ceiling radiation dampers have been designed and tested for simple installation in specific wood truss ceiling assemblies. They are UL Classified for use in 1 hour rated UL floor/ceiling design numbers L550/L562/L574/L579 and roof/ceiling design numbers P531/P538/P545. Available in grille mount style Model 0757, or ducted style Model 0757D, both configurations are designed for use in a fiberglass ductboard plenum, by others. Model 0757 is designed to accommodate a steel grille/diffuser in applications where the plenum terminates at the ceiling. Model 0757D can be used to provide a multi-outlet plenum to feed 0757 grille/diffuser assembly and has a damper sleeve that extends below the ceiling, suitable for ducted connection.

QUALIFICATIONS:

- UL 263 Classified Ceiling Radiation Damper. Category CABS. (File # R9660).
- California State Fire Marshal: Ceiling Damper Listing No. 3226-0935:114.
- City of New York MEA No. 366-03-M.
- 1 hour rated for use in UL floor/ceiling design #'s L550/L562/L574/L579 and roof/ceiling design #'s P531/P538/P545 (Similar in construction to designs L521/L546 & P522 respectively).
- Meets NFPA 90A requirements.

MODEL 0757 STANDARD CONSTRUCTION:

1. UL listed fusible link, 212°F (100°C) standard.
2. Blades: 22 ga. (0.85) G60 roll-formed galvanized steel.
3. Blade Insulation: Non-asbestos UL Classified.
4. Frame/sub-frame: 22 ga. (0.85) G60 galvanized steel.
5. Fiberglass plenum by others.
6. Cutting and installation of collars for UL Classified Class 0 or 1 Flexible Air Duct connection by others. Maximum of three.
7. Damper sub-frame with plaster flange. Min. 26 ga. (0.55) galvanized steel.
8. Model 0757. Steel grille/diffuser (by Nailor or others). Bottom of damper sub-frame is flush with ceiling. Standard depth for grille clearance is 2 1/2" (64).

OPTIONS:

1. 165°F (74°C) UL listed fusible link.
2. Installation Support Angles. 26" (660) long.
ISA 2 @ 3/4" x 3/4" x 16 ga. (19 x 19 x 1.6).
ISB 2 @ 1 1/2" x 1 1/2" x 22 ga. (38 x 38 x 0.85).

Minimum Size: 6" W x 4" H (152 x 102)

Maximum Size: 21" W x 18" H (533 x 457)

Maximum field cut dia. opening in fiberglass plenum is listed size - 1" (25). 10" (254) maximum diameter.

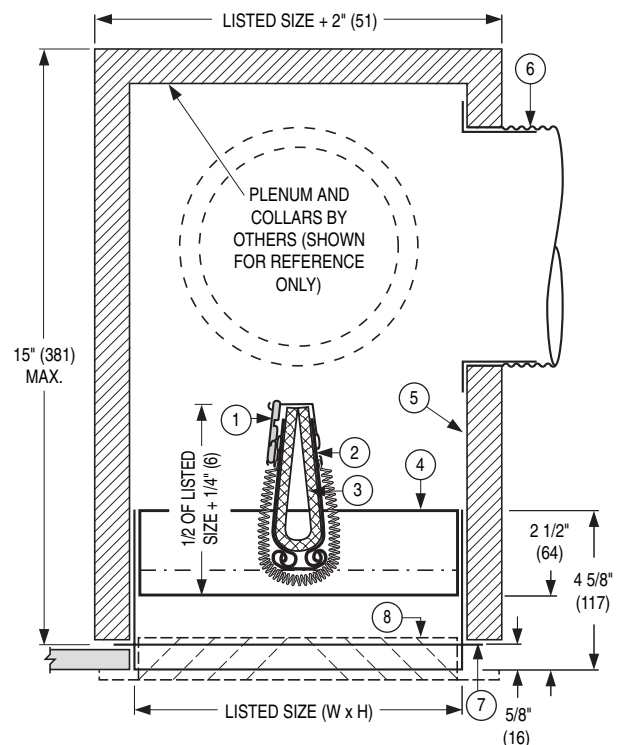

MODEL 0757

MODEL 0757D

STANDARD CONSTRUCTION:

1. UL listed fusible link, 212°F (100°C) standard.
2. Blades: 22 ga. (0.85) G60 roll-formed galvanized steel.
3. Blade Insulation: Non-asbestos UL Classified.
4. Damper frame: 22 ga. (0.85). G60 galv. steel.
5. Fiberglass plenum by others.
6. Cutting and installation of collars for UL Classified Class 0 or I Flexible Air Duct connection by others. Maximum of three.
7. Damper sub-frame with plaster flange. Min. 26 ga. (0.55) galvanized steel.
8. Damper sleeve is extended below ceiling for ducted connection.

OPTIONS:

1. Non-standard temp. UL listed fusible link
 - 165°F (74°C)
2. Installation Support Angles. 26" (660) long.
 - ISA 2 @ 3/4" x 3/4" x 16 ga. (19 x 19 x 1.6) or
 - ISB 2 @ 1 1/2" x 1 1/2" x 22 ga. (38 x 38 x 0.85)

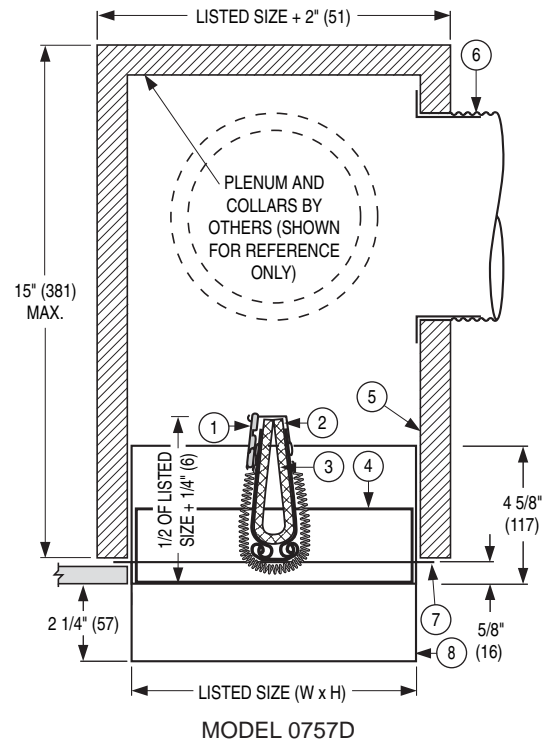

HOW TO SPECIFY OR TO ORDER

MODELS: 0757/0757D

SUGGESTED SPECIFICATION:

Provide and install, as shown on plans and/or schedules, ceiling fire dampers as manufactured by Nailor Industries, qualified for use in specific wood truss ceiling assemblies with a 1 hour fire rating. Dampers shall be tested and manufactured in accordance with UL 555C Standard for Ceiling Dampers and UL 263 Standard for Fire Tests of Building Construction and Materials, and shall bear a UL label. Each ceiling damper shall be held open with a 212°F (100°C) UL Listed fusible link (or specifier to select 165°F (74°C)), and shall be of sizes as indicated. Ceiling damper assembly shall be provided from the factory with a steel sub-frame of minimum 22 ga. (0.85) steel and of length to suit application (grille mount or continuing duct). Each ceiling damper assembly shall be installed with a UL 181 Class 1 Classified fiberglass plenum (by others). Round inlets, of size(s) shown on plans, shall be cut by contractor and collars (by others) installed by contractor. All ceiling dampers shall be installed in accordance with manufacturer's UL installation instructions. Information submitted for approval shall include same UL installation instructions.

For applications where ductwork terminates at the ceiling, standard of acceptance shall be Nailor Industries Model 0757.

For Model 0757 a grille/diffuser of minimum 26 ga. (0.55) steel construction and of model specified shall be provided by Nailor Industries to ensure correct fit.

For applications where ductwork is required to continue down past ceiling, standard of acceptance shall be Nailor Industries Model 0757D.

HOW TO ORDER:

Order by model number and ceiling opening size (W x H). List any options (if desired).

| | OPTION CODE | DESCRIPTION |
|----------------------|-------------|---|
| FUSIBLE LINK: | 165 | 165°F (74°C) UL Listed Fusible Link |
| ACCESSORIES: | ISA | Installation Support Angles (One Pair) 26" (660) Long. 3/4" x 3/4" x 16 ga. (19 x 19 x 1.6). |
| | ISB | Installation Support Angles (One Pair) 26" (660) Long. 1 1/2" x 1 1/2" x 22 ga. (38 x 38 x 0.85). |

H
CEILING DAMPERS

- REGISTER BOX
- FOR WOOD TRUSS CEILING ASSEMBLIES
- UL DESIGNS L550/L562 & P531/P538

MODELS:

- 0758 SIDE INLET
- 0759 SIDE INLET, INSULATED
- 0760 45° INLET, INSULATED
- 0761 TOP INLET
- 0762 TOP INLET, INSULATED

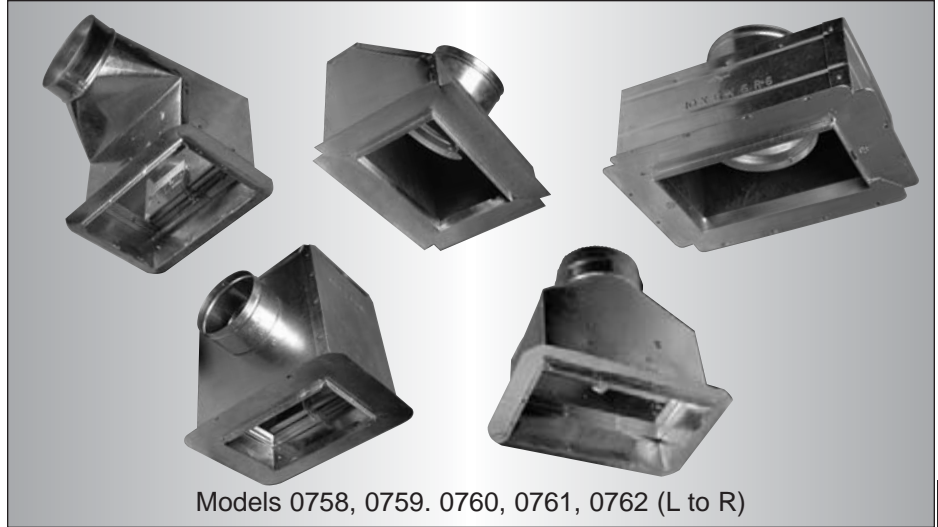

Models 0758, 0759, 0760, 0761, 0762 (L to R)

Ceiling dampers are designed to function as a heat barrier in air handling openings penetrating fire resistance membrane ceilings. Model 0758, 0759, 0760, 0761, 0762 register boxes with integral ceiling dampers have been specially designed and tested to provide protection and simple installation in specific UL design wood truss ceiling assemblies.

QUALIFICATIONS:

- UL 263 Classified Ceiling Radiation Damper. Category CABS. (File # R9660).
- 1 hour rated for use in UL floor/ceiling design #'s L550/L562 and roof/ceiling design #'s P531/P538 (Similar in construction to designs L521/L546 and P522).
- Meets NFPA 90A requirements.

MODEL 0758

STANDARD CONSTRUCTION:

1. UL listed fusible link, 212°F (100°C) standard.
2. Blades: 22 ga. (0.85) G60 roll-formed galvanized steel.
3. Blade Insulation: Non-asbestos UL Classified.
4. Damper frame: 22 ga. (0.85) G60 galvanized steel.
5. Steel plenum: 26 ga. (0.55) min. with round connection collar.
6. UL Classified Class 0 or 1 Flexible Air Duct connection by others.
7. Plaster flange.
8. Steel grille/register (by Nailor or others). Standard depth for grille clearance is 2 1/2" (64).

OPTIONS:

1. 165°F (74°C) UL listed fusible link.
2. Installation Support Angles. 26" (660) long:
ISA 2 @ 3/4" x 3/4" x 16ga. (19 x 19 x 1.6).
ISB 2 @ 1 1/2" x 1 1/2" x 22 ga. (38 x 38 x 0.85).

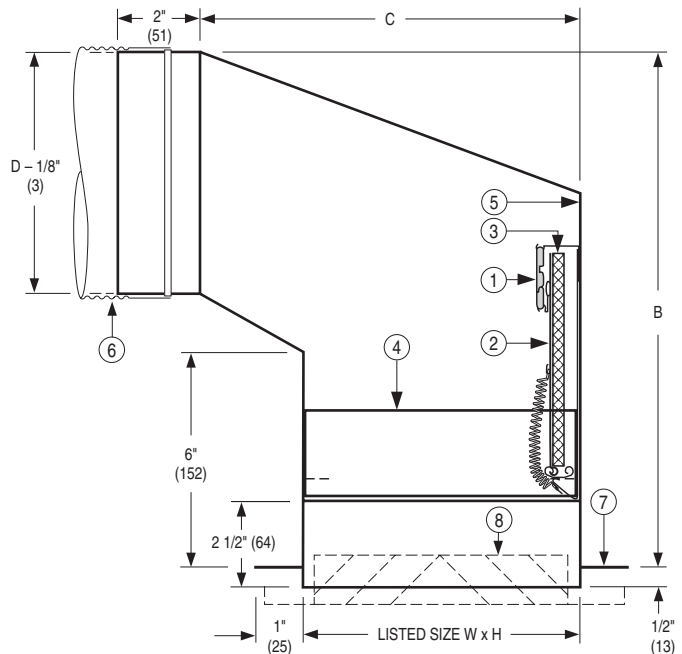

Available Sizes/Dimensional Data:

| W x H | 8x4 (203x102) | | 10x4 (254x102) | | | 12x4 (305x102) | | | 14x4 (356x102) | | 8x6 (203x156) | | | 10x6 (254x152) | | | 12x6 (305x152) | | | 14x6 (356x152) | | | 14x8 (356x203) | | |
|-------------------------|------------------|-------------|-------------------|----------------|----------------|-------------------|----------------|-----------------|-------------------|-----------------|------------------|-----------------|-------------|-------------------|-----------------|-----------------|-------------------|-----------------|-----------------|-------------------|-------------|-------------|-------------------|-------------|-------------|
| | 4" | 5" | 4" | 5" | 6" | 6" | 7" | 8" | 7" | 8" | 6" | 5" | 6" | 7" | 7" | 8" | 9" | 6" | 7" | 8" | 6" | 7" | 8" | 9" | 10" |
| Nom. Duct Size D | (102) | (127) | (102) | (127) | (152) | (152) | (178) | (203) | (178) | (203) | (152) | (127) | (152) | (178) | (178) | (203) | (229) | (152) | (178) | (203) | (152) | (178) | (203) | (229) | (254) |
| Dimension B | 11 1/2 (292) | 11 (279) | 11 1/2 (292) | | | 12 1/2 (318) | 12 (305) | 13 1/2 (343) | 13 (330) | 13 1/2 (343) | 12 (305) | 11 1/2 (292) | 12 (305) | 13 (330) | 13 1/2 (343) | 14 (356) | 14 1/2 (368) | 12 1/2 (318) | 13 1/2 (343) | 14 1/2 (368) | 13 (330) | 14 (356) | 15 (381) | 16 (406) | 17 (432) |
| Dimension C | 8 (203) | 8 (203) | 8 (203) | 7 3/4 (197) | 7 1/4 (184) | 7 3/4 (197) | 7 1/2 (191) | 7 (178) | 7 1/2 (191) | 7 (178) | 10 (254) | 9 (229) | 10 (254) | 9 1/4 (235) | 9 1/4 (235) | 10 1/4 (260) | 11 (279) | 10 (254) | 9 1/4 (235) | 9 3/4 (248) | 12 (305) | 12 (305) | 12 (305) | 13 (330) | 13 (330) |

W x H = Nominal Grille/Register size

CEILING DAMPERS

MODEL 0759

STANDARD CONSTRUCTION:

1. UL listed fusible link, 212°F (100°C) standard.
2. Blade: 22 ga. (0.85) G60 roll-formed galvanized steel.
3. Blade Insulation: Non-asbestos UL Classified.
4. Damper frame: 22 ga. (0.85) G60 galvanized steel.
5. Internal Insulation: 1" (25) R-4.3 value.
6. Steel plenum: 28 ga. (0.47) min. with round connection collar.
7. UL Classified Class 0 or I Flexible Air Duct connection by others.
8. Plaster flange.
9. Steel grille / register (by Nailor or others). Standard depth for grille clearance is 2 1/2" (64).

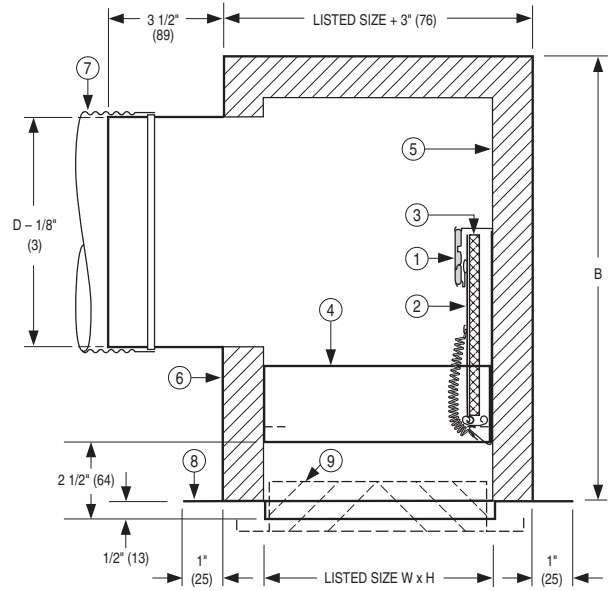

Dimensional Data:

| Available Sizes | | B |
|--------------------|-----------------------------------|----------|
| W x H | Nom. Duct Size D | |
| 8 x 4 (203 x 102) | 4" (102), 5" (127) dia. | 12 (305) |
| 10 x 4 (254 x 102) | 4" (102), 5" (127), 6" (152) dia. | |
| 12 x 4 (305 x 102) | 6" (152), 7" (178) dia. | |
| 14 x 4 (356 x 102) | 7" (178) dia. | |
| 8 x 6 (203 x 152) | 6" (152) dia. | |
| 10 x 6 (254 x 152) | 5" (127), 6" (152), 7" (178) dia. | |
| 12 x 6 (305 x 152) | 6" (152), 7" (178), 8" (203) dia. | 14 (356) |
| 14 x 6 (356 x 152) | 8" (203) dia. | |
| 14 x 8 (356 x 203) | 6" (152), 7" (178), 8" (203) dia. | |
| | 9" (229), 10" (254) dia. | |

W x H = Nominal Grille / Register Size

MODEL 0760

STANDARD CONSTRUCTION:

1. UL listed fusible link, 212°F (100°C) standard.
2. Blades: 22 ga. (0.85) G60 roll-formed galvanized steel.
3. Blade Insulation: Non-asbestos UL Classified.
4. Damper frame: 22 ga. (0.85) G60 galvanized steel.
5. Internal insulation: 1" (25) R-4.3 value.
6. Steel plenum: 28 ga. (0.47) min. with round connection collar.
7. UL Classified Class 0 or I Flexible Air Duct connection by others.
8. 1" (25) min. plaster flange.
9. Steel grille / register (by Nailor or others). Minimum depth for grille clearance is 2" (51).

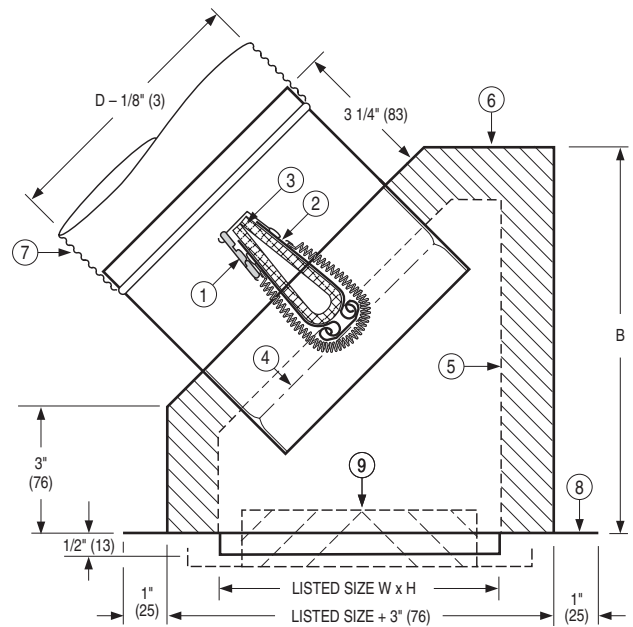

Dimensional Data:

| Available Sizes | | B |
|--------------------|-----------------------------------|--------------|
| W x H | Nom. Duct Size D | |
| 8 x 4 (203 x 102) | 4" (102), 5" (127) dia. | 9 3/4 (248) |
| 10 x 4 (254 x 102) | 4" (102), 5" (127), 6" (152) dia. | 11 1/2 (292) |
| 12 x 4 (305 x 102) | 6" (152) dia. | 13 (330) |
| | 7" (178) dia. | 14 (356) |
| 14 x 4 (356 x 102) | 7" (178), 8" (203) dia. | 15 (381) |
| 8 x 6 (203 x 152) | 6" (152) dia. | 9 1/4 (235) |
| 10 x 6 (254 x 152) | 5" (127), 6" (152), 7" (178) dia. | 9 1/4 (235) |
| 12 x 6 (305 x 152) | 6" (152), 7" (178) dia. | 10 (254) |
| 14 x 6 (356 x 152) | 6" (152), 7" (178), 8" (203) dia. | 12 (305) |
| 14 x 8 (356 x 203) | 6" (152), 7" (178), 8" (203) dia. | 12 (305) |

W x H = Nominal Grille / Register Size

H
CEILING DAMPERS

MODEL 0761

STANDARD CONSTRUCTION:

1. UL listed fusible link, 212°F (100°C) standard.
2. Blades: 22 ga. (0.85) G60 roll-formed galvanized steel.
3. Blade Insulation: Non-asbestos UL Classified.
4. Damper frame: 22 ga. (0.85) G60 galvanized steel.
5. Steel plenum: 26 ga. (0.55) min. with round connection collar.
6. UL Classified Class 0 or I Flexible Air Duct connection by others.
7. Plaster flange.
8. Steel grille / register (by Nailor or others). Minimum depth for grille clearance is 2 1/2" (64).

Dimensional Data:

| Available Sizes | | B |
|--------------------|-----------------------------------|----------|
| W x H | Nom. Duct Size D | |
| 8 x 4 (203 x 102) | 4" (102), 5" (127) dia. | 10 (254) |
| 10 x 4 (254 x 102) | 4" (102), 5" (127), 6" (152) dia. | |
| 12 x 4 (305 x 102) | 6" (152), 7" (178) dia. | |
| 14 x 4 (356 x 102) | 7" (178) dia. | |
| 8 x 6 (203 x 152) | 6" (152) dia. | |
| 10 x 6 (254 x 152) | 5" (127), 6" (152), 7" (178) dia. | |
| 12 x 6 (305 x 152) | 6" (152), 7" (178), 8" (203) dia. | |
| 14 x 6 (356 x 152) | 6" (152), 7" (178), 8" (203) dia. | |
| 8 x 8 (203 x 203) | 6" (152) dia. | |
| 10 x 8 (254 x 203) | 7" (178), 8" (203) dia. | |
| 12 x 8 (305 x 203) | 7" (178), 8" (203) dia. | 11 (279) |
| 14 x 8 (356 x 203) | 6" (152), 7" (178), 8" (203) dia. | |
| | 9" (229), 10" (254) | |

W x H = Nominal Grille / Register Size

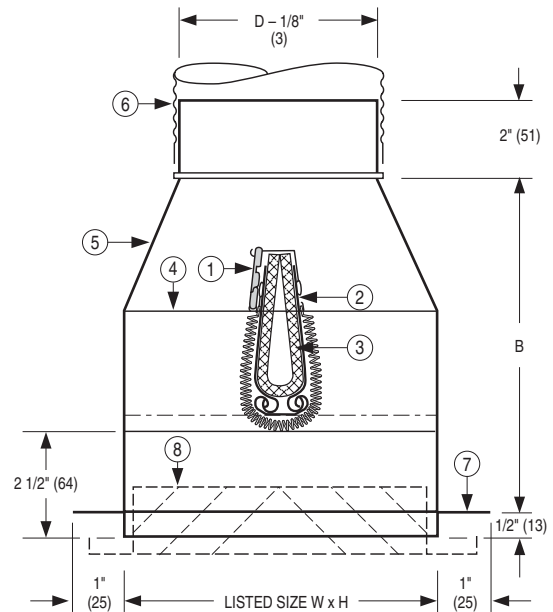

MODEL 0762

STANDARD CONSTRUCTION:

1. UL listed fusible link, 212°F (100°C) standard.
2. Blades: 22 ga. (0.85) G60 roll-formed galvanized steel.
3. Blade Insulation: Non-asbestos UL Classified.
4. Damper frame: 22 ga. (0.85) G60 galvanized steel.
5. Internal Insulation: 1" (25) R-4.3 value.
6. Steel plenum: 28 ga. (0.47) min. with round connection collar.
7. UL Classified Class 0 or I Flexible Air Duct connection by others.
8. Plaster flange.
9. Steel grille / register (by Nailor or others). Minimum depth for grille clearance is 2" (51).

Dimensional Data:

| Available Sizes | |
|--------------------|-----------------------------------|
| W x H | Nom. Duct Size D |
| 8 x 4 (203 x 102) | 4" (102), 5" (127) dia. |
| 10 x 4 (254 x 102) | 4" (102), 5" (127), 6" (152) dia. |
| 12 x 4 (305 x 152) | 6" (152), 7" (178) dia. |
| 8 x 6 (203 x 152) | 6" (152) dia. |
| 10 x 6 (254 x 152) | 5" (127), 6" (152), 7" (178) dia. |
| 12 x 6 (305 x 152) | 6" (152), 7" (178), 8" (203) dia. |
| 14 x 6 (356 x 152) | 6" (152), 7" (178), 8" (203) dia. |
| 14 x 8 (356 x 203) | 6" (152), 7" (178), 8" (203) dia. |

W x H = Nominal Grille / Register Size

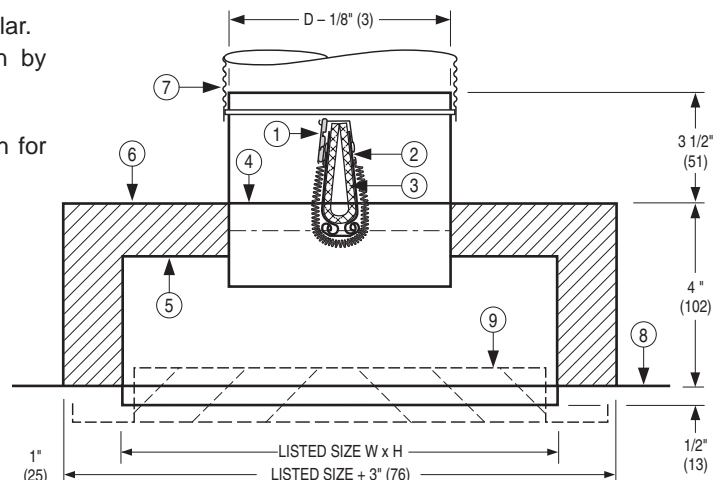

HOW TO ORDER

MODELS: 0758, 0759, 0760, 0761, 0762

HOW TO ORDER:

Order by model number, register size (W x H), and inlet size (dia.). List any options(if desired).

| | OPTION CODE | DESCRIPTION |
|----------------------|-------------|---|
| FUSIBLE LINK: | 165 | 165°F (74°C) UL Listed Fusible Link |
| ACCESSORIES: | ISA | Installation Support Angles (One Pair) 26" (660) Long. 3/4" x 3/4" x 16 ga. (19 x 19 x 1.6). |
| | ISB | Installation Support Angles (One Pair) 26" (660) Long. 1 1/2" x 1 1/2" x 22 ga. (38 x 38 x .85). |

H

CEILING DAMPERS

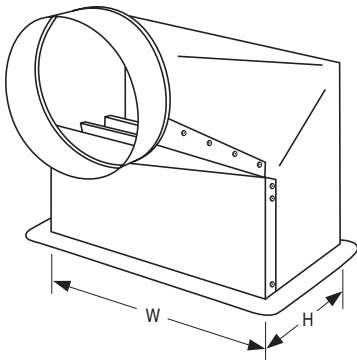

MODEL 0758

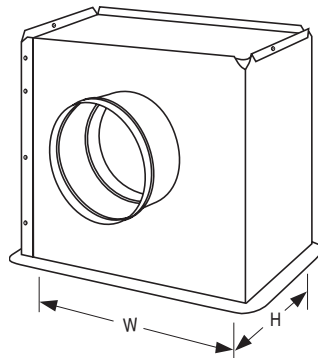

MODEL 0759

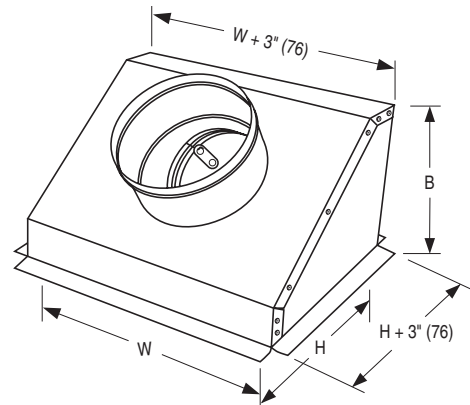

MODEL 0760

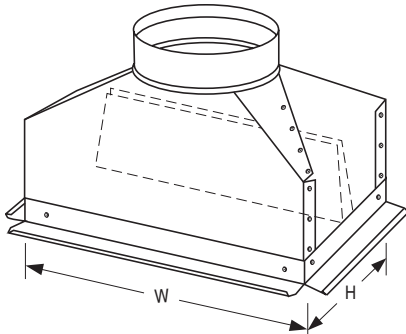

MODEL 0761

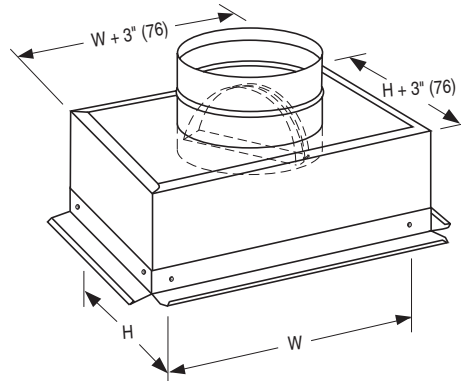

MODEL 0762