

CONTROL & BACKDRAFT DAMPERS

 **Nailor**
Industries Inc.

Contents

	Page No.
Product Overview	B4
Features of Nailor Control Dampers	B10
Standard Performance Control Dampers	
Models 1010/1020 • Low Leakage • Vee-Blades	B11
Models 1010/1020 with 13 Ga. Frame • Low Leakage • Vee-Blades	B15
Models 1010/1020 Stainless Steel • Low Leakage • Vee-Blades	B19
Models 1012/1022 • Unsealed • Vee-Blades	B23
Model 1090 • Round • Low Leakage	B27
High Performance Control Dampers	
Models 1110/1120 • Steel Airfoil Blades • Low Leakage	B31
Models 2010/2020 • Aluminum Airfoil Blades • Ultra Low Leakage	B35
Models 2010EAF/2020EAF • Extruded Aluminum Frame & Airfoil Blades • Ultra Low Leakage	B39
Models 2010IBF/2020IBF • Insulated • Ultra Low Leakage • Airfoil Blades	B43
Manual Balancing Dampers	
Models 1810/1820 • Vee-Blades	B47
Model 1870 • Single Blade	B50
Model 1890 • Round • Single Blade	B52
Options/Accessories	
Material Options	
304 • Stainless Steel Construction	B55
ALS • Aluminum Construction/Stainless Steel Hardware	B55
EAF • Extruded Aluminum Frame	B55
SSF • Stainless Steel Frame	B55
Bearing Options	
BO • Oilite Bronze Bearings	B55
BS • Stainless Steel Bearings	B55
BT • Thrust Bearings	B55
Flanged Frames	
FF/FFB • Flanged Front	B56
FR/FRB • Flanged Rear	B56
FD/FDB • Flanged Double Side	B56
Jamb Seals	
JSM • Metallic Jamb Seal	B57
JSS • Stainless Steel Jamb Seals	B57

Contents

Page No.

Options/Accessories

Round / Oval Transitions

CR • Round Transitions B57

CO • Oval Transitions B57

Linkage Material Options

SSL • Stainless Steel Linkage B58

SSA • Stainless Steel Axles Only B58

Drive Shaft Options

DLO • Lock-On Drive Shaft B58

DSR • Rigid Drive Shaft B58

Blade Seal Options for 1012/1022

BSP • Polyurethane Blades Seals B58

Blade Stop Options for 1090

FMS • Full Metal Blade Stop B59

Blade Linkage Options

LF • Face Linkage (In Airstream) B59

Manual Locking Quadrants

HLQ • Hand Locking Quadrant B60

HL2 • HLQ With 2" (51) Stand-Off B60

SB • 2" (51) Stand-Off Bracket For Square Drives B61

Pull Chain Operators

PCE • External Pull Chain Operator B61

PCI • Internal Pull Chain Operator B61

Jack Shafting & Accessories

JK5 • 1/2" (13) Dia. Jack Shaft B62

JK1 • 1" (25) Dia. Jack Shaft B62

Crankarms & Swivels B62

Vertical Damper Sections Interconnection

VCK • Vertical Interconnection Kit B63

Backdraft Dampers

Model 1370 • Standard Performance • Medium Duty B64

Model 1380 • High Performance • Heavy Duty B66

Counterbalanced Backdraft Dampers

Model 1370CB • Standard Performance • Medium Duty B68

Model 1380CB • High Performance • Heavy Duty B70

Model 1390CB • Steel Frame • High Performance • Heavy Duty B74

GENERAL PRODUCT OVERVIEW

With today's stringent design criteria for energy efficient 'green' building technology and indoor air quality, individual product engineering, testing and quality of workmanship are more important than ever before. At Nailor Industries, our continuous research and development over the past thirty years, combined with our commitment to quality in manufacturing, have resulted in premium control damper products at a reasonable cost. Our standard performance control dampers meet the requirements of the majority of low to medium velocity and pressure commercial HVAC systems. Our high performance control dampers offer unsurpassed leakage that meets the International Energy Conservation Code maximum leakage for building envelope dampers criteria of 3 cfm/ft² (15.2 l/s/m²) and offer low pressure drop characteristics suitable for use in high velocity, medium pressure commercial and industrial applications.

MODELS 1010 & 1020

VEE BLADE • LOW LEAKAGE CONTROL DAMPER

The 1010/1020 Series are Nailor's most widely used low leakage dampers and are the standard choice for use in the majority of low to medium velocity and pressure commercial HVAC systems. They are low cost, high quality dampers that meet or exceed the majority of standard specification requirements. They meet the frequently specified leakage criteria of less than 10 cfm per sq. ft at 4" w.g. (0.5% at 2000 fpm). The design features include a sturdy hat channel frame with die-formed corner gussets for reinforcement and structural strength equivalent to 13 gauge channel type frames, a triple-vee blade design that maximizes strength and zero maintenance concealed linkage (out of the air stream) for reduced pressure drop and air turbulence.

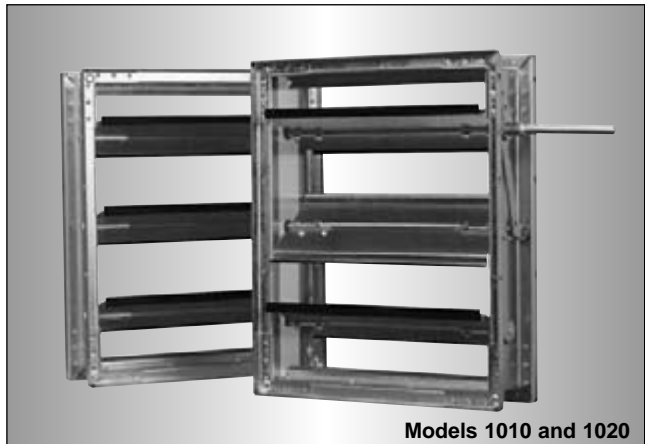

Models 1010 and 1020



Model 1020 with 13 ga. frame

MODELS 1010 & 1020 WITH 13 GA. FRAME

VEE BLADE • LOW LEAKAGE CONTROL DAMPER

Nailor Models 1010/1020 with optional 13 Gauge Frame offer low leakage and high value provided in a traditional 13 ga. frame that is fully welded for maximum strength and rack-free installation. For use in most low to medium velocity and pressure commercial HVAC applications, the 1010/1020 with 13 Gauge Frame are low cost, high quality dampers that meet the frequently specified leakage criteria of less than 10 cfm per square foot at 4 in. w.g. The design features also include a triple-vee blade design that maximizes strength and zero-maintenance concealed linkage (out of the airstream) for reduced pressure drop and air turbulence.

MODELS 1010 & 1020 IN 304 STAINLESS STEEL

VEE BLADE • LOW LEAKAGE CONTROL DAMPER

Nailor Models 1010/1020 with optional 304 Stainless Steel construction provide an enduring solution for corrosive environment commercial and industrial HVAC and process applications. The proven triple-vee blade design and sturdy hat channel mitered frame with die-formed corner gussets afford solid performance that will withstand many normally harsh atmospheric and process elements. The design also features stainless steel zero-maintenance concealed blade linkage for reduced pressure drop and turbulence, and stainless steel axles, bushings and hardware for long lasting operation suitable for use in applications with temperatures ranging from -50°F (-45°C) to 250°F (121°C) depending on blade configuration and leakage (seals) requirements.



Model 1020-304

GENERAL PRODUCT OVERVIEW

MODELS 1012 & 1022

VEE BLADE • UNSEALED CONTROL DAMPER

The 1012/1022 Series are Nailor's most widely used unsealed dampers and are the standard choice for use in the majority of low to medium pressure and velocity commercial HVAC systems. They are low cost, high quality dampers that meet or exceed the majority of standard specification requirements. The design features include a sturdy hat channel frame with die-formed corner gussets for reinforcement and structural strength equivalent to 13 gauge channel type frames, a triple-vee blade design that maximizes strength and zero maintenance concealed linkage (out of the air stream) for reduced pressure drop and air turbulence.

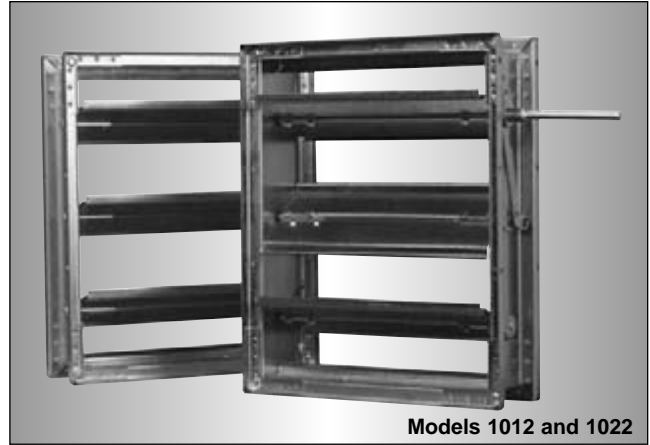

Models 1012 and 1022

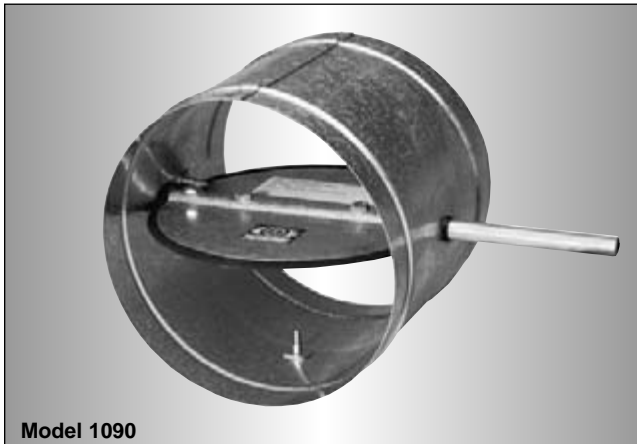

Model 1090

MODEL 1090

ROUND DUCT • LOW LEAKAGE CONTROL DAMPER

The Nailor Model 1090 is a low leakage, butterfly damper which has been designed for all types of round ductwork applications and is suitable for use in the majority of low to medium pressure and velocity commercial HVAC systems. The design features a sturdy beaded casing for superior rigidity, and a laminated blade double bolted to axle and drive shaft for maximum strength. The 1090 installs easily in round spiral ductwork. The damper may be used for two position or modulating control using a variety of electric or pneumatic actuators or may also be used as a manual balancing damper when used with the optional hand locking quadrant and positive shut-off is required.

MODELS 1110 & 1120

STEEL AIRFOIL BLADE • LOW LEAKAGE HIGH PERFORMANCE CONTROL DAMPER

The 1110/1120 Series are Nailor's most cost effective steel airfoil blade control dampers. They are suitable for use in the majority of low to medium pressure and velocity commercial HVAC systems.

The design features include a sturdy hat channel frame with die-formed corner gussets for reinforcement and structural strength equivalent to 13 gauge channel type frames and zero maintenance concealed linkage (out of the air stream) for reduced pressure drop and air turbulence. Ultra-low leakage meeting the International Energy Conservation Code criteria for building envelope dampers of maximum 3 cfm/ft² (15.2 l/s/m²).



Models 1110 and 1120

GENERAL PRODUCT OVERVIEW

MODELS 2010 & 2020

EXTRUDED ALUMINUM AIRFOIL BLADE • ULTRA-LOW LEAKAGE • HIGH PERFORMANCE CONTROL DAMPER

Premium choice for use in high velocity, medium pressure commercial and industrial HVAC systems. They offer unsurpassed leakage and pressure drop characteristics for superior performance. Model 2020 opposed blade, is an AMCA licensed damper and provides the ultimate in ultra-low leakage performance characteristics. Standard features include a rugged galvanized steel hat channel frame with die-formed corner gussets for strength, no-maintenance concealed linkage, and heavy duty extruded aluminum airfoil blades that combine superior rigidity and deflection resistance with low pressure drop. Unique design compression type seals are keyed and locked into blade extrusion.



Model 2020



Model 2010EAF

MODELS 2010EAF & 2020EAF

EXTRUDED ALUMINUM AIRFOIL BLADE & FRAME ULTRA-LOW LEAKAGE • HIGH PERFORMANCE CONTROL DAMPER

Extruded aluminum airfoil blade and frame premium damper, ideal for use in high velocity, medium pressure, commercial and industrial HVAC systems. They offer unsurpassed leakage and pressure drop characteristics for superior performance. Model 2020EAF opposed blade, is an AMCA licensed damper and provides the ultimate in ultra-low leakage performance characteristics. Features include a heavy duty extruded aluminum hat channel frame, no-maintenance concealed linkage, and rugged extruded aluminum airfoil blades that combine superior rigidity and deflection resistance with low pressure drop. Unique design compression type seals are keyed and locked into blade extrusion.



Model 2020IBF

MODELS 2010IB/IBF & 2020IB/IBF • INSULATED EXTRUDED ALUMINUM AIRFOIL BLADE • ULTRA-LOW LEAKAGE • HIGH PERFORMANCE CONTROL DAMPER

Premium insulated dampers featuring rugged extruded aluminum airfoil blades, suitable for use in high velocity, medium pressure commercial and industrial systems.

These ultra-low leakage dampers with insulated blade and frame, help limit thermal conductivity as well as air infiltration, making them ideal for use in more extreme applications. Features include a choice of heavy-duty frames, no-maintenance concealed linkage and unique design compression type seals that are keyed and locked into the blade extrusion.

GENERAL PRODUCT OVERVIEW

MODELS 1810 & 1820

MANUAL BALANCING DAMPERS • STEEL

Specially designed for manual balancing applications. They are suitable for use in the majority of commercial low to medium pressure and velocity HVAC systems. They are designed and built to provide a cost effective and reliable damper for reduced volume control and not positive shut-off. They are not recommended for applications as an automatic control damper. The 1810/1820 Series includes many of the design features incorporated in the Nailor 1000 Series Control Dampers. These include a sturdy hat channel frame with die-formed corner gussets for reinforcement, a vee-blade design that maximizes strength and zero maintenance concealed linkage (out of the air stream) for reduced air turbulence.

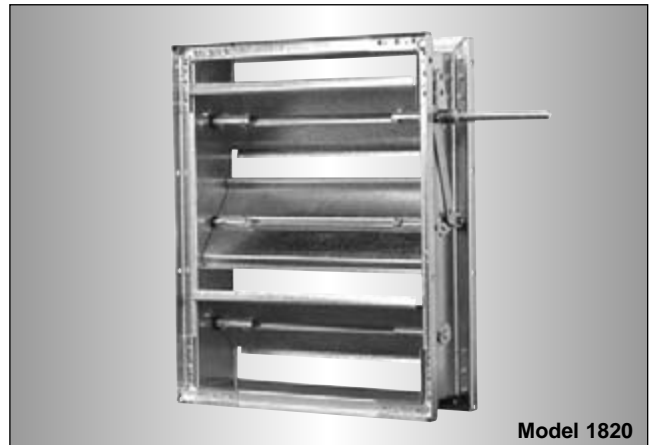

Model 1820

B

CONTROL DAMPERS

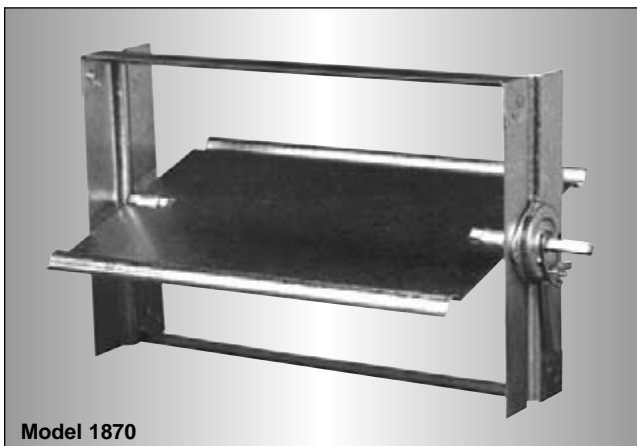

Model 1870

MODEL 1870

SINGLE BLADE • MANUAL BALANCING DAMPER STEEL

The Model 1870 Manual Balancing Damper is an economical branch duct balancing damper designed for use in most metal and fibre ductboard HVAC systems. The low profile frame and sills provide maximum free area. The ribbed forms in the blade and frame are for extra strength. A locking manual hand quadrant is provided with each damper.

MODEL 1890

FOR ROUND DUCT • MANUAL BALANCING DAMPER • STEEL

The Nailor Model 1890 is a manual balancing butterfly damper designed for all types of round ductwork applications and is suitable for use in most low pressure and velocity commercial HVAC systems. They are not intended for use as a positive shut-off or automatic control damper. The design features a sturdy beaded casing ideal for round spiral ductwork connections, and a corrosion resistant steel blade that can be locked in any position with the hand quadrant that is supplied as standard with the damper.

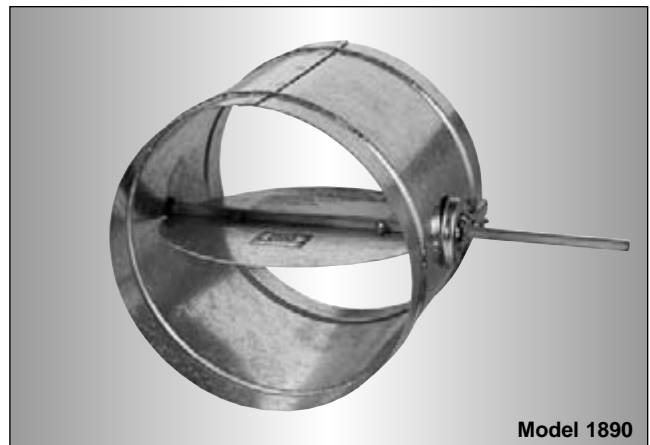

Model 1890

GENERAL PRODUCT OVERVIEW

MODEL 1370

BACKDRAFT DAMPER • EXTRUDED ALUMINUM STANDARD PERFORMANCE • MEDIUM DUTY

Model 1370 is a standard performance gravity operated backdraft damper for use in light to medium duty commercial HVAC applications. Backdraft dampers are used in systems to pass airflow in one direction and to prevent airflow in the opposite direction. Corrosion-resistant extruded aluminum construction highlights the model's features which include a reinforced mitered corner frame that resists racking, and aerodynamic blades that overlap the jambs for maximum weather protection. Extruded PVC blade seals provide quiet closure as well as extra weather protection. Blade linkage is concealed in jamb for low pressure drop and provides smooth operation at system velocities of up to 1500 fpm.

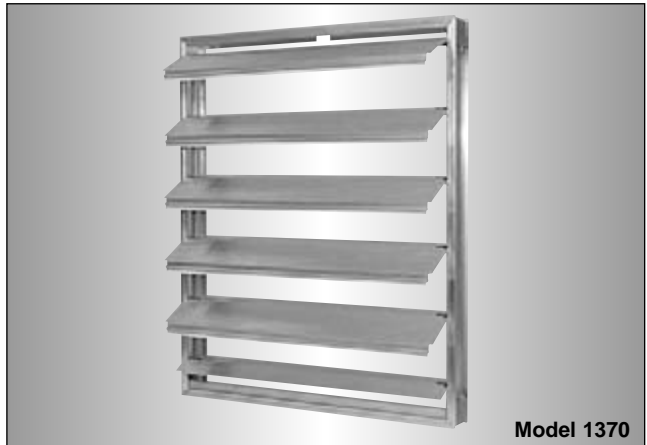

Model 1370

B

CONTROL DAMPERS



Model 1380

MODEL 1380

BACKDRAFT DAMPER • EXTRUDED ALUMINUM HIGH PERFORMANCE • HEAVY DUTY

Model 1380 is a high performance gravity operated backdraft damper for use in medium to heavy duty commercial and light industrial HVAC applications. Backdraft dampers are used in systems to pass airflow in one direction and to prevent airflow in the opposite direction. Corrosion resistant extruded aluminum construction highlights the model's features which include a reinforced mitered corner frame that resists racking, and aerodynamic blades that overlap the jambs for maximum weather protection. Extruded PVC blade seals provide quiet closure as well as extra weather protection. Blade linkage is mounted out of view on the rear of the blades and provides smooth operation at system velocities of up to 2500 fpm.

MODEL 1370CB

COUNTERBALANCED BACKDRAFT DAMPER EXTRUDED ALUMINUM • STANDARD PERFORMANCE MEDIUM DUTY

Model 1370CB is a standard performance counterbalanced backdraft damper designed to automatically prevent the backflow of air while allowing for automatic air intake or exhaust/pressure relief in medium duty HVAC applications. Corrosion-resistant extruded aluminum construction highlights the model's features which include a reinforced mitered corner frame that resists racking, and aerodynamic blades that overlap the jambs for maximum weather protection. Extruded PVC blade seals provide quiet closure as well as extra weather protection. Blade linkage is concealed in jamb for low pressure drop and provides smooth operation at system velocities of up to 1500 fpm. Blade mounted counterweights are easily adjusted to desired opening pressure.



Model 1370CB

GENERAL PRODUCT OVERVIEW

MODEL 1380CB COUNTERBALANCED BACKDRAFT DAMPER HIGH PERFORMANCE • HEAVY DUTY

Model 1380CB is a high performance counterbalanced backdraft damper designed to automatically prevent the backflow of air while allowing for automatic air intake or exhaust/pressure relief in medium to heavy duty commercial and light duty industrial HVAC applications. Corrosion-resistant extruded aluminum construction highlights the model's features which include a reinforced mitered corner frame that resists racking, and aerodynamic blades that overlap the jambs for maximum weather protection. Extruded PVC blade seals provide quiet closure as well as extra weather protection. Blade linkage is mounted out of view on the rear of the blades and provides smooth operation at system velocities of up to 2500 fpm. Blade mounted counterweights are easily adjusted to desired opening pressure.



MODEL 1390CB COUNTERBALANCED BACKDRAFT DAMPER HIGH PERFORMANCE • HEAVY DUTY STEEL FRAME

Model 1390CB is a counterbalanced backdraft damper designed for pressure relief to automatically assist in maintaining and limiting desired pressures in medium to heavy duty commercial and light duty industrial HVAC or process air systems. The unique extruded aluminum blade design and fully adjustable counterbalance assembly offer pressure relief at extremely low pressure differentials. The rugged steel mitered corner frame is reinforced to resist racking, and ball bearings provide extreme sensitivity and ultra-smooth operation. Neoprene blade seals provide quiet closure as well as extra weather protection.

Features of Nailor Control Dampers

At Nailor, we take pride in putting our thirty years of experience in manufacturing premium quality dampers to work for *you* with every control damper we make. We've learned a lot since producing our first damper and have incorporated that knowledge into the latest designs and features that are offered today. And with Nailor dampers *you're in control!* We'll manufacture *your* control dampers with built-in quality features shown below and with a multitude of options *you* can select from to meet *your* specific requirements. And with Nailor's fast lead times, *your* control dampers will be on site when *you* want. Premium quality, reasonable cost, versatility and quick lead times are just some of our standard features...

Nailor's robust blade linkage provides firm, precise blade connections for smooth operation, concealed in frame, out of airstream for reduced turbulence and pressure drop. Double linkage provided on units 30" (762) wide and over.

Rugged 16 ga. (1.6) hat channel frame design provides strength equivalent to heavier gauge U-channel frames.

Corners are mitered and reinforced with die-formed gussets for superior rigidity and strength that virtually eliminates racking.

B

CONTROL DAMPERS

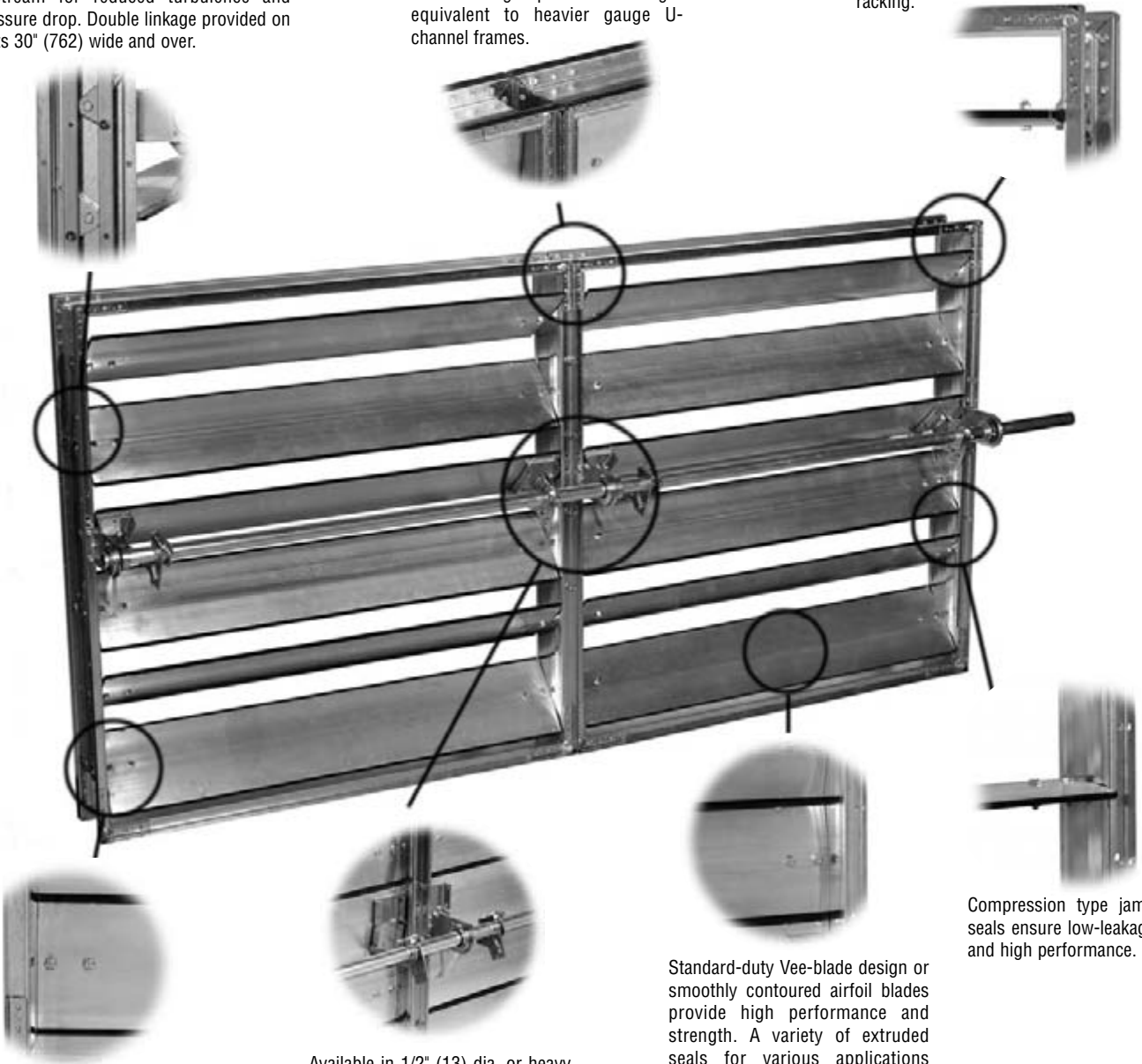

Each axle is fastened to blade end with double thru-bolts providing superior no-slip axle connections. Choice of bearings to suit application.

Available in 1/2" (13) dia. or heavy duty 1" (25) dia. shaft. Extra beefy linkage, bearing brackets and blade connections provide optimum operation on larger dampers.

Standard-duty Vee-blade design or smoothly contoured airfoil blades provide high performance and strength. A variety of extruded seals for various applications provide low-leakage characteristics that lead the industry.

Compression type jamb seals ensure low-leakage and high performance.

Quality dampers by Nailor Industries... Now you're in control!

- VEE BLADE
- STANDARD PERFORMANCE
- LOW LEAKAGE
- GALVANIZED STEEL

MODELS:

- 1010 PARALLEL BLADE**
- 1020 OPPOSED BLADE**

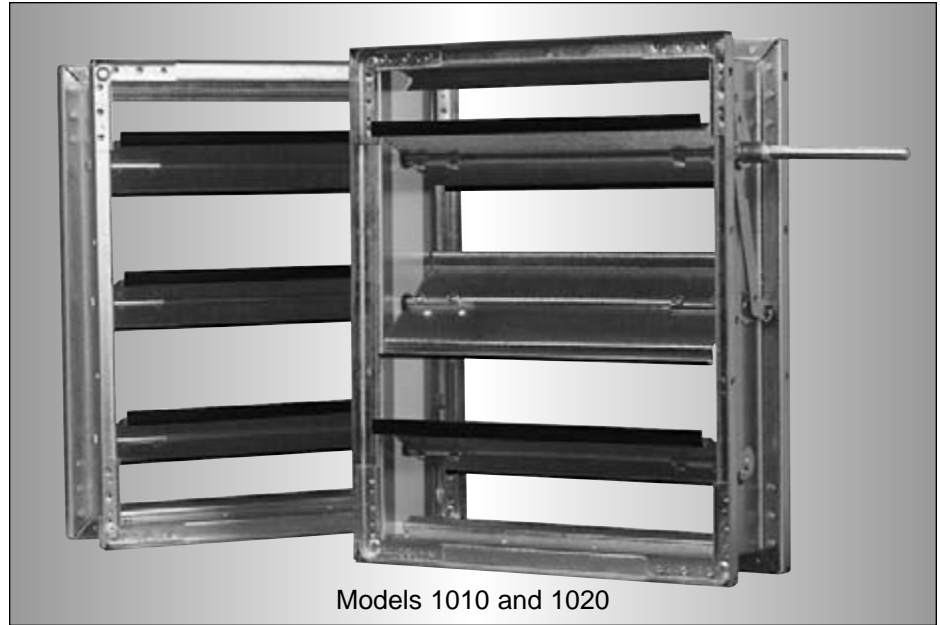

Models 1010 and 1020

The 1010/1020 Series are Nailor's most widely used low leakage dampers and are the standard choice for use in the majority of low to medium velocity and pressure commercial HVAC systems. They are low cost, high quality dampers that meet or exceed the majority of standard specification requirements. They meet the frequently specified leakage criteria of less than 10 cfm per sq. ft at 4" w.g. (0.5% at 2000 fpm). The design features include a sturdy hat channel frame with die-formed corner gussets for reinforcement and structural strength equivalent to 13 gauge channel type frames, a triple-vee blade design that maximizes strength and zero maintenance concealed linkage (out of the air stream) for reduced pressure drop and air turbulence.

B CONTROL DAMPERS

STANDARD CONSTRUCTION:

- FRAME:** 5" x 7/8" x 16 ga. (127 x 22 x 1.6) galvanized steel hat channel with die-formed corner gussets. Low profile (flat top and bottom) on dampers 10" (254) high and under.
- BLADES:** 6" (152) wide on 5 1/2" (140) centers. 16 ga. (1.6) galvanized steel triple-vee design. Parallel or opposed action.
- LINKAGE:** Concealed type totally enclosed within the frame and out of the airstream. Plated steel.
- BEARINGS:** 1/2" (13) dia. Celcon®.
- AXLES:** 1/2" (13) dia. plated steel double bolted to blades.
- DRIVE SHAFT:** 6" (152) long x 1/2" (13) dia. rigid shaft; or optional lock-on shaft with outboard support bracket (standard in Canada), on all single section dampers. A 1/2" (13) or 1" (25) dia. factory installed jackshaft is standard on all multiple section dampers.
- BLADE SEALS:** Dual durometer bulb type extruded PVC.
- JAMB SEALS:** Compression type cambered metal.
- MINIMUM SIZE:** Single blade (parallel): 6" x 4" (152 x 102).
Two blades (parallel or opposed): 6" x 10" (152 x 254).
- MAXIMUM SIZE:** Single section: 48" x 72" (1220 x 1829).
Multiple section assembly - unlimited.

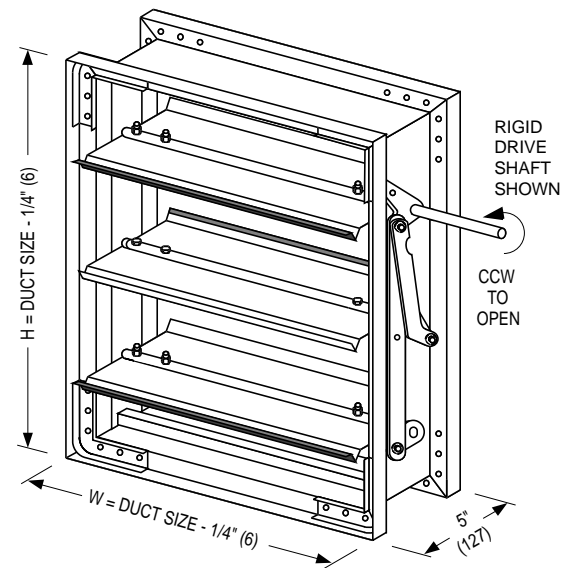

MODEL 1010
PARALLEL BLADE

MODEL 1020
OPPOSED BLADE

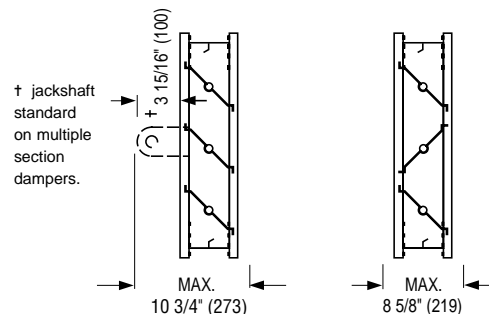

MODELS: 1010/1020

PERFORMANCE DATA:

B CONTROL DAMPERS

PRESSURE DROP (damper fully open)

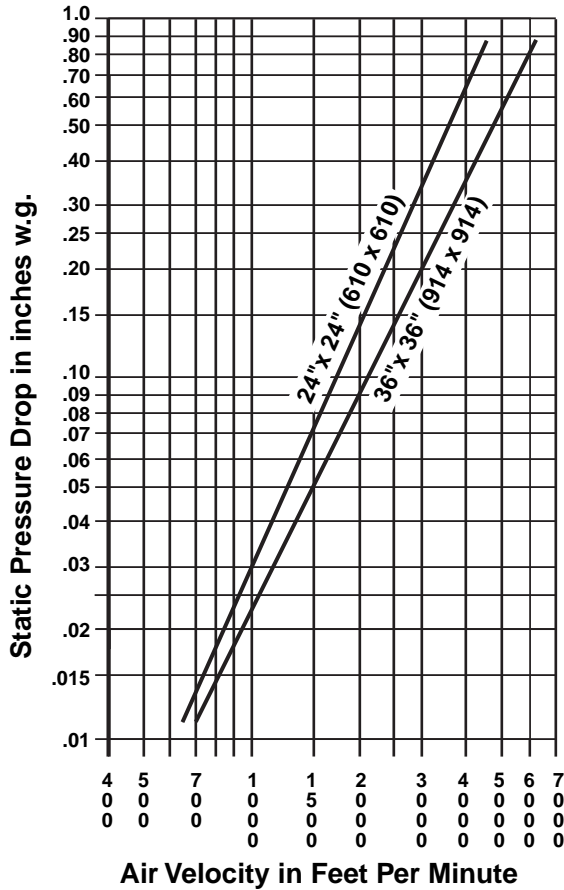

Tested per AMCA standard 500-D, Fig. 5.3.

LEAKAGE (damper fully closed)

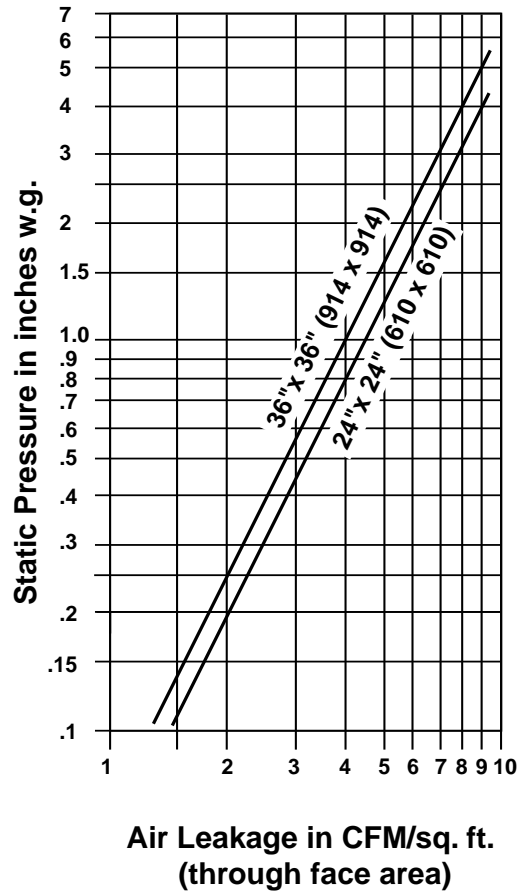

Tested per AMCA standard 500-D, Fig. 5.5.

Imperial figures shown.
To convert to SI (metric) system:
 Multiply:
 CFM x .4719 = liters per second
 inches w.g. x .2486 = kilopascals
 fpm x .00508 = meters per second
 cfm per sq. ft. x 5.08 = liters/second per sq. meter.

PRESSURE DROP (in. w.g.)

DAMPER SIZE	APPROACH VELOCITY (FPM)			
	750	1000	1500	2000
24" x 24" (610 x 610)	.016	.030	.07	.14
36" x 36" (914 x 914)	.013	.023	.05	.09
48" x 48" (1219 x 1219)	.010	.020	.03	.07

Tested per AMCA standard 500-D, Fig. 5.3.

DYNAMIC LIMITATIONS / LEAKAGE

DAMPER WIDTH	MAXIMUM SYSTEM PRESSURE	MAXIMUM SYSTEM VELOCITY	LEAKAGE *	
			% OF MAX. FLOW	CFM/SQ. FT.
48" (1219)	2.5" w.g.	2000 FPM	0.18	3.5
36" (914)	3.0" w.g.	2000 FPM	0.20	4.0
24" (610)	4.0" w.g.	2000 FPM	0.23	4.5
12" (305)	5.0" w.g.	2000 FPM	0.33	6.6

* Leakage information is based upon a pressure differential of 1" w.g. tested per AMCA standard 500-D, Fig. 5.5.

Temperature Range: -50°F to 180°F (-45°C to 82°C)

MODELS: 1010/1020

AVAILABLE OPTIONS/ACCESSORIES:

The following construction options and accessories are available on Models 1010/1020. See page B55 for further description of options/accessories.

	CODE	DESCRIPTION
MATERIAL:	304 ALS	Stainless Steel Construction Aluminum Construction With Stainless Steel Hardware
FRAME:	FF/FFB FR/FRB FD/FDB	Front Flange / Front Flange With Bolt Holes Rear Flange / Rear Flange With Bolt Holes Double Flange / Double Flange With Bolt Holes
FRAME GAUGE:	14G 13G 12G	14 Gauge 13 Gauge 12 Gauge
BLADE LINKAGE STYLE:	LF	Face Linkage (In Airstream)
BEARINGS:	BO BS BT	Oilite® Bronze Bearings Stainless Steel Bearings Thrust Bearings
JAMB SEAL:	JSS	Stainless Steel Jamb Seal
ROUND/OVAL TRANSITION:	CR CO	Transition Casing for Round Duct Transition Casing for Oval Duct
OPERATOR ACCESSORIES:	HLQ PCE PCI FMO FMI JK5 JK1 VCK	Hand Locking Quadrant External Chain Operator Internal Chain Operator Factory Mounted Actuator-Outside w/side plate Factory Mounted Actuator-Internal w/jackshaft 1/2" (13) Dia. Jackshafting for Single Section 1" (25) Dia. Jackshafting for Single Section Vertical Interconnection Kit

B

CONTROL DAMPERS

At Nailor Industries, we take pride in our flexibility to meet the needs of your specific applications. The options listed above provide a variety of commonly used modifications to satisfy the majority of today's diverse requirements. Should your application require a more unique configuration, please consult your authorized Nailor Representative or the Nailor Industries office nearest you for assistance.

HOW TO SPECIFY OR TO ORDER

MODELS: 1010/1020

HOW TO ORDER:

Standard construction is shown in highlighted box. Option codes are listed below. See previous page for description of options.

MODEL	SIZE (W X H)	MATERIAL	FRAME TYPE	FRAME GAUGE	BLADE LINKAGE STYLE	DRIVE LOCATION	BEARINGS	BLADE SEAL	JAMB SEAL	ROUND/OVAL TRANSITION	OPERATOR ACCESSORIES
1010	ie: 48 x 24	GLV	HC	16G	LC	DR/DL	BC	BPV	JSM	–	–
1020		304 ALS	FF FFB FR FRB FD FDB	14G 13G 12G	LF		BO BT BS		JSS	CR CO	HLQ FMO FMI PCE PCI JK5 JK1 VCK

- Notes: 1. Right hand driveshaft is standard. For left hand driveshaft simply rotate the damper so that the driveshaft is on left hand side, as blade and jamb seals are designed to work with airflow in either direction. 1/2" (13) or 1" (25) dia. jackshaftering is standard on all multiple section wide units.
 2. If Pull Chain Operator option is selected, please specify length of chain required.
 3. If Option CR Round Transition casing (or CO) is selected please order by duct size diameter ie: 36"ø.

SUGGESTED SPECIFICATION:

Provide and install, as shown on plans and/or schedules, low-leakage dampers meeting or exceeding the following criteria: Frame shall be constructed of 16 ga. (1.6) galvanized steel hat channel with mitered corners and die-formed corner gussets for rigidity and structural strength equivalent to 13 ga. (2.4) channel type frames. Blades shall be of triple-vee design, 16 ga. (1.6) galvanized steel, on maximum 6" (152) centers, in parallel or opposed (please select) configuration. Blade axles shall be 1/2" (13) dia. plated steel, double thru-bolted to blade at each end. Hex or square friction-fit, or press-fit axles are not acceptable. Bearings shall be Celcon® molded synthetic type. Blade linkage shall be zero-maintenance, out of airstream and totally concealed within the frame. Jackshafts shall be supplied on all multiple section wide assemblies in order to evenly distribute torque. Blade seals shall be dual durometer bulb type extruded PVC, and jamb seals shall be compression type cambered metal, providing positive shut-off. All submitted performance data to be based on tests in accordance with AMCA Standard 500-D. Standard of acceptance: Nailor Industries Model 1010 (parallel blade) or Model 1020 (opposed blade).

For CR Round Transition Option, add the following:

Damper shall be provided with a 20 ga. (1.0) galvanized steel casing for sizes up to 36" (914) dia., 18 ga. (1.31) for larger sizes, complete with round collar on both sides. Casing shall be welded and caulked against leakage. Standard of acceptance: Nailor Industries Model 1010CR (parallel blade) or Model 1020CR (opposed blade).

- VEE BLADE
- 13 GA. FRAME
- LOW LEAKAGE
- STANDARD PERFORMANCE
- GALVANIZED STEEL

MODELS:

**1010 WITH 13 GA. FRAME
(PARALLEL BLADE)**

**1020 WITH 13 GA. FRAME
(OPPOSED BLADE)**



Model 1020 With 13 Ga. Frame

Nailor Models 1010/1020 with optional 13 Gauge Frame offer low leakage and high value provided in a traditional 13 ga. frame that is fully welded for maximum strength and rack-free installation. For use in most low to medium velocity and pressure commercial HVAC applications, the 1010/1020 with 13 Gauge Frame are low cost, high quality dampers that meet the frequently specified leakage criteria of less than 10 cfm per square foot at 4 in. w.g.. The design features also include a triple-vee blade design that maximizes strength and zero-maintenance concealed linkage (out of the airstream) for reduced pressure drop and air turbulence.

STANDARD CONSTRUCTION:

- FRAME:** 5" x 7/8" x 13 ga. (127 x 22 x 2.4) galvanized steel hat channel. Fully welded construction. Low profile (flat top and bottom) on dampers 10" (254) high and under.
- BLADES:** 6" (152) wide on 5 1/2" (140) centers. 16 ga. (1.6) galvanized steel triple-vee design. Parallel or opposed action.
- LINKAGE:** Concealed type totally enclosed within the frame and out of the airstream. Plated steel.
- BEARINGS:** 1/2" (13) dia. Celcon®.
- AXLES:** 1/2" (13) dia. plated steel double bolted to blades.
- DRIVE SHAFT:** 6" (152) long x 1/2" (13) dia. rigid shaft; or optional lock-on shaft with outboard support bracket (standard in Canada), on all single section dampers. A 1/2" (13) or 1" (25) dia. factory installed jackshaft is standard on all multiple section dampers.
- BLADE SEALS:** Dual durometer bulb type extruded PVC.
- JAMB SEALS:** Compression type cambered metal.
- MINIMUM SIZE:** Single blade (parallel): 6" x 4" (152 x 102).
Two blades (parallel or opposed): 6" x 10" (152 x 254).
- MAXIMUM SIZE:** Single section: 48" x 72" (1220 x 1829).
Multiple section assembly - unlimited.

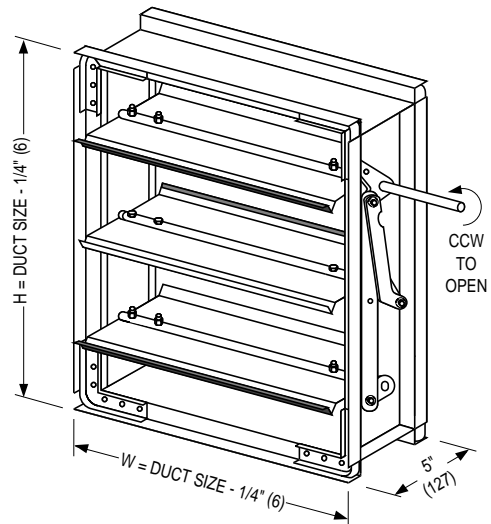

**MODEL 1010
WITH 13 GA. FRAME
PARALLEL BLADE**

**MODEL 1020
WITH 13 GA. FRAME
OPPOSED BLADE**

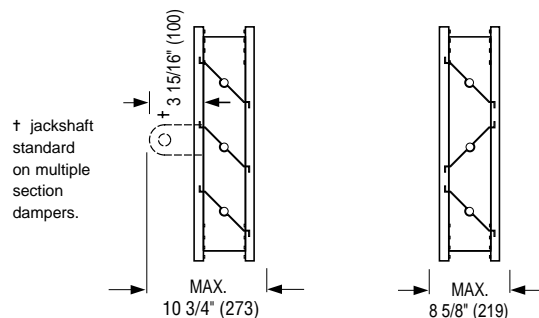

MODELS: 1010 WITH OPTIONAL 13 GA. FRAME
1020 WITH OPTIONAL 13 GA. FRAME

PERFORMANCE DATA:

B CONTROL DAMPERS

PRESSURE DROP (damper fully open)

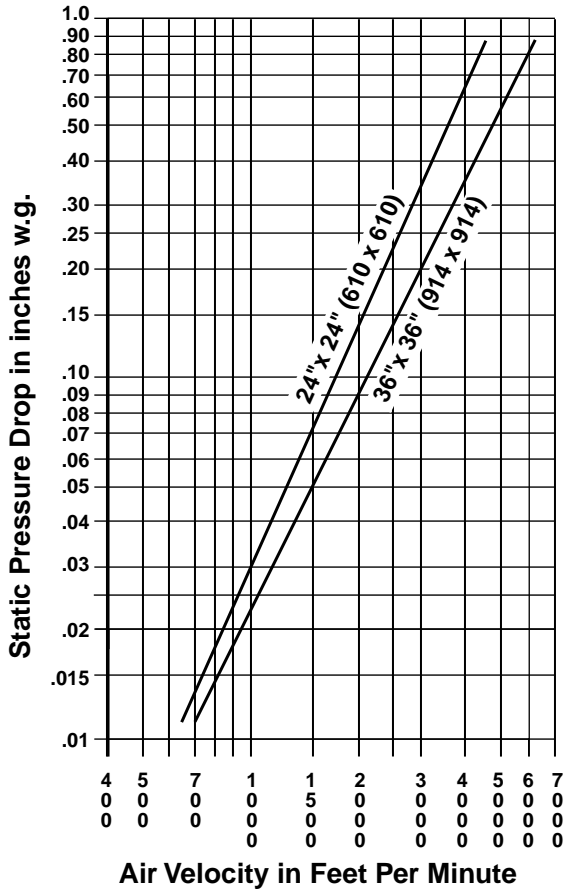

Tested per AMCA standard 500-D, Fig. 5.3.

LEAKAGE (damper fully closed)

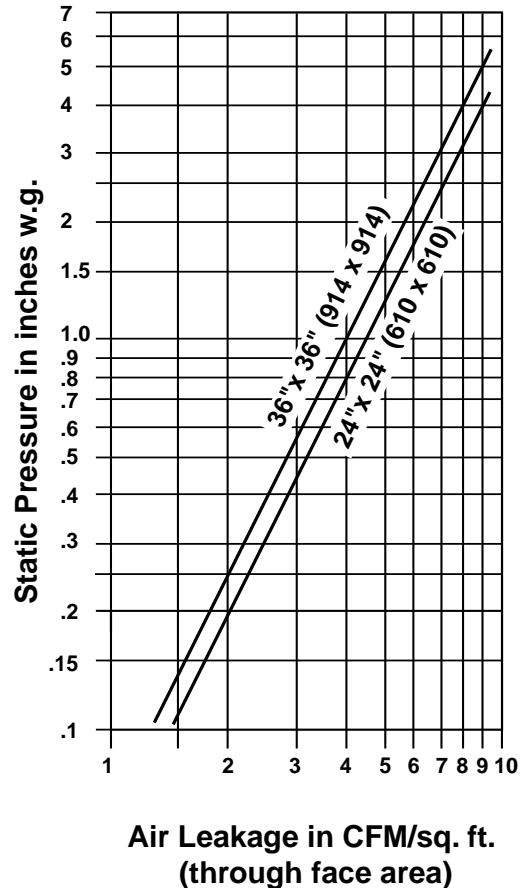

Tested per AMCA standard 500-D, Fig. 5.5.

PRESSURE DROP (in. w.g.)

DAMPER SIZE	APPROACH VELOCITY (FPM)			
	750	1000	1500	2000
24" x 24" (610 x 610)	.016	.030	.07	.14
36" x 36" (914 x 914)	.013	.023	.05	.09
48" x 48" (1219 x 1219)	.010	.020	.03	.07

Tested per AMCA standard 500-D, Fig. 5.3.

DYNAMIC LIMITATIONS/LEAKAGE

DAMPER WIDTH	MAXIMUM SYSTEM PRESSURE	MAXIMUM SYSTEM VELOCITY	LEAKAGE *	
			% OF MAX. FLOW	CFM/SQ. FT.
48" (1219)	2.5" w.g.	2000 FPM	0.18	3.5
36" (914)	3.0" w.g.	2000 FPM	0.20	4.0
24" (610)	4.0" w.g.	2000 FPM	0.23	4.5
12" (305)	5.0" w.g.	2000 FPM	0.33	6.6

* Leakage information is based upon a pressure differential of 1" w.g. tested per AMCA standard 500-D, Fig. 5.5.

Temperature Range: -50°F to 180°F (-45°C to 82°C)

MODELS: 1010/1020 WITH OPTIONAL 13 GA. FRAME

AVAILABLE OPTIONS/ACCESSORIES:

The following construction options and accessories are implemented or available on Models 1010/ 1020 WITH OPTIONAL 13 GA. FRAME.
See page B55 for further description of options/accessories.

	CODE	DESCRIPTION
MATERIAL:	GLV	Galvanized Steel Construction
FRAME:	FF FR FD	Front Flange Rear Flange Double Flange
FRAME GAUGE:	13G	13 Gauge frame
BLADE LINKAGE STYLE:	LF	Face linkage (In Airstream)
BEARINGS:	BO BS BT	Oilite® Bronze Bearings Stainless Steel Bearings Thrust Bearings
JAMB SEAL:	JSS	Stainless Steel Jamb Seals
ROUND/OVAL TRANSITION:	CR CO	Transition Casing for Round Duct Transition Casing for Oval Duct
OPERATOR ACCESSORIES:	HLQ PCE PCI FMO FMI JK5 JK1 VCK	Hand Locking Quadrant External Chain Operator Internal Chain Operator Factory Mounted Actuator-Outside w/side plate Factory Mounted Actuator-Internal w/jackshaft 1/2" (13) Dia. Jackshafting for Single Section 1" (25) Dia. Jackshafting for Single Section Vertical Interconnection Kit

B

CONTROL DAMPERS

At Nailor Industries, we take pride in our flexibility to meet the needs of your specific applications. The options listed above provide a variety of commonly used modifications to satisfy the majority of today's diverse requirements. Should your application require a more unique configuration, please consult your authorized Nailor Representative or the Nailor Industries office nearest you for assistance.

HOW TO SPECIFY OR TO ORDER

MODELS: 1010/1020 WITH OPTIONAL 13 GA. FRAME

HOW TO ORDER:

Standard construction for models 1010/1020 WITH OPTIONAL 13 GA. FRAME is shown in highlighted box. Option codes are listed below. See previous page for description of options.

MODEL	SIZE (W X H)	MATERIAL		FRAME TYPE	FRAME GAUGE	BLADE LINKAGE STYLE	DRIVE LOCATION	BEARINGS	BLADE SEAL	JAMB SEAL	ROUND/OVAL TRANSITION	OPERATOR ACCESSORIES
1010	ie: 48 x 24	GLV	HC	13G	LC	DR/DL	BC	BPV	JSM	-	-	
1020			FF FR FD	↑	LF		BO BS BT		JSS	CR CO	HLQ FMO FMI PCE PCI JK5 JK1 VCK	

- Notes: 1. ↑ Arrow indicates 'must select' option.
 2. Right hand driveshaft is standard. For left hand driveshaft simply rotate the damper so that the driveshaft is on left hand side, as blade and jamb seals are designed to work with airflow in either direction. 1/2" (13) or 1" (25) dia. jackshaftering is standard on all multiple section wide units.
 3. If Pull Chain Operator option is selected, please specify length of chain required.
 4. If Option CR Round Transition casing (or CO) is selected please order by duct size diameter ie: 36"ø.

SUGGESTED SPECIFICATION:

Provide and install, as shown on plans and/or schedules, low-leakage dampers meeting or exceeding the following criteria: Frame shall be constructed of 13 ga. (2.4) galvanized steel hat channel with die-formed corner gussets, fully welded for rigidity. Blades shall be of triple-vee design, 16 ga. (1.6) galvanized steel, on maximum 6" (152) centers, in parallel or opposed (please select) configuration. Blade axles shall be 1/2" (13) dia. plated steel, double thru-bolted to blade at each end. Hex or square friction-fit, or press-fit axles are not acceptable. Bearings shall be Celcon® molded synthetic type. Blade linkage shall be zero-maintenance, out of airstream and totally concealed within the frame. Jackshafts shall be supplied on all multiple section wide assemblies in order to evenly distribute torque. Blade seals shall be dual durometer bulb type extruded PVC, and jamb seals shall be compression type cambered metal, providing positive shut-off. All submitted performance data to be based on tests in accordance with AMCA Standard 500-D. Standard of acceptance: Nailor Industries Model 1010 WITH 13G FRAME (parallel blade) or Model 1020 WITH 13G FRAME (opposed blade).

- STAINLESS STEEL CONSTRUCTION
- VEE BLADE
- LOW LEAKAGE
- STANDARD PERFORMANCE

MODELS:

- 1010-304 STAINLESS STEEL CONSTRUCTION (PARALLEL BLADE)**
- 1020-304 STAINLESS STEEL CONSTRUCTION (OPPOSED BLADE)**



Model 1020 with 304 Stainless Steel construction

Nailor Models 1010/1020 with optional 304 Stainless Steel construction provide an enduring solution for corrosive environment commercial and industrial HVAC and process applications. The proven triple-vee blade design and sturdy hat channel mitered frame with die-formed corner gussets afford solid performance that will withstand many normally harsh atmospheric and process elements. The design also features stainless steel zero-maintenance concealed blade linkage for reduced pressure drop and turbulence, and stainless steel axles, bushings and hardware for long lasting operation suitable for use in applications with temperatures ranging from -50°F (-45°C) to 250°F (121°C) depending on blade configuration and leakage (seals) requirements.

B CONTROL DAMPERS

STANDARD CONSTRUCTION:

- FRAME:** 5" x 7/8" x 16 ga. (127 x 22 x 1.6) Type 304 stainless steel hat channel with stainless steel corner gussets. Frame and corner gussets are welded for rigidity. Low profile (flat top and bottom) on dampers 10" (254) high and under.
- BLADES:** 6" (152) wide on 5 1/2" (140) centers. 16 ga. (1.6) Type 304 stainless steel triple-vee design. Parallel or opposed action.
- LINKAGE:** Concealed type totally enclosed within the frame and out of the airstream. Type 304 stainless steel.
- BEARINGS:** 1/2" (13) dia. Type 304 stainless steel.
- AXLES:** 1/2" (13) dia. stainless steel double bolted to blades.
- DRIVE SHAFT:** 6" (152) long x 1/2" (13) dia. stainless steel rigid shaft; or optional lock-on shaft with outboard support bracket (standard in Canada), on all single section dampers. A 1/2" (13) or 1" (25) dia. factory installed jackshaft is standard on all multiple section dampers.
- BLADE SEALS:** Dual durometer bulb type extruded PVC.
- JAMB SEALS:** Compression type cambered stainless steel.
- MINIMUM SIZE:** Single blade (parallel): 6" x 4" (152 x 102). Two blades (parallel or opposed): 6" x 10" (152 x 254).
- MAXIMUM SIZE:** Single section: 48" x 72" (1220 x 1829). Multiple section assembly - unlimited.

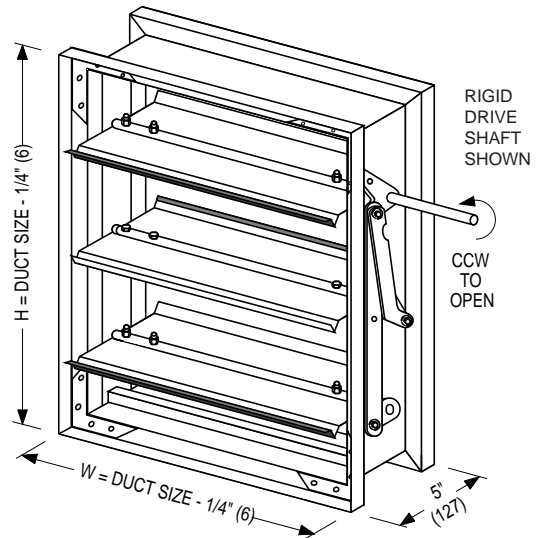

MODEL 1010-304 STAINLESS STEEL PARALLEL BLADE

MODEL 1020-304 STAINLESS STEEL OPPOSED BLADE

† jackshaft standard on multiple section dampers.

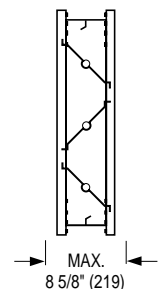
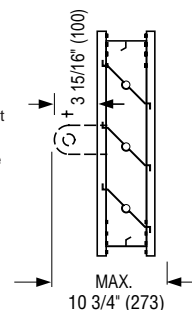

MODELS: 1010/1020 WITH OPTIONAL 304 STAINLESS STEEL CONSTRUCTION

PERFORMANCE DATA:

PRESSURE DROP (damper fully open)

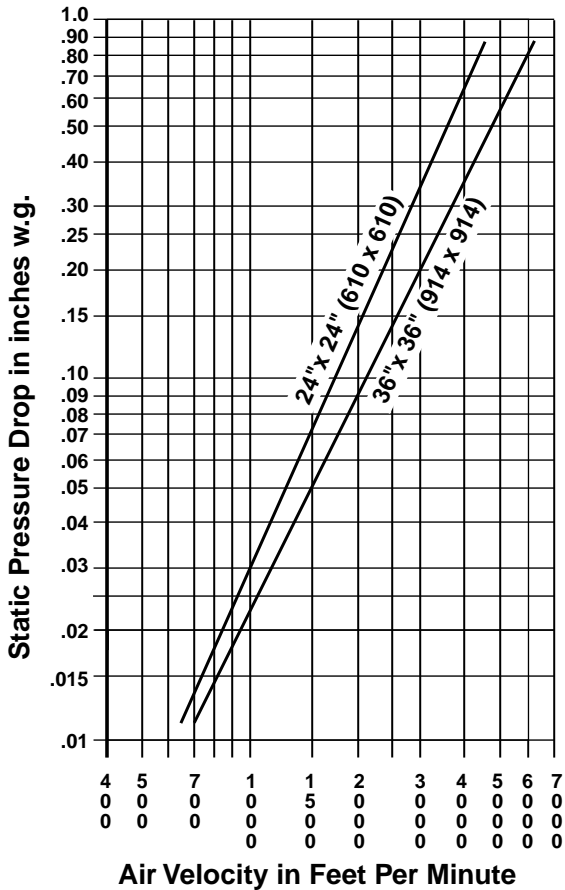

Tested per AMCA standard 500-D, Fig. 5.3.

LEAKAGE (damper fully closed)

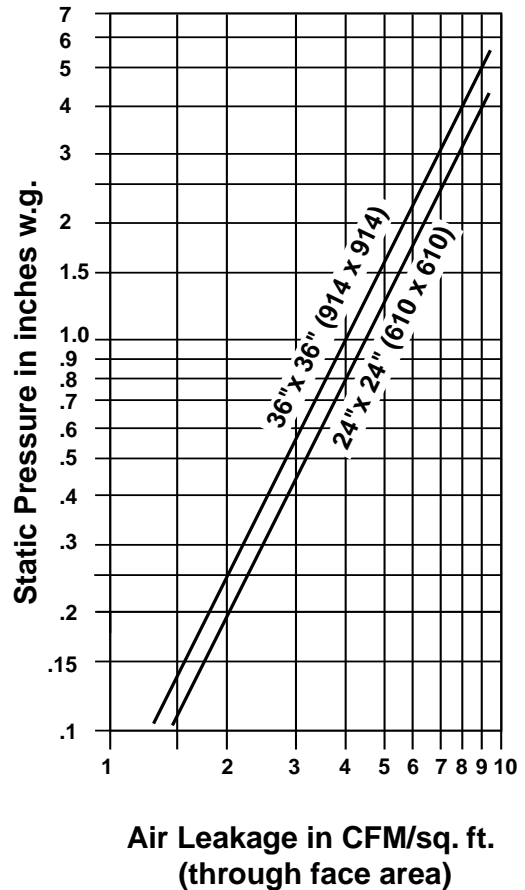

Tested per AMCA standard 500-D, Fig. 5.5.

PRESSURE DROP (in. w.g.)

DAMPER SIZE	APPROACH VELOCITY (FPM)			
	750	1000	1500	2000
24" x 24" (610 x 610)	.016	.030	.07	.14
36" x 36" (914 x 914)	.013	.023	.05	.09
48" x 48" (1219 x 1219)	.010	.020	.03	.07

Tested per AMCA standard 500-D, Fig. 5.3.

DYNAMIC LIMITATIONS/LEAKAGE

DAMPER WIDTH	MAXIMUM SYSTEM PRESSURE	MAXIMUM SYSTEM VELOCITY	LEAKAGE *	
			% OF MAX. FLOW	CFM/SQ. FT.
48" (1219)	2.5" w.g.	2000 FPM	0.18	3.5
36" (914)	3.0" w.g.	2000 FPM	0.20	4.0
24" (610)	4.0" w.g.	2000 FPM	0.23	4.5
12" (305)	5.0" w.g.	2000 FPM	0.33	6.6

* Leakage information is based upon a pressure differential of 1" w.g. tested per AMCA standard 500-D, Fig. 5.5.

Standard Construction Temperature Range: -50°F to 180°F (-45°C to 82°C)

MODELS: 1010/1020 WITH OPTIONAL 304 STAINLESS STEEL CONSTRUCTION

AVAILABLE OPTIONS/ACCESSORIES:

The following construction options and accessories are implemented or available on Models 1010/1020 WITH OPTIONAL 304 STAINLESS STEEL CONSTRUCTION. See page B55 for further description of options/accessories.

	CODE	DESCRIPTION
MATERIAL:	304	Type 304 Stainless Steel Construction.
FRAME:	HC	Hat channel frame is standard. Flange frames are not available with 304 option.
FRAME GAUGE:	16G	16 Gauge frame is standard. Other gauges are not available with 304 option.
BLADE LINKAGE STYLE:	LC	Concealed linkage is standard. Face linkage is not available with 304 option.
BEARINGS:	BS	Stainless Steel Bearings are standard when option 304 is selected.
JAMB SEAL:	JSS	Stainless Steel Jamb Seal is standard when option 304 is selected.
ROUND/OVAL TRANSITION:	CR CO	Transition Casing for Round Duct Transition Casing for Oval Duct
OPERATOR ACCESSORIES:	HLQ PCE PCI FMO FMI JK5 JK1 VCK	Hand Locking Quadrant External Chain Operator Internal Chain Operator Factory Mounted Actuator-Outside w/side plate Factory Mounted Actuator-Internal w/jackshaft 1/2" (13) Dia. Jackshafting for Single Section 1" (25) Dia. Jackshafting for Single Section Vertical Interconnection Kit

B

CONTROL DAMPERS

At Nailor Industries, we take pride in our flexibility to meet the needs of your specific applications. The options listed above provide a variety of commonly used modifications to satisfy the majority of today's diverse requirements. Should your application require a more unique configuration, please consult your authorized Nailor Representative or the Nailor Industries office nearest you for assistance.

HOW TO SPECIFY OR TO ORDER

MODELS: 1010/1020 WITH OPTIONAL 304 STAINLESS STEEL CONSTRUCTION

HOW TO ORDER:

Standard construction for Models 1010/1020 WITH OPTIONAL 304 STAINLESS STEEL CONSTRUCTION is shown in highlighted box. Other option codes are listed below. See previous page for description of options.

MODEL	SIZE (W X H)	MATERIAL	FRAME TYPE	FRAME GAUGE	BLADE LINKAGE STYLE	DRIVE LOCATION	BEARINGS	BLADE SEAL	JAMB SEAL	ROUND/OVAL TRANSITION	OPERATOR ACCESSORIES
1010	ie: 48 x 24	304	HC	16G	LC	DR/DL	BS	BPV	JSS	–	–
1020		↑					*		*	CR CO	HLQ FMO FMI PCE PCI JK5 JK1 VCK

- Notes:
- ↑ Arrow indicates 'must select' option.
 - * When material option 304 is selected, stainless steel bearings (BS) and stainless steel jamb seals (JSS) will be selected automatically.
 - Right hand driveshaft is standard. For left hand driveshaft simply rotate the damper so that the driveshaft is on left hand side, as blade and jamb seals are designed to work with airflow in either direction. 1/2" (13) or 1" (25) dia. jackshafting is standard on all multiple section wide units.
 - If Pull Chain Operator option is selected, please specify length of chain required.
 - If Option CR Round Transition casing (or CO) is selected please order by duct size diameter ie: 36"ø.

SUGGESTED SPECIFICATION:

Provide and install, as shown on plans and/or schedules, low-leakage stainless steel dampers meeting or exceeding the following criteria: Frame shall be constructed of 16 ga. (1.6) Type 304 stainless steel hat channel with mitered corners and stainless steel corner gussets, welded for rigidity. Blades shall be of triple-vee design, 16 ga. (1.6) Type 304 stainless steel construction, on maximum 6" (152) centers, in parallel or opposed (please select) configuration. Blade axles shall be 1/2" (13) dia. stainless steel, double thru-bolted to blades with stainless steel fasteners at each end. Hex or square friction-fit, or press-fit axles are not acceptable. Bearings shall be of Type 304 stainless steel. Blade linkage shall be of Type 304 stainless steel, and be zero-maintenance design, out of airstream and totally concealed within the frame. Blade seals shall be dual durometer bulb type extruded PVC, and jamb seals shall be compression type cambered stainless steel, providing positive shut-off. All submitted performance data to be based on tests in accordance with AMCA Standard 500-D. Standard of acceptance: Nailor Industries Model 1010-304 Stainless Steel (parallel blade) or Model 1020-304 Stainless Steel (opposed blade).

- VEE BLADE
- STANDARD PERFORMANCE
- UNSEALED
- GALVANIZED STEEL

MODELS:

- 1012 PARALLEL BLADE**
- 1022 OPPOSED BLADE**

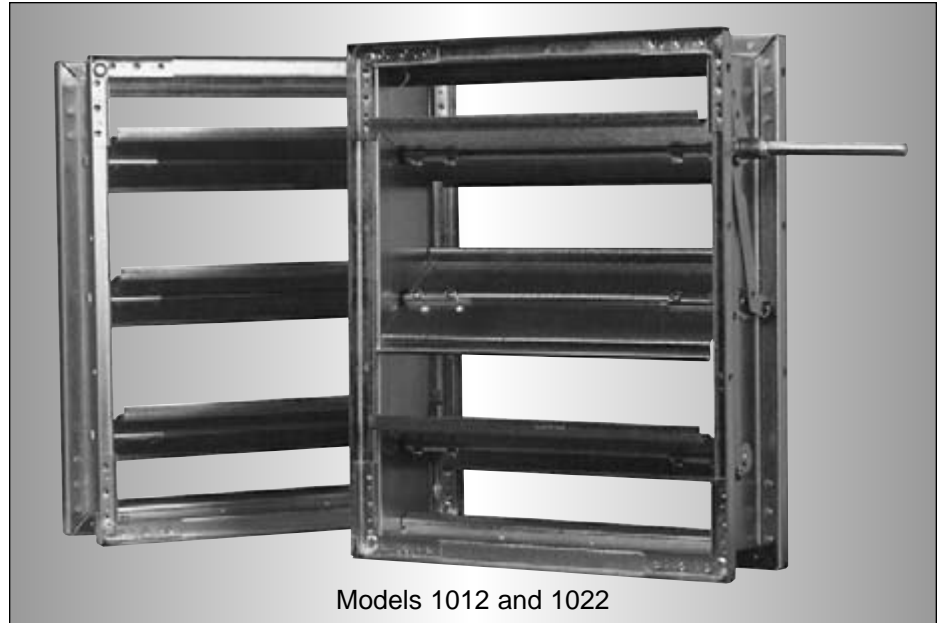

Models 1012 and 1022

The 1012/1022 Series are Nailor's most widely used unsealed dampers and are the standard choice for use in the majority of low to medium pressure and velocity commercial HVAC systems. They are low cost, high quality dampers that meet or exceed the majority of standard specification requirements. The design features include a sturdy hat channel frame with die-formed corner gussets for reinforcement and structural strength equivalent to 13 gauge channel type frames, a triple-vee blade design that maximizes strength and zero maintenance concealed linkage (out of the air stream) for reduced pressure drop and air turbulence.

B CONTROL DAMPERS

STANDARD CONSTRUCTION:

- FRAME:** 5" x 7/8" x 16 ga. (127 x 22 x 1.6) galvanized steel hat channel with die-formed corner gussets. Low profile (flat top and bottom) on dampers 10" (254) high and under.
- BLADES:** 6" (152) wide on 5 1/2" (140) centers. 16 ga. (1.6) galvanized steel triple-vee design. Parallel or opposed action.
- LINKAGE:** Concealed type totally enclosed within the frame and out of the airstream. Plated steel.
- BEARINGS:** 1/2" (13) dia. Celcon®.
- AXLES:** 1/2" (13) dia. plated steel double bolted to blades.
- DRIVE SHAFT:** 6" (152) long x 1/2" (13) dia. rigid shaft; or optional lock-on shaft with outboard support bracket (standard in Canada), on all single section dampers. A 1/2" (13) or 1" (25) dia. factory installed jackshaft is standard on all multiple section dampers.
- MINIMUM SIZE:** Single blade (parallel): 6" x 4" (152 x 102).
Two blades (parallel or opposed): 6" x 10" (152 x 254).
- MAXIMUM SIZE:** Single section: 48" x 72" (1220 x 1829).
Multiple section assembly - unlimited.

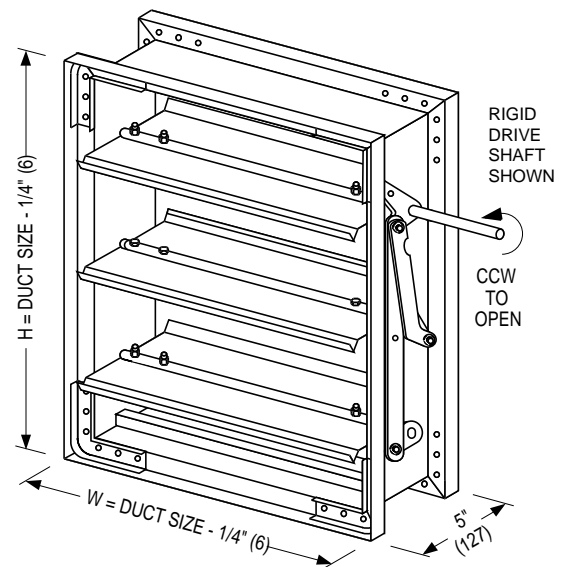

MODEL 1012
PARALLEL BLADE

MODEL 1022
OPPOSED BLADE

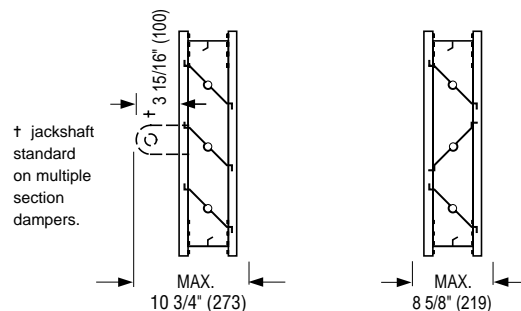

MODELS: 1012/1022

PERFORMANCE DATA:

PRESSURE DROP (damper fully open)

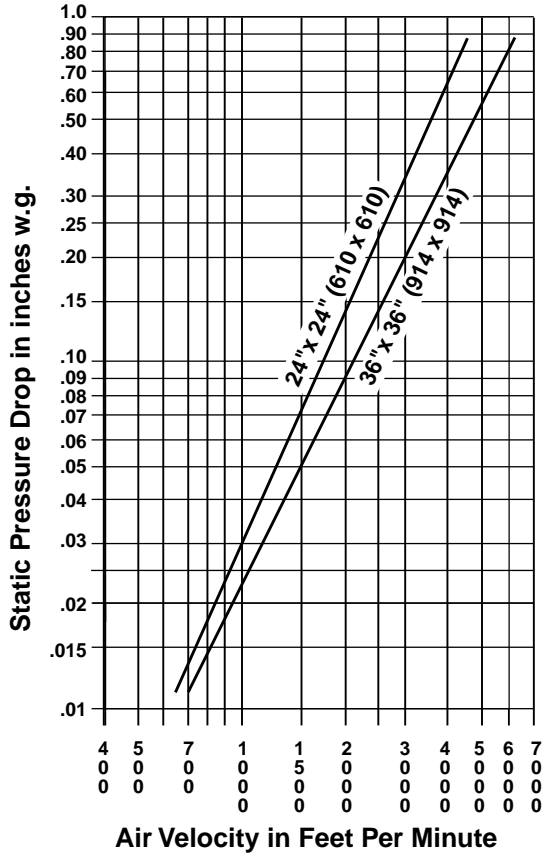

Imperial figures shown.
To convert to SI (metric) system:
 Multiply:
 CFM x .4719 = liters per second
 inches w.g. x .2486 = kilopascals
 fpm x .00508 = meters per second
 cfm per sq. ft. x 5.08 = liters/second per sq. meter.

LEAKAGE (damper fully closed w/o seals)

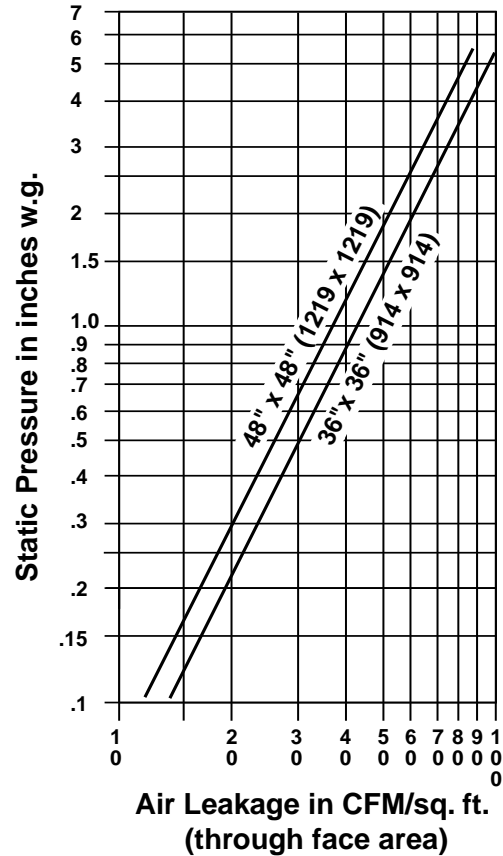

Tested per AMCA standard 500-D, Fig. 5.5.

B CONTROL DAMPERS

PRESSURE DROP (in. w.g.)

DAMPER SIZE	APPROACH VELOCITY (FPM)			
	750	1000	1500	2000
24" x 24" (610 x 610)	.016	.030	.07	.14
36" x 36" (914 x 914)	.013	.023	.05	.09
48" x 48" (1219 x 1219)	.010	.020	.03	.07

Tested per AMCA standard 500-D, Fig. 5.3.

DYNAMIC LIMITATIONS / LEAKAGE

DAMPER WIDTH	MAXIMUM SYSTEM PRESSURE	MAXIMUM SYSTEM VELOCITY	LEAKAGE *			
			W/O SEALS		W/SEALS	
			% OF MAX. FLOW	CFM/ SQ. FT.	% OF MAX. FLOW	CFM/ SQ. FT.
48" (1219)	2.5" w.g.	2000 FPM	1.90	38	0.48	9.5
36" (914)	3.0" w.g.	2000 FPM	2.15	43	0.54	10.8
24" (610)	4.0" w.g.	2000 FPM	2.35	47	0.57	11.3
12" (305)	5.0" w.g.	2000 FPM	3.10	62	0.80	16.0

* Leakage information is based upon a pressure differential of 1" w.g. tested per AMCA standard 500-D, Fig. 5.5.

Temperature Range: -50°F to 180°F (-45°C to 82°C)

MODELS: 1012/1022

AVAILABLE OPTIONS/ACCESSORIES:

The following construction options and accessories are available on Models 1012/1022. See page B55 for further description of options/accessories.

	CODE	DESCRIPTION
MATERIAL:	304 ALS	Stainless Steel Construction Aluminum Construction With Stainless Steel Hardware
FRAME:	FR/FRB FD/FDB FF/FFB	Rear Flange/Rear Flange With Bolt Holes Double Flange/Double Flange With Bolt Holes Front Flange/Front Flange With Bolt Holes
FRAME GAUGE:	14G 13G 12G	14 Gauge 13 Gauge 12 Gauge
BLADE LINKAGE STYLE:	LF	Face Linkage
BEARINGS:	BO BS BT	Oilite® Bronze Bearings Stainless Steel Bearings Thrust Bearings
BLADE SEAL:	BSP	Polyurethane Foam Blade Seals
JAMB SEAL:	JSM	Compression Type Cambered Metal
ROUND/OVAL TRANSITION:	CR CO	Transition Casing for Round Duct Transition Casing for Oval Duct
OPERATOR ACCESSORIES:	HLQ PCE PCI FMO FMI JK5 JK1 VCK	Hand Locking Quadrant External Chain Operator Internal Chain Operator Factory Mounted Actuator-Outside w/side plate Factory Mounted Actuator-Internal w/jackshaft 1/2" (13) Dia. Jackshafting for Single Section 1" (25) Dia. Jackshafting for Single Section Vertical Interconnection Kit

B

CONTROL DAMPERS

At Nailor Industries, we take pride in our flexibility to meet the needs of your specific applications. The options listed above provide a variety of commonly used modifications to satisfy the majority of today's diverse requirements. Should your application require a more unique configuration, please consult your authorized Nailor Representative or the Nailor Industries office nearest you for assistance.

HOW TO SPECIFY OR TO ORDER

MODELS: 1012/1022

HOW TO ORDER:

Standard construction is shown in highlighted box. Option codes are listed below. See previous page for description of options.

MODEL	SIZE (W X H)	MATERIAL	FRAME TYPE	FRAME GAUGE	BLADE LINKAGE STYLE	DRIVE LOCATION	BEARINGS	BLADE SEAL	JAMB SEAL	ROUND/OVAL TRANSITION	OPERATOR ACCESSORIES
1012	ie: 48 x 24	GLV	HC	16G	LC	DR/DL	BC	-	-	-	-
1022		304 ALS	FF FFB FR FRB FD FDB	14G 13G 12G	LF		BO BS BT	BSP	JSM	CR CO	HLQ FMO FMI PCE PCI JK5 JK1 VCK

- Notes:
1. 1/2" (13) or 1" (25) dia. jackshifting is standard on all multiple section wide units.
 2. If Pull Chain Operator option is selected, please specify length of chain required.
 3. If Option CR Round Transition casing (or CO) is selected please order by duct size diameter ie: 36"Ø.

SUGGESTED SPECIFICATION:

Provide and install, as shown on plans and/or schedules, control dampers meeting or exceeding the following criteria: Frame shall be constructed of 16 ga. (1.6) galvanized steel hat channel with mitered corners and die-formed corner gussets for rigidity and structural strength equivalent to 13 ga. (2.4) channel type frames. Blade shall be of triple-vee design, 16 ga. (1.6) galvanized steel, on maximum 6" (152) centers, in parallel or opposed (please select) configuration. Blade axles shall be 1/2" (13) dia. plated steel, double thru-bolted to blade at each end. Hex or square friction-fit, or press-fit axles are not acceptable. Bearings shall be Celcon® molded synthetic type. Blade linkage shall be zero-maintenance, out of airstream and totally concealed within the frame. Jackshafts shall be supplied on all multiple section wide assemblies in order to evenly distribute torque. Standard of acceptance: Nailor Industries Model 1012 (parallel blade) or Model 1022 (opposed blade).

For CR Round Transition Option, add the following:

Damper shall be provided with a 20 ga. (1.0) galvanized steel casing for sizes up to 36" (914) dia., 18 ga. (1.31) for larger sizes, complete with round collar on both sides. Casing shall be welded and caulked against leakage. Standard of acceptance: Nailor Industries Model 1012CR (parallel blade) or Model 1022CR (opposed blade).

- FOR ROUND DUCT
- LOW LEAKAGE
- GALVANIZED STEEL

MODEL: 1090

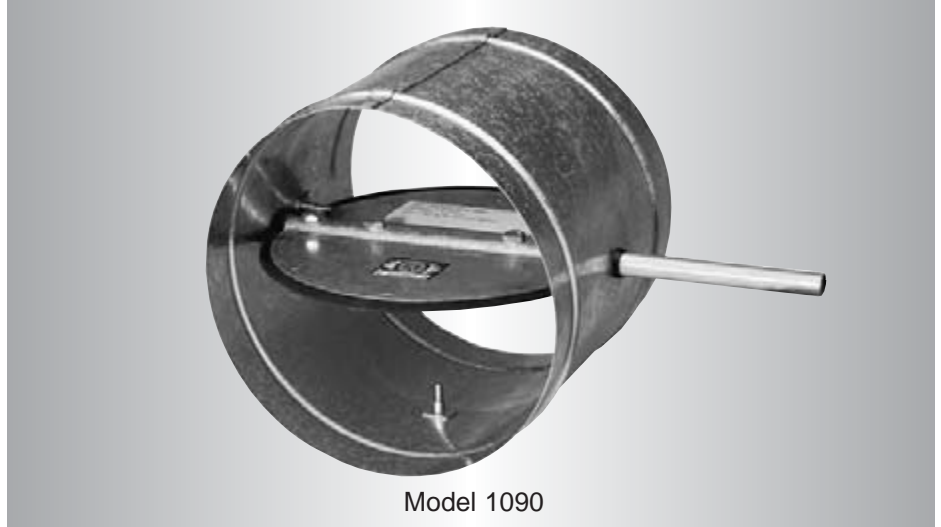

Model 1090

The Nailor Model 1090 is a low leakage, butterfly damper which has been designed for all types of round ductwork applications and is suitable for use in the majority of low to medium pressure and velocity commercial HVAC systems. The design features a sturdy beaded casing for superior rigidity and a laminated blade double bolted to axle and drive shaft for maximum strength. The 1090 installs easily in round spiral ductwork. The damper may be used for two position or modulating control using a variety of electric or pneumatic actuators or may also be used as a manual balancing damper when used with the optional hand locking quadrant and positive shut-off is required.

B

CONTROL DAMPERS

STANDARD CONSTRUCTION:

- FRAME:** 22 ga. (0.86) corrosion-resistant steel with stiffening beads up to 12" (305) dia. 20 ga. (0.91) over 12" (305) dia.
- BLADE:** 2 x 22 ga. (0.86) corrosion-resistant steel laminated together, equivalent to 16 ga. (1.6). Open and close end stops. 90 degree rotation. CCW to open.
- BEARINGS:** Celcon®.
- DRIVE SHAFT/ AXLES:** 1/2" (13) dia. plated steel double bolted to blade. Axle extends approx. 6" (152) beyond frame.
- BLADE SEAL:** Cross-linked polyethylene.
- AVAILABLE SIZES:** 4" (102) through 24" (610) diameter in nominal 1" (25) increments.

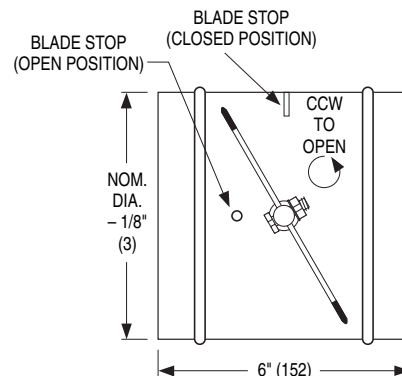
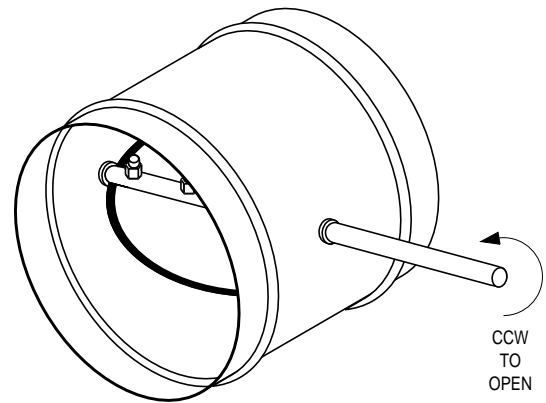

MODEL: 1090

PERFORMANCE DATA:

PRESSURE DROP (damper fully open)

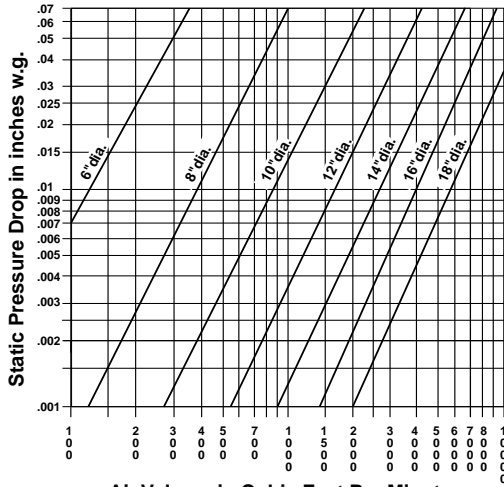

Air Volume in Cubic Feet Per Minute

Tested per AMCA standard 500-D, Fig. 5.3.

Imperial figures shown.
To convert to SI (metric) system:

- Multiply:
- CFM x .4719 = liters per second
- inches w.g. x .2486 = kilopascals
- fpm x .00508 = meters per second
- cfm per sq. ft. x 5.08 = liters/second per sq. meter.

AIR LEAKAGE (damper closed)

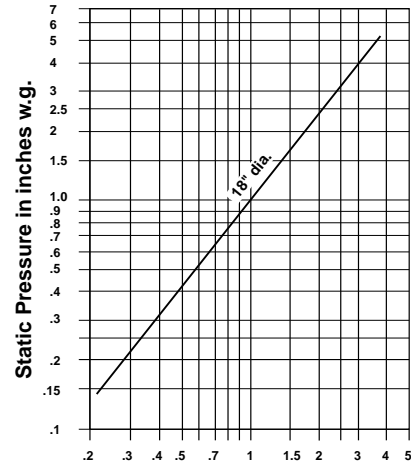

Air Leakage in CFM/sq. ft. (through face area)

Tested per AMCA standard 500-D, Fig. 5.5.

Temperature Range: -50°F to 180°F (-45°C to 82°C)

AVAILABLE OPTIONS/ACCESSORIES:

The following construction options and accessories are available on Model 1090. See page B55 for detailed description of options/accessories.

	CODE	DESCRIPTION
MATERIAL:	304	304 Stainless Steel Construction
BEARINGS:	BO BS	Oilite® Bronze Bearings Stainless Steel Bearings
ACTUATORS/ MANUAL QUADRANTS:	411 811 482 HLQ HL2	ML4115 Honeywell-120V ML8115 Honeywell-24V 331-4826 Siemens-25 psi Manual Locking Quadrant with 7/8" (22) stand-off bracket. Manual Locking Quadrant with 2" (51) stand-off bracket

At Nailor Industries, we take pride in our flexibility to meet the needs of your specific applications. The options listed above provide a variety of commonly used modifications to satisfy the majority of today's diverse requirements. Should your application require a more unique configuration, please consult your authorized Nailor Representative or the Nailor Industries office nearest you for assistance.

HOW TO SPECIFY OR TO ORDER

MODEL: 1090

HOW TO ORDER:

Standard construction is shown in highlighted box. Option codes are listed below. See previous page for description of options.

MODEL	SIZE Ø	MATERIAL	BEARINGS	ACTUATORS/ MANUAL QUADS.
1090	ie: 12" dia	GLV	BC	-
		304	BO BS	411 811 482 HLQ HL2

SUGGESTED SPECIFICATION:

Provide and install, as shown on plans and/or schedules, low leakage round dampers meeting or exceeding the following criteria: Frame shall be constructed of 22 ga. (0.86) corrosion resistant steel with roll-formed stiffening beads up to 12" (305) dia.; 20 ga. (0.91) over 12" (305) dia.. Blade shall be 2 x 22 ga. (0.86) corrosion resistant steel laminated together, equivalent to 16 ga. (1.6). Open and closed end-stops shall provide maximum 90° rotation. Bearings shall be Celcon® molded synthetic type. Blade axle/drive shaft shall be 1/2" (13) dia. plated steel double bolted to blade. Hex or square friction-fit, or press-fit axles are not acceptable. Blade seal shall be cross-linked polyethylene sandwiched in blade. Submitted performance data shall show leakage of less than 10 cfm/sq. ft. @ 4" w.g. (0.05 m³/s/m² @ 1 kPa). Standard of acceptance: Nailor Industries Model 1090.

Notes:

B

CONTROL DAMPERS

AMCA
LICENSED

- AIRFOIL BLADE
- HIGH PERFORMANCE
- ULTRA-LOW LEAKAGE
- GALVANIZED STEEL

MODELS:

- 1110 PARALLEL BLADE
- 1120 OPPOSED BLADE



Models 1110 and 1120

The 1110/1120 Series are Nailor's most cost effective steel airfoil blade control dampers. The ultra-low leakage (Class 1A) dampers are suitable for use in the majority of low to medium pressure and velocity commercial HVAC systems. They are suitable for use in the majority of low to medium pressure and velocity commercial HVAC systems.

The design features include a sturdy hat channel frame with die-formed corner gussets for reinforcement and structural strength equivalent to 13 gauge channel type frames and zero maintenance concealed linkage (out of the air stream) for reduced pressure drop and air turbulence. Models 1110 and 1120 are AMCA Licensed and meet the IEC Code (802.3.4) maximum leakage for building envelope dampers criteria of 3 cfm/ft² @ 1" w.g. (15.2 l/s/m² @ 0.25 kPa).

B CONTROL DAMPERS

STANDARD CONSTRUCTION:

- FRAME:** 5" x 7/8" x 16 ga. (127 x 22 x 1.6) galvanized steel hat channel with die-formed corner gussets. Low profile (flat top and bottom) on dampers 10" (254) high and under.
- BLADES:** 6" (152) wide on 5 1/2" (140) centers. 2 x 20 ga. (1.0) galvanized steel formed into an airfoil cross-section. 14 ga. (2.0) equivalent thickness. Parallel or opposed action.
- LINKAGE:** Concealed side type totally enclosed within the frame and out of the air stream. Plated steel.
- BEARINGS:** 1/2" (13) dia. Oilite® self-lubricating bronze.
- AXLES:** 1/2" (13) dia. plated steel double bolted to blades.
- DRIVE SHAFT:** 6" (152) long x 1/2" (13) dia. rigid shaft; or optional lock-on shaft with outboard support bracket (standard in Canada), on all single section dampers. A 1/2" (13) or 1" (25) dia. factory installed jackshaft is standard on all multiple section wide dampers.
- BLADE SEALS:** Extruded PVC.
- JAMB SEALS:** Cambered stainless steel.
- MINIMUM SIZE:** Single blade (parallel) 6" x 6" (152 x 152). Two blades (parallel or opposed) 6" x 10" (152 x 254).
- MAXIMUM SIZE:** Single section size is 48" x 72" (1219 x 1829). Multiple section - unlimited.

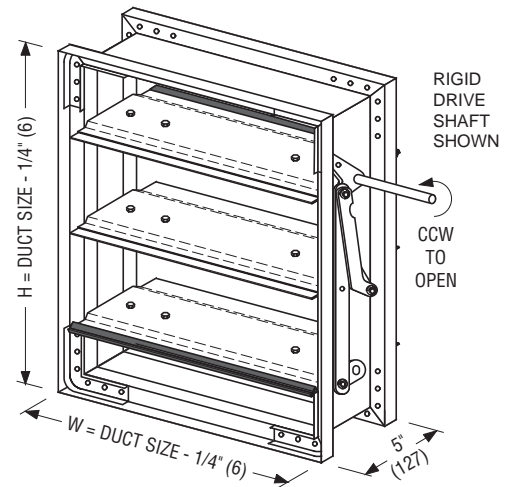

MODEL 1110
PARALLEL BLADE

MODEL 1120
OPPOSED BLADE

† jackshaft standard on multiple section dampers. Jackshaft securely bolted to frame.

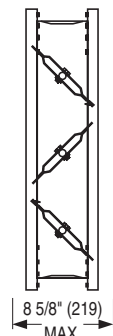
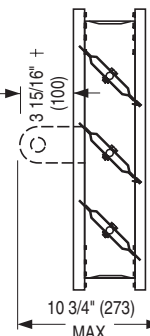

MODELS: 1110/1120 PERFORMANCE DATA:

PERFORMANCE LIMITATIONS:

DAMPER WIDTH		MAXIMUM SYSTEM PRESSURE	MAXIMUM SYSTEM VELOCITY
IN.	MM		
48	1219	8.0" w.g.	4000 FPM
36	914	10.0" w.g.	4500 FPM
24	610	12.0" w.g.	5000 FPM
12	305	14.0" w.g.	6000 FPM

The 1100 Series with its standard maximum single section and multiple section sizing limitation may be used in applications with system pressures of up to 8.0" w.g.. The 1100 Series may also be used in systems with higher total pressures by reducing the damper section width as shown in the table.

Temperature Range: -50°F to 180°F (-45°C to 82°C)



Nailor Industries Inc. certifies that the Models 1110 and 1120 Dampers shown herein are licensed to bear the AMCA seal. The ratings shown are based on tests and procedures performed in accordance with AMCA Publication 511 and comply with the requirements of the AMCA Certified Ratings Program. The AMCA Certified Ratings Seal applies to air leakage ratings and air performance ratings.

LEAKAGE CLASS:

DAMPER WIDTH	@ 1" w.g. (0.25 kPa)	@ 4" w.g. (1.0 kPa)
12" (305)	1A	1A
24" (610)	1A	1A
36" (914)	1A	1A
48" (1219)	1A	1A

Maximum leakage permitted for Class rating is as follows:

Class 1A: 3 cfm/sq. ft. @ 1" w.g. (15.2 l/s/m² @ 0.25 kPa)

8 cfm/sq. ft. @ 4" w.g. (40.6 l/s/m² @ 1.0 kPa)

Leakage tested in accordance with AMCA Standard 500-D-98. Data based on a torque of 7" lbs./sq. ft. (minimum 20" lbs.) applied to hold the damper in closed position. Leakage class is based on operation between 50°F and 104°F (10°C and 40°C). Data corrected to standard air density of 0.075 lbs/ft³.

B

CONTROL DAMPERS

PRESSURE DROP:

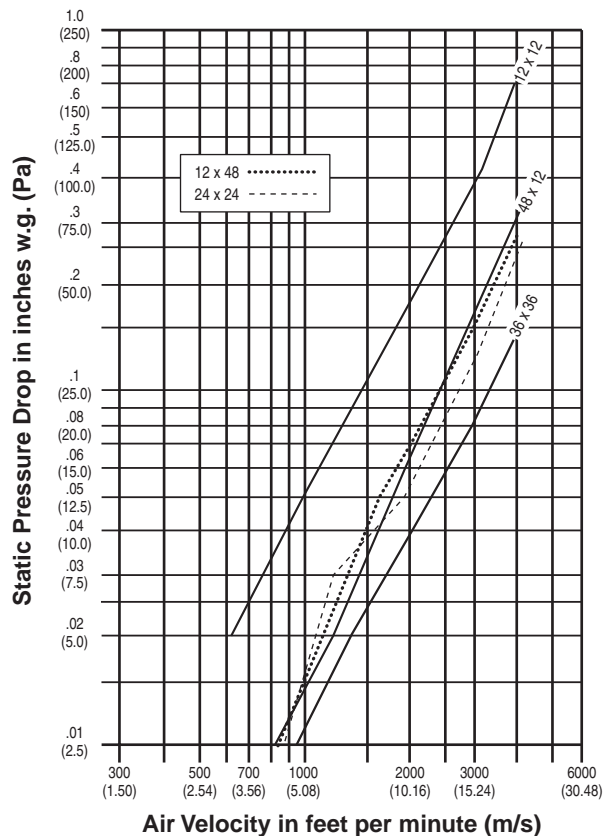

Pressure drop tested per AMCA Standard 500-D-98, Figure 5.3. Data corrected to standard air density of 0.075 lbs/ft³.

Size: 12 x 12 (305 x 305)

VELOCITY fpm (m/s)	PRESSURE DROP in. w.g. (Pa)
627 (3.19)	.02 (5)
997 (5.07)	.05 (12)
2005 (10.19)	.18 (45)
3013 (15.31)	.41 (102)
3955 (20.09)	.70 (174)

Size: 24 x 24 (610 x 610)

VELOCITY fpm (m/s)	PRESSURE DROP in. w.g. (Pa)
889 (4.52)	.01 (2)
1242 (6.31)	.03 (7)
1938 (9.85)	.05 (12)
3068 (15.59)	.13 (32)
4336 (22.03)	.26 (65)

Size: 36 x 36 (914 x 914)

VELOCITY fpm (m/s)	PRESSURE DROP in. w.g. (Pa)
954 (4.84)	.01 (2)
1366 (6.94)	.02 (5)
2030 (10.32)	.04 (10)
2987 (15.18)	.08 (20)
3955 (20.09)	.14 (35)

Size: 48 x 12 (1219 x 305)

VELOCITY fpm (m/s)	PRESSURE DROP in. w.g. (Pa)
867 (4.41)	.01 (2)
1229 (6.25)	.02 (5)
1948 (9.90)	.06 (15)
3084 (15.67)	.17 (42)
4330 (22.00)	.33 (85)

Size: 12 x 48 (305 x 1219)

VELOCITY fpm (m/s)	PRESSURE DROP in. w.g. (Pa)
869 (4.42)	.01 (2)
1662 (8.45)	.05 (12)
2014 (10.23)	.07 (17)
2974 (15.11)	.15 (37)
4012 (20.38)	.27 (67)

MODELS: 1110/1120

AVAILABLE OPTIONS/ACCESSORIES:

The following construction options and accessories are available on Models 1110/1120. See page B55 for detailed description of options/accessories.

	CODE	DESCRIPTION
MATERIAL:	304	Stainless Steel Construction
FRAME:	FR/FRB FD/FDB FF/FFB	Rear Flange/Rear Flange With Bolt Holes Double Flange/Double Flange With Bolt Holes Front Flange/Front Flange With Bolt Holes
FRAME GAUGE:	14G 13G 12G	14 Gauge 13 Gauge 12 Gauge
BEARINGS:	BS BT	Stainless Steel Bearings Thrust Bearings
TRANSITION:	CR CO	Transition Casing for Round Duct Transition Casing for Oval Duct
OPERATOR ACCESSORIES:	HLQ PCE PCI FMO FMI JK5 JK1 VCK	Hand Locking Quadrant External Chain Operator Internal Chain Operator Factory Mounted Actuator-Outside w/ side plate Factory Mounted Actuator-Internal w/ jackshaft 1/2" (13) Dia. Jackshafting for Single Section 1" (25) Dia. Jackshafting for Single Section Vertical Interconnection Kit

B

CONTROL DAMPERS

At Nailor Industries, we take pride in our flexibility to meet the needs of your specific applications. The options listed above provide a variety of commonly used modifications to satisfy the majority of today's diverse requirements. Should your application require a more unique configuration, please consult your authorized Nailor Representative or the Nailor Industries office nearest you for assistance.

HOW TO SPECIFY OR TO ORDER

MODELS: 1110/1120

HOW TO ORDER:

Standard construction is shown in highlighted box. Option codes are listed below. See previous page for description of options.

MODEL	SIZE (W X H)	MATERIAL	FRAME TYPE	FRAME GAUGE	DRIVE LOCATION	BEARINGS	BLADE SEAL	JAMB SEAL	ROUND/OVAL TRANSITION	OPERATOR ACCESSORIES
1110	ie: 48 x 24	GLV	HC	16G	DR/DL	BO	BPV	JSS	-	-
1120		304	FF	14G		BT			CR	HLQ
			FFB	13G		BS			CO	FMO
			FR	12G						FMI
			FRB							PCE
			FD							PCI
			FDB							JK5
										JK1
										VCK

- Notes:
1. 1/2" (13) or 1" (25) dia. jackshafting is standard on all multiple section wide units.
 2. If Pull Chain Operator option is selected, please specify length of chain required.
 3. If Option CR Round Transition casing (or CO) is selected please order by duct size diameter ie: 36"Ø.

SUGGESTED SPECIFICATION:

Provide and install, as shown on plans and/or schedules, ultra-low leakage control dampers meeting or exceeding the following criteria: Frame shall be constructed of 16 ga. (1.6) galvanized steel hat channel with mitered corners and die-formed corner gussets for rigidity and structural strength equivalent to 13 ga. (2.4) channel type frames. Blades shall be 2 x 20 ga. (1.0) galvanized steel formed and welded to produce airfoil design. Blades shall be on maximum 6" (152) centers, in parallel or opposed (please select) configuration. Blade axles shall be 1/2" (13) dia. plated steel, double thru-bolted to blade at each end. Hex or square friction-fit, or press-fit axles are not acceptable. Bearings shall be Oilite® self-lubricating bronze type. Blade linkage shall be zero-maintenance, out of airstream and totally concealed within the frame. Jackshafts shall be supplied on all multiple section assemblies in order to evenly distribute torque. Blade seals shall be extruded PVC, and jamb seals shall be compression type cambered stainless steel, providing positive shut-off. All submitted performance data to be based on tests in accordance with AMCA Standard 500-D. Dampers must comply with the requirements of AMCA 511 Certified Ratings Program and be qualified to bear the AMCA Seal for Air Leakage and Air Performance. Damper widths from 12" to 48" (305 to 1219) shall meet leakage Class 1A criteria of maximum 3 cfm/sq. ft. (15.2 L/s/m²) at 1" w.g. (.25 kPa) and 8cfm/sq. ft. (40.6L/s/m²) at 4" w.g. (1 kPa). Standard of acceptance: Nailor Industries Model 1110 (parallel blade) or Model 1120 (opposed blade).

For CR Round Transition Option, add the following:

Damper shall be provided with a 20 ga. (1.0) galvanized steel casing for sizes up to 36" (914) dia., 18 ga. (1.31) for larger sizes, complete with round collar on both sides. Casing shall be welded and caulked against leakage. Standard of acceptance: Nailor Industries Model 1110CR (parallel blade) or Model 1120CR (opposed blade).

- EXTRUDED ALUMINUM AIRFOIL BLADE
- HIGH PERFORMANCE
- ULTRA-LOW LEAKAGE
- STEEL FRAME

MODELS:

2010 PARALLEL BLADE

2020 OPPOSED BLADE

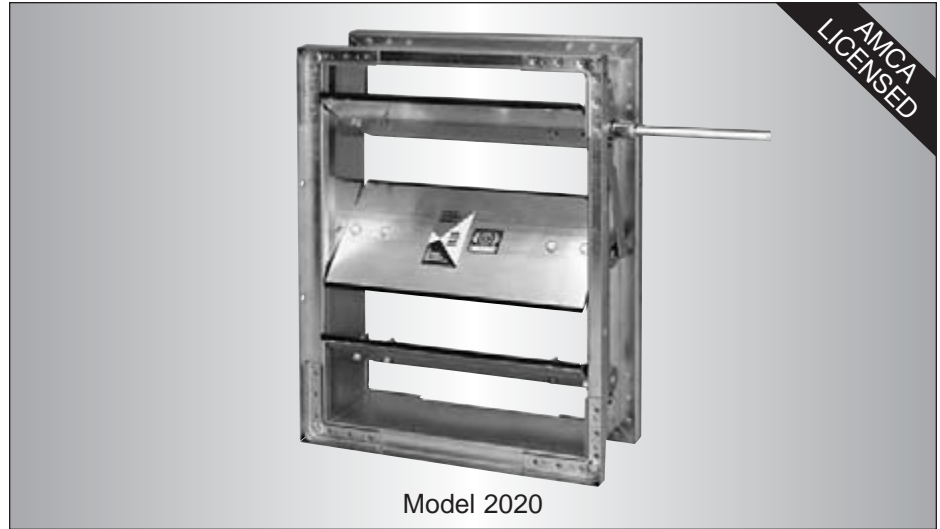

Model 2020

The 2000 Series dampers are Nailor's premium choice for use in high velocity, medium pressure commercial and industrial HVAC systems. They offer unsurpassed leakage and pressure drop characteristics for superior performance that meets the IEC Code maximum leakage for building envelope dampers criteria of 3 cfm/ft.² (15.2 L/s/m²). Model 2020 opposed blade, is an AMCA licensed damper, bearing the AMCA Air Leakage and Air Performance Seal, and provides the ultimate in ultra-low leakage performance characteristics.

Standard features include a rugged galvanized steel hat channel frame with die-formed corner gussets for strength, no-maintenance concealed linkage, and heavy duty extruded aluminum airfoil blades that combine superior rigidity and deflection resistance with low pressure drop. Unique design compression type seals are keyed and locked into blade extrusion, providing the ultimate in ultra-low leakage and high performance.

B

CONTROL DAMPERS

STANDARD CONSTRUCTION:

- FRAME:** 5" x 7/8" x 16 ga. (127 x 22 x 1.6) galvanized steel hat channel with die-formed corner gussets for reinforcement and extra strength.
- BLADES:** Airfoil type 6063-T5 extruded aluminum on 5 1/2" (140) centers.
- LINKAGE:** Concealed side type totally enclosed within the frame and out of the air stream. Plated steel.
- BEARINGS:** 1/2" (13) dia. Oilite® self-lubricating bronze.
- AXLES:** 1/2" (13) dia. plated steel double bolted to blades.
- DRIVE SHAFT:** 6" (152) long x 1/2" (13) dia. rigid drive shaft; or optional lock-on shaft with outboard support bracket (standard in Canada), on all single section dampers. A 1/2" (13) or 1" (25) dia. factory installed jackshaft is standard on all multiple section dampers.
- BLADE SEALS:** Silicone. Mechanically locked in place.
- JAMB SEALS:** Cambered stainless steel.
- MINIMUM SIZE:** Single blade (parallel) 8" x 8" (203 x 203).
Two blades (parallel or opposed) 8" x 12" (203 x 305).
- MAXIMUM SIZE:** Single section size is 60" x 72" (1524 x 1829).
Multiple section - unlimited.

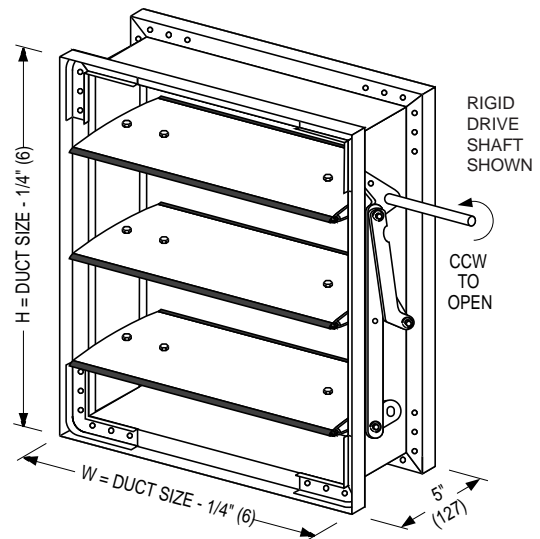

MODEL 2010
PARALLEL BLADE

MODEL 2020
OPPOSED BLADE

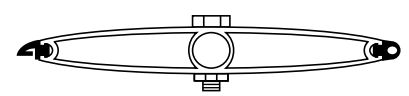
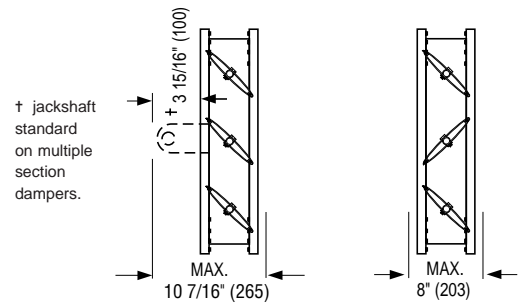

EXTRUDED ALUMINUM AIRFOIL BLADE

MODELS: 2010/2020 PERFORMANCE DATA:

PERFORMANCE LIMITATIONS:

DAMPER WIDTH		MAXIMUM SYSTEM PRESSURE	MAXIMUM SYSTEM VELOCITY
IN.	MM		
60	1524	5.0" w.g.	3000 FPM
48	1219	8.0" w.g.	4000 FPM
36	914	10.0" w.g.	4500 FPM
24	610	12.0" w.g.	5000 FPM
12	305	14.0" w.g.	6000 FPM

The 2000 Series with its standard maximum single section and multiple section sizing limitation may be used in applications with system pressures of up to 5.0" w.g.. The 2000 Series may also be used in systems with higher total pressures by reducing the damper section width as shown in the table.

Temperature Range: -50°F to 250°F (-45°C to 157°C)



Nailor Industries Inc. certifies that the Model 2020 Damper shown herein is licensed to bear the AMCA seal. The ratings shown are based on tests and procedures performed in accordance with AMCA Publication 511 and comply with the requirements of the AMCA Certified Ratings Program. The AMCA Certified Ratings Seal applies to air leakage ratings and air performance ratings. Model 2010 is not licensed to bear the AMCA seal.

LEAKAGE CLASS:

DAMPER WIDTH	@ 1" w.g. (0.25 kPa)	@ 4" w.g. (1.0 kPa)	@ 8" w.g. (2.0 kPa)	@ 12" w.g. (3.0 kPa)
12" (305)	1A	1A	1A	1A
24" (610)	1A	1A	1A	1A
36" (914)	1A	1A	1A	—
48" (1219)	1A	1A	—	—
60" (1524)	1A	1A	—	—

Maximum leakage permitted for Class rating is as follows:

Class 1A: 3 cfm/sq. ft. @ 1" w.g. (15.2 l/s/m² @ 0.25 kPa)

8 cfm/sq. ft. @ 4" w.g. (40.6 l/s/m² @ 1.0 kPa)

11 cfm/sq. ft. @ 8" w.g. (55.9 l/s/m² @ 2.0 kPa)

14 cfm/sq. ft. @ 12" w.g. (71.1 l/s/m² @ 3.0 kPa)

Leakage tested in accordance with AMCA Standard 500-D-98. Data based on a torque of 8" lbs./sq. ft. (minimum 20" lbs.) applied to hold the damper in closed position. Leakage class is based on operation between 50°F and 104°F (10°C and 40°C). Data corrected to standard air density of 0.075 lbs./ft.³

PRESSURE DROP:

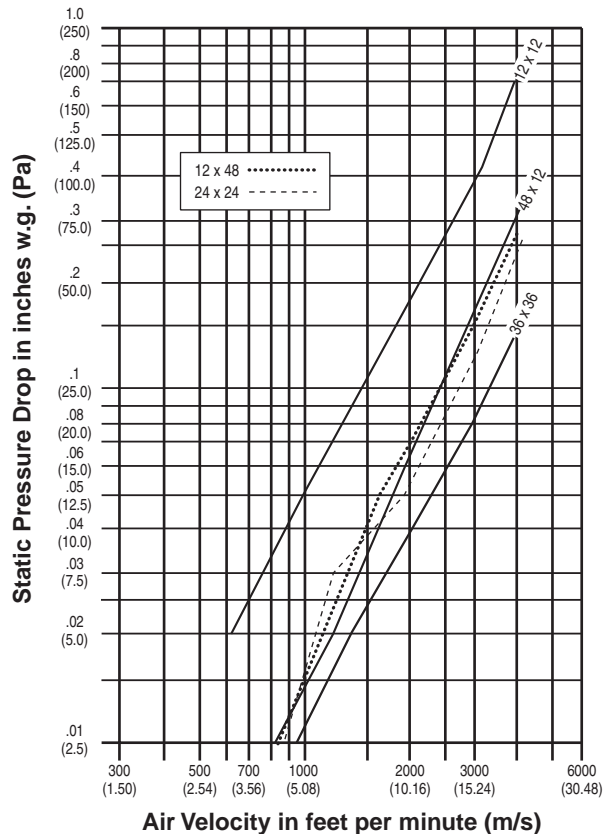

Pressure drop tested per AMCA Standard 500-D-98, Figure 5.3. Data corrected to standard air density of 0.075 lbs./ft.³.

Size: 12 x 12 (305 x 305)

VELOCITY fpm (m/s)	PRESSURE DROP in. w.g. (Pa)
492 (2.50)	.01 (2)
992 (5.04)	.04 (10)
2056 (10.44)	.17 (42)
2994 (15.21)	.35 (87)
3922 (19.93)	.61 (151)

Size: 24 x 24 (610 x 610)

VELOCITY fpm (m/s)	PRESSURE DROP in. w.g. (Pa)
891 (4.53)	.01 (2)
1244 (6.32)	.02 (5)
1942 (9.87)	.04 (10)
3074 (15.62)	.10 (25)
4344 (22.07)	.20 (50)

Size: 36 x 36 (914 x 914)

VELOCITY fpm (m/s)	PRESSURE DROP in. w.g. (Pa)
513 (2.61)	.01 (2)
1087 (5.52)	.01 (2)
1959 (9.95)	.03 (7)
2974 (15.11)	.06 (15)
3922 (19.93)	.12 (30)

Size: 48 x 12 (1219 x 305)

VELOCITY fpm (m/s)	PRESSURE DROP in. w.g. (Pa)
881 (4.48)	.01 (2)
1249 (6.35)	.02 (5)
1950 (9.91)	.04 (10)
3086 (15.68)	.13 (32)
4361 (22.15)	.26 (65)

Size: 12 x 48 (305 x 1219)

VELOCITY fpm (m/s)	PRESSURE DROP in. w.g. (Pa)
869 (4.42)	.01 (2)
1663 (8.45)	.05 (12)
2027 (10.30)	.07 (17)
2935 (14.91)	.15 (37)
4008 (20.36)	.27 (67)

MODELS: 2010/2020

AVAILABLE OPTIONS/ACCESSORIES:

The following construction options and accessories are available on Models 2010/2020. See page B55 for detailed description of options/accessories.

	CODE	DESCRIPTION
FRAME MATERIAL:	EAF SSF	Extruded Aluminum Frame (See Models 2010 EAF/2020 EAF for specific details) Stainless Steel Frame
FRAME TYPE:	FF/FFB FR/FRB FD/FDB	Front Flange/Front Flange with Bolt Holes Rear Flange/Rear Flange with Bolt Holes Double Flange/Double Flange with Bolt Holes Note: Flange Options are not available on EAF or SSF frame styles.
FRAME GAUGE:	14G 13G 12G	14 Gauge 13 Gauge 12 Gauge Note: Frame Gauge Option applies to standard galvanized steel frame only.
BLADE LINKAGE:	SSL SSA	Stainless Steel Linkage Stainless Steel Axles Only
BEARINGS:	BS BT	Stainless Steel Bearings Thrust Bearings
ROUND/OVAL TRANSITION:	CR CO	Transition Casing for Round Duct Transition Casing for Oval Duct
OPERATOR ACCESSORIES:	HLQ PCE PCI FMO FMI JK5 JK1 VCK	Hand Locking Quadrant External Chain Operator Internal Chain Operator Factory Mounted Actuator-Outside w/ side plate Factory Mounted Actuator-Internal w/ jackshaft 1/2" (13) Dia. Jackshifting for Single Section 1" (25) Dia. Jackshifting for Single Section Vertical Interconnection Kit

B
CONTROL DAMPERS

At Nailor Industries, we take pride in our flexibility to meet the needs of your specific applications. The options listed above provide a variety of commonly used modifications to satisfy the majority of today's diverse requirements. Should your application require a more unique configuration, please consult your authorized Nailor Representative or the Nailor Industries office nearest you for assistance.

HOW TO SPECIFY OR TO ORDER

MODELS: 2010/2020

HOW TO ORDER:

Standard construction is shown in highlighted box. Option codes are listed below. See previous page for description of options.

MODEL	SIZE (W X H)	FRAME MATERIAL		FRAME TYPE	FRAME GAUGE	DRIVE LOCATION	OPTIONAL BLADE LINKAGE	BEARINGS	ROUND/OVAL TRANSITION OPERATOR ACCESSORIES
2010 2020	ie: 48 x 24	GLV EAF SSF	HC FF FFB FR FRB FD FDB	16G 14G 13G 12G	DR/DL	- SSL SSA	BO BT BS	- CR CO	- HLQ FMO FMI PCE PCI JK5 JK1 VCK

- Notes:
1. Right hand driveshaft is standard. For left hand driveshaft simply rotate the damper so that the driveshaft is on left hand side, as blade and jamb seals are designed to work with airflow in either direction. 1/2" (13) or 1" (25) dia. jackshaftering is standard on all multiple section wide units.
 2. Frame Type Options FF, FR, FD, and Frame Gauge Options are only available on standard galvanized steel frame.
 3. If Pull Chain Operator option is selected, please specify length of chain required.
 4. If Option CR Round Transition casing (or CO) is selected please order by duct size diameter ie: 36"Ø.

SUGGESTED SPECIFICATION:

Provide and install, as shown on plans and/or schedules, ultra-low leakage dampers meeting or exceeding the following criteria: Frame shall be constructed of 16 ga. (1.6) galvanized steel hat channel with mitered corners and die-formed corner gussets for rigidity and structural strength equivalent to 13 ga. (2.4) channel type frames. Blades shall be of Type 6063-T5 extruded aluminum airfoil design on maximum 6" (152) centers with integral structural reinforcing tube running full length of each blade. Blade axles shall be 1/2" (13) dia plated steel, double thru-bolted to blade at each end to provide positive locking connection. Hex or square friction-fit, or press-fit axles are not acceptable. Bearings shall be Oilite® self-lubricating bronze type. Blade linkage shall be zero-maintenance, out of airstream and totally concealed within the frame. Jackshafts shall be supplied on all multiple section assemblies in order to evenly distribute torque. Blade seals shall be extruded silicone mechanically locked in extruded blade slots and shall be field replaceable. Adhesive or clip-on type blade seals are not acceptable. Jamb seals shall be compression type stainless steel.

Submitted performance data, including leakage and pressure drop, to be based on tests in accordance with AMCA Standard 500-D. Dampers must comply with the requirements of AMCA 511 Certified Ratings Program and be qualified to bear the AMCA Seal for Air Leakage and Air Performance. Damper widths from 12" to 60" (305 to 1524) shall meet leakage Class 1A criteria of maximum 3 cfm/sq. ft. (15.2 L/s/m²) at 1" w.g. (.25 kPa) and 8 cfm/sq. ft. (40.6 L/s/m²) at 4" w.g. (1 kPa). Standard of acceptance: Nailor Industries Model 2020 (opposed blade).

For CR Round Transition Option, add the following:

Damper shall be provided with a 20 ga. (1.0) galvanized steel casing for sizes up to 36" (914) dia, 18 ga. (1.31) for larger sizes, complete with round collar on both sides. Casing shall be welded and caulked against leakage. Standard of acceptance: Nailor Industries Model 2010CR (parallel blade) or Model 2020CR (opposed blade).

- EXTRUDED ALUMINUM AIRFOIL BLADE AND FRAME
- ULTRA-LOW LEAKAGE
- HIGH PERFORMANCE

MODELS:

2010EAF PARALLEL BLADE

2020EAF OPPOSED BLADE



Models 2010EAF/2020EAF are Nailor's extruded aluminum airfoil blade and frame premium damper, ideal for use in high velocity, medium pressure, commercial and industrial HVAC systems. They offer unsurpassed leakage and pressure drop characteristics for superior performance that meets the IEC Code maximum leakage for building envelope dampers criteria of 3 cfm/ft.² (15.2 L/s/m²). Model 2020EAF opposed blade, is AMCA licensed, and provides the ultimate in ultra-low leakage performance characteristics. Features include a heavy duty extruded aluminum hat channel frame, no-maintenance concealed linkage, and rugged extruded aluminum airfoil blades that combine superior rigidity and deflection resistance with low pressure drop. Unique design compression type seals are keyed and locked into blade extrusion, providing the ultimate in ultra-low leakage and high performance.

B

CONTROL DAMPERS

STANDARD CONSTRUCTION:

- FRAME:** 5" x 7/8" x 0.125" (127 x 22 x 3.2)
Type 6063-T5 extruded aluminum frame.
- BLADES:** Airfoil type 6063-T5 extruded aluminum on 5 1/2" (140) centers.
- LINKAGE:** Concealed side type totally enclosed within the frame and out of the air stream. Plated steel.
- BEARINGS:** 1/2" (13) dia. Oilite[®] self-lubricating bronze.
- AXLES:** 1/2" (13) dia. plated steel double bolted to blades.
- DRIVE SHAFT:** 6" (152) long x 1/2" (13) dia. rigid drive shaft; or optional lock-on shaft with outboard support bracket (standard in Canada), on all single section dampers. A 1/2" (13) or 1" (25) dia. factory installed jackshaft is standard on all multiple section dampers.
- BLADE SEALS:** Silicone. Mechanically locked in place.
- JAMB SEALS:** Cambered stainless steel.
- MINIMUM SIZE:** Single blade (parallel) 8" x 8" (203 x 203). Two blades (parallel or opposed) 8" x 12" (203 x 305).
- MAXIMUM SIZE:** Single section size is 60" x 72" (1524 x 1829). Multiple section - unlimited.

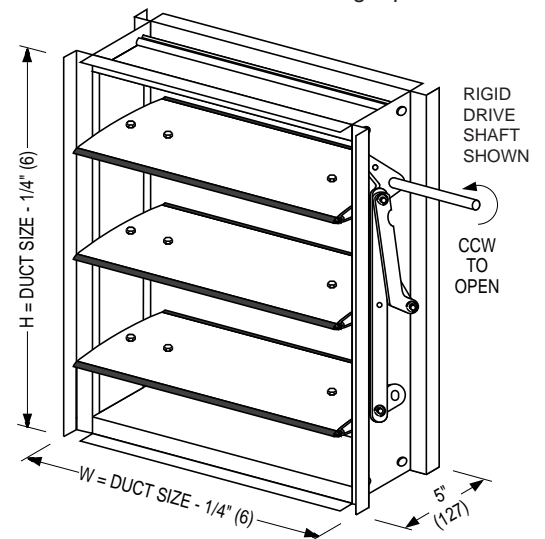

MODEL 2010EAF
PARALLEL BLADE

MODEL 2020EAF
OPPOSED BLADE

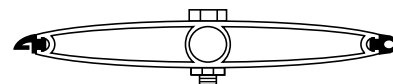
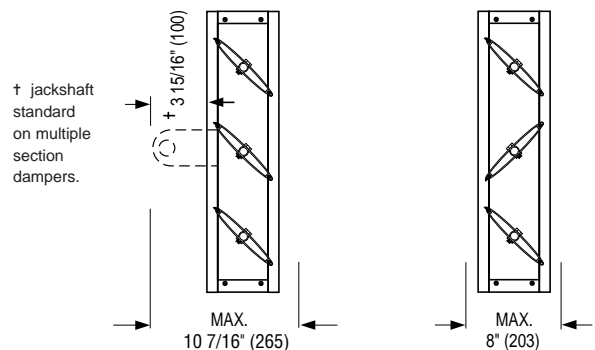

EXTRUDED ALUMINUM AIRFOIL BLADE

MODELS: 2010EAF/2020EAF PERFORMANCE DATA:

PERFORMANCE LIMITATIONS:

DAMPER WIDTH		MAXIMUM SYSTEM PRESSURE	MAXIMUM SYSTEM VELOCITY
IN.	MM		
60	1524	5.0" w.g.	3000 FPM
48	1219	8.0" w.g.	4000 FPM
36	914	10.0" w.g.	4500 FPM
24	610	12.0" w.g.	5000 FPM
12	305	14.0" w.g.	6000 FPM

The 2000 Series with its standard maximum single section and multiple section sizing limitation may be used in applications with system pressures of up to 5.0" w.g.. The 2000 Series may also be used in systems with higher total pressures by reducing the damper section width as shown in the table.

Temperature Range: -50°F to 250°F (-45°C to 157°C)



Nailor Industries Inc. certifies that the Model 2020EAF Damper shown herein is licensed to bear the AMCA seal. The ratings shown are based on tests and procedures performed in accordance with AMCA Publication 511 and comply with the requirements of the AMCA Certified Ratings Program. The AMCA Certified Ratings Seal applies to air leakage ratings and air performance ratings. Model 2010EAF is not licensed to bear the AMCA seal.

LEAKAGE CLASS:

DAMPER WIDTH	@ 1" w.g. (0.25 kPa)	@ 4" w.g. (1.0 kPa)	@ 8" w.g. (2.0 kPa)	@ 12" w.g. (3.0 kPa)
12" (305)	1A	1A	1A	1A
24" (610)	1A	1A	1A	1A
36" (914)	1A	1A	1A	—
48" (1219)	1A	1A	—	—
60" (1524)	1A	1A	—	—

Maximum leakage permitted for Class rating is as follows:

Class 1A: 3 cfm/sq. ft. @ 1" w.g. (15.2 l/s/m² @ 0.25 kPa)

8 cfm/sq. ft. @ 4" w.g. (40.6 l/s/m² @ 1.0 kPa)

11 cfm/sq. ft. @ 8" w.g. (55.9 l/s/m² @ 2.0 kPa)

14 cfm/sq. ft. @ 12" w.g. (71.1 l/s/m² @ 3.0 kPa)

Leakage tested in accordance with AMCA Standard 500-D-98. Data based on a torque of 8" lbs./sq. ft. (minimum 20" lbs.) applied to hold the damper in closed position. Leakage class is based on operation between 50°F and 104°F (10°C and 40°C). Data corrected to standard air density of 0.075 lbs./ft.³

PRESSURE DROP:

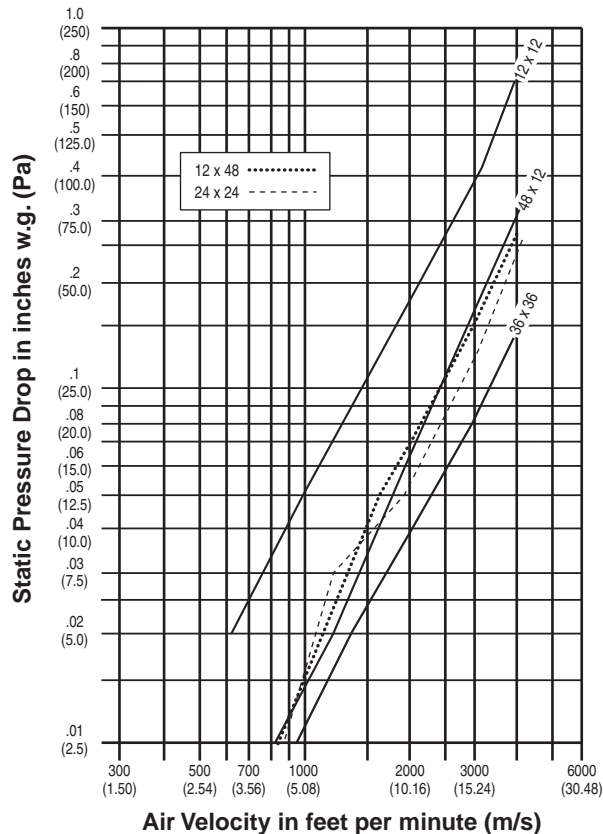

Pressure drop tested per AMCA Standard 500-D-98, Figure 5.3. Data corrected to standard air density of 0.075 lbs./ft.³.

Size: 12 x 12 (305 x 305)

VELOCITY fpm (m/s)	PRESSURE DROP in. w.g. (Pa)
492 (2.50)	.01 (2)
992 (5.04)	.04 (10)
2056 (10.44)	.17 (42)
2994 (15.21)	.35 (87)
3922 (19.93)	.61 (151)

Size: 24 x 24 (610 x 610)

VELOCITY fpm (m/s)	PRESSURE DROP in. w.g. (Pa)
891 (4.53)	.01 (2)
1244 (6.32)	.02 (5)
1942 (9.87)	.04 (10)
3074 (15.62)	.10 (25)
4344 (22.07)	.20 (50)

Size: 36 x 36 (914 x 914)

VELOCITY fpm (m/s)	PRESSURE DROP in. w.g. (Pa)
513 (2.61)	.01 (2)
1087 (5.52)	.01 (2)
1959 (9.95)	.03 (7)
2974 (15.11)	.06 (15)
3922 (19.93)	.12 (30)

Size: 48 x 12 (1219 x 305)

VELOCITY fpm (m/s)	PRESSURE DROP in. w.g. (Pa)
881 (4.48)	.01 (2)
1249 (6.35)	.02 (5)
1950 (9.91)	.04 (10)
3086 (15.68)	.13 (32)
4361 (22.15)	.26 (65)

Size: 12 x 48 (305 x 1219)

VELOCITY fpm (m/s)	PRESSURE DROP in. w.g. (Pa)
869 (4.42)	.01 (2)
1663 (8.45)	.05 (12)
2027 (10.30)	.07 (17)
2935 (14.91)	.15 (37)
4008 (20.36)	.27 (67)

MODELS: 2010EAF/2020EAF

AVAILABLE OPTIONS/ACCESSORIES:

The following construction options and accessories are available on Models 2010EAF /2020EAF. See page B55 for detailed description of options/accessories.

	CODE	DESCRIPTION
BLADE LINKAGE:	SSL SSA	Stainless Steel Linkage Stainless Steel Axles Only
BEARINGS:	BS BT	Stainless Steel Bearings Thrust Bearings
ROUND/OVAL TRANSITION:	CR CO	Transition Casing for Round Duct Transition Casing for Oval Duct
OPERATOR ACCESSORIES:	HLQ PCE PCI FMO FMI JK5 JK1 VCK	Hand Locking Quadrant External Chain Operator Internal Chain Operator Factory Mounted Actuator-Outside w/ side plate Factory Mounted Actuator-Internal w/ jackshaft 1/2" (13) Dia. Jackshafting for Single Section 1" (25) Dia. Jackshafting for Single Section Vertical Interconnection Kit

B

CONTROL DAMPERS

At Nailor Industries, we take pride in our flexibility to meet the needs of your specific applications. The options listed above provide a variety of commonly used modifications to satisfy the majority of today's diverse requirements. Should your application require a more unique configuration, please consult your authorized Nailor Representative or the Nailor Industries office nearest you for assistance.

HOW TO SPECIFY OR TO ORDER

MODELS: 2010EAF/2020EAF

HOW TO ORDER:

Standard construction is shown in highlighted box. Option codes are listed below. See previous page for description of options.

	MODEL	SIZE (W X H)	FRAME MATERIAL	DRIVE LOCATION	OPTIONAL BLADE LINKAGE	BEARINGS	ROUND/OVAL TRANSITION OPERATOR ACCESSORIES
2010	ie: 48 x 24	EAF	DR/DL	–	BO	–	–
2020		↑		SSL SSA	BS BT	CR CO	HLQ FMO FMI PCE PCI JK5 JK1 VCK

- Notes:
- ↑ Arrow indicates 'must select' option.
 - Right hand driveshaft is standard. For left hand driveshaft simply rotate the damper so that the driveshaft is on left hand side, as blade and jamb seals are designed to work with airflow in either direction. 1/2" (13) or 1" (25) dia. jackshafts is standard on all multiple section wide units.
 - If Pull Chain Operator option is selected, please specify length of chain required.
 - If Option CR Round Transition casing (or CO) is selected please order by duct size diameter ie: 36"ø.

SUGGESTED SPECIFICATION:

Provide and install, as shown on plans and/or schedules, ultra low-leakage dampers meeting or exceeding the following criteria: Frame shall be constructed of type 6063-T5 extruded aluminum hat channel design of minimum 0.125" (3.2) thickness. Blades shall be of type 6063-T5 extruded aluminum airfoil design on maximum 6" (152) centers with integral structural reinforcing tube running full length of each blade. Blade axles shall be 1/2" (13) dia. plated steel, double thru-bolted to blade at each end to provide positive locking connection. Hex or square friction-fit, or press-fit axles are not acceptable. Bearings shall be Oilite® self-lubricating bronze type. Blade linkage shall be zero-maintenance, out of airstream and totally concealed within the frame. Jackshafts shall be supplied on all multiple section assemblies in order to evenly distribute torque. Blade seals shall be extruded silicone mechanically locked in extruded blade slots and shall be field replaceable. Adhesive or clip-on type blade seals are not acceptable. Jamb seals shall be compression type stainless steel.

Submitted performance data, including leakage and pressure drop, to be based on tests in accordance with AMCA Standard 500-D. Dampers must comply with the requirements of AMCA 511 Certified Ratings Program and be qualified to bear the AMCA Seal for Air Leakage and Air Performance. Damper widths from 12" to 60" (305 to 1524) shall meet leakage Class 1A criteria of maximum 3 cfm/sq. ft. (15.2 L/s/m²) at 1" w.g. (.25 kPa) and 8 cfm/sq. ft. (40.6 L/s/m²) at 4" w.g. (1 kPa). Standard of acceptance: Nailor Industries Model 2020EAF.

For CR Round Transition Option, add the following:

Damper shall be provided with a 20 ga. (1.0) galvanized steel casing for sizes up to 36" (914) dia., 18 ga. (1.31) for larger sizes, complete with round collar on both sides. Casing shall be welded and caulked against leakage. Standard of acceptance: Nailor Industries Model 2010EAF (parallel blade) or Model 2020EAF (opposed blade).

- INSULATED DAMPER
- EXTRUDED ALUMINUM AIRFOIL BLADE
- ULTRA-LOW LEAKAGE
- HIGH PERFORMANCE

MODELS:

- 2010IB/IBF PARALLEL BLADE**
- 2020IB/IBF OPPOSED BLADE**



Model 2020IBF

The Series 2010IB/IBF and 2020IB/IBF are Nailor's premium insulated dampers featuring rugged extruded aluminum airfoil blades, suitable for use in high velocity, medium pressure commercial and industrial systems.

These ultra-low leakage dampers with insulated blade and frame, help limit thermal conductivity as well as air infiltration, making them ideal for use in more extreme applications. Features include a choice of heavy-duty frames, no-maintenance concealed linkage and unique design compression type seals that are keyed and locked into the blade extrusion, providing low pressure drop and high performance. Model 2020IBF is AMCA licensed for air leakage and air performance and meets the IEC Code maximum leakage for building envelope dampers criteria of 3 cfm/ft² (15.2 l/s/m²).

B
CONTROL DAMPERS

STANDARD CONSTRUCTION:

- FRAME:** 5" x 7/8" x 16 ga. (127 x 22 x 1.6) galvanized steel hat channel with die-formed corner gussets for reinforcement and extra strength.
- BLADES:** Airfoil type 6063-T5 extruded aluminum on 5 1/2" (140) centers.
- INSULATION:** Blades: Polyurethane foam; R value 2.19 (IB/IBF models).
Frame: Polystyrene foam; (Included with IBF model only).
- LINKAGE:** Concealed side type totally enclosed within the frame and out of the airstream. Plated steel.
- BEARINGS:** 1/2" (13) dia. Oilite® self-lubricating bronze.
- AXLES:** 1/2" (13) dia. plated steel double bolted to blades.
- DRIVE SHAFT:** 6" (152) long x 1/2" (13) dia. rigid driveshaft; or optional lock-on shaft with outboard support bracket (standard in Canada), on all single section dampers. A 1/2" (13) or 1" (25) dia. factory installed jackshaft is standard on all multiple section dampers.
- BLADE SEALS:** Silicone. Mechanically locked into place.
- JAMB SEALS:** Cambered stainless steel.
- MINIMUM SIZE:** Single blade (parallel) 8" x 8" (203 x 203). Two blades (parallel or opposed) 8" x 12" (203 x 305).
- MAXIMUM SIZE:** Single section size is 60" x 72" (1524 x 1829). Multiple section - unlimited.

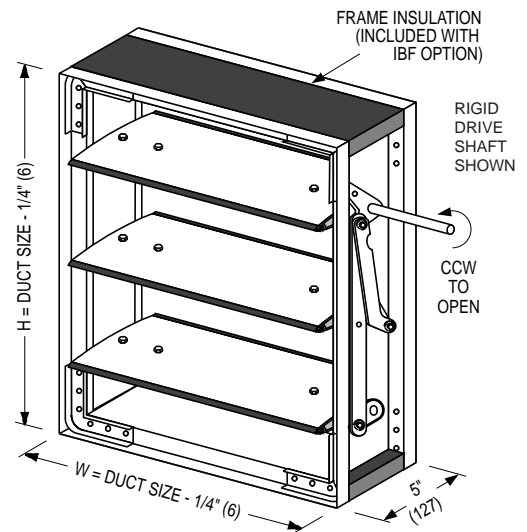

NOTE: IB MODEL: INSULATED BLADE ONLY
IBF MODEL: INSULATED BLADE AND FRAME

MODELS 2010IB/IBF
PARALLEL BLADE

MODELS 2020IB/IBF
OPPOSED BLADE

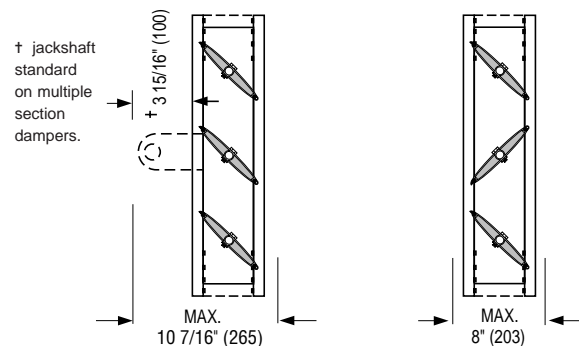

A WORD ABOUT INSULATED DAMPERS...



Air infiltration between the damper blades and frame is the most significant factor attributed to frost build-up on and around outside air dampers which can lead to damper/actuator damage and potential for further system damage such as coil freeze-ups etc. With an ultra-low mean leakage rate of 0.18 CFM/sq. ft. (0.91 l/s per sq. meter) at 1" w.g. static pressure combined with insulated blades and frame, the Nailor 2000IBF Series provides the protection required for many applications in harsher climates....

NAILOR COMBINES THE LOWEST LEAKAGE MULTI-BLADE DAMPER, THAT IS AMCA LICENSED, WITH THE LOW HEAT CONDUCTIVITY DESIGN OF INSULATED BLADE AND FRAME. This combination provides excellent protection for colder ambient conditions!

PERFORMANCE LIMITATIONS:

DAMPER WIDTH		MAXIMUM SYSTEM PRESSURE	MAXIMUM SYSTEM VELOCITY
IN.	MM		
60	1524	5.0" w.g.	3000 FPM
48	1219	8.0" w.g.	4000 FPM
36	914	10.0" w.g.	4500 FPM
24	610	12.0" w.g.	5000 FPM
12	305	14.0" w.g.	6000 FPM

The 2000 Series with its standard maximum single section and multiple section sizing limitation may be used in applications with system pressures of up to 5.0" w.g.. The 2000 Series may also be used in systems with higher total pressures by reducing the damper section width as shown in the table.

PRESSURE DROP:

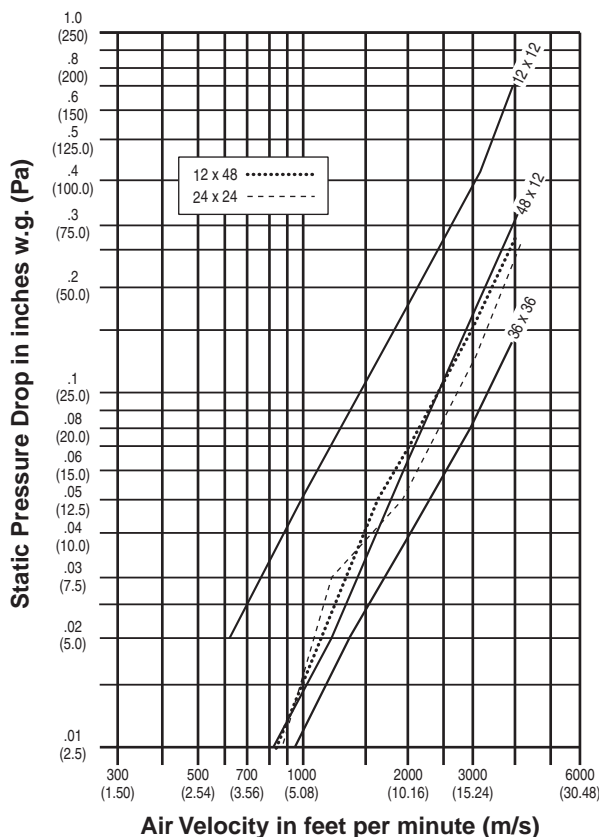

Pressure drop tested per AMCA Standard 500-D-98, Figure 5.3. Data corrected to standard air density of 0.075 lbs./ft.³.

LEAKAGE CLASS:

DAMPER WIDTH	@ 1" w.g. (0.25 kPa)	@ 4" w.g. (1.0 kPa)	@ 8" w.g. (2.0 kPa)	@ 12" w.g. (3.0 kPa)
12" (305)	1A	1A	1A	1A
24" (610)	1A	1A	1A	1A
36" (914)	1A	1A	1A	—
48" (1219)	1A	1A	—	—
60" (1524)	1A	1A	—	—

Maximum leakage permitted for Class rating is as follows:

- Class 1A: 3 cfm/sq. ft. @ 1" w.g. (15.2 l/s/m² @ 0.25 kPa)
- 8 cfm/sq. ft. @ 4" w.g. (40.6 l/s/m² @ 1.0 kPa)
- 11 cfm/sq. ft. @ 8" w.g. (55.9 l/s/m² @ 2.0 kPa)
- 14 cfm/sq. ft. @ 12" w.g. (71.1 l/s/m² @ 3.0 kPa)

Leakage tested in accordance with AMCA Standard 500-D-98. Data based on a torque of 8" lbs./sq. ft. (minimum 20" lbs.) applied to hold the damper in closed position. Leakage class is based on operation between 50°F and 104°F (10°C and 40°C). Data corrected to standard air density of 0.075 lbs./ft.³

Temperature Range: -50°F to 250°F (-45°C to 157°C)



Nailor Industries Inc. certifies that the Model 2020IBF Damper shown herein is licensed to bear the AMCA seal. The ratings shown are based on tests and procedures performed in accordance with AMCA Publication 511 and comply with the requirements of the AMCA Certified Ratings Program. The AMCA Certified Ratings Seal applies to air leakage ratings and air performance ratings. Model 2010IBF is not licensed to bear the AMCA seal.

**MODELS: 2010IB/IBF
2020IB/IBF**

AVAILABLE OPTIONS/ACCESSORIES:

The following construction options and accessories are available on Models 2010IB/IBF and 2020IB/IBF. See page B55 for detailed description of options/accessories.

	CODE	DESCRIPTION
FRAME MATERIAL:	EAF SSF	Extruded Aluminum Frame Note: For Extruded Aluminum Frame details, see Models 2010EAF/2020EAF Stainless Steel Frame
FRAME TYPE:	FF FR FD	Front Flange Rear Flange Double Flange Note: Flange Options are not available on EAF or SSF frame styles.
FRAME GAUGE:	14G 13G 12G	14 Gauge 13 Gauge 12 Gauge Note: Frame Gauge Option applies to standard galvanized steel frame only.
INSULATION:	IB IBF	Insulated Blades Only Insulated Blades and Frame
BLADE LINKAGE:	SSL SSA	Stainless Steel Linkage Stainless Steel Axes Only
BEARINGS:	BS BT	Stainless Steel Bearings Thrust Bearings
ROUND/OVAL TRANSITION:	CR CO	Transition Casing for Round Duct Transition Casing for Oval Duct
OPERATOR ACCESSORIES:	HLQ PCE PCI FMO FMI JK5 JK1 VCK	Hand Locking Quadrant External Chain Operator Internal Chain Operator Factory Mounted Actuator-Outside w/ side plate Factory Mounted Actuator-Internal w/ jackshaft 1/2" (13) Dia. Jackshafting for Single Section 1" (25) Dia. Jackshafting for Single Section Vertical Interconnection Kit

B

CONTROL DAMPERS

At Nailor Industries, we take pride in our flexibility to meet the needs of your specific applications. The options listed above provide a variety of commonly used modifications to satisfy the majority of today's diverse requirements. Should your application require a more unique configuration, please consult your authorized Nailor Representative or the Nailor Industries office nearest you for assistance.

HOW TO SPECIFY OR TO ORDER

MODELS: 2010IB/IBF and 2020IB/IBF

HOW TO ORDER:

Standard construction is shown in highlighted box. Option codes are listed below. See previous page for description of options.

MODEL	SIZE (W X H)	FRAME MATERIAL	FRAME TYPE	FRAME GAUGE	INSULATION	DRIVE LOCATION	OPTIONAL BLADE LINKAGE	BEARINGS	ROUND/OVAL TRANSITION OPERATOR ACCESSORIES
2010	ie: 48 x 24	GLV	HC	16G	IB or IBF	DR/DL	-	BO	-
2020		EAF	FF	14G	↑		SSL	BT	CR
		SSF	FR	13G			SSA	BS	CO
			FD	12G					HLQ
									FMO
									FMI
									PCE
									PCI
									JK5
									JK1
									VCK

- Notes:
- ↑ Arrow indicates 'must select' option.
 - Right hand driveshaft is standard. For left hand driveshaft simply rotate the damper so that the driveshaft is on left hand side, as blade and jamb seals are designed to work with airflow in either direction. 1/2" (13) or 1" (25) dia. jackshafting is standard on all multiple section wide units.
 - If Pull Chain Operator option is selected, please specify length of chain required.
 - Frame Type Options FF, FR, FD, and Frame Gauge Options are only available on standard galvanized steel frame.
 - If Option CR Round Transition casing (or CO) is selected please order by duct size diameter ie: 36"Ø.

SUGGESTED SPECIFICATION:

Provide and install, as shown on plans and/or schedules, ultra low-leakage insulated dampers meeting or exceeding the following criteria: Frame shall be constructed of 16 ga. (1.6) galvanized steel hat channel with mitered corners and die-formed corner gussets for rigidity and structural strength equivalent to 13 ga. (2.4) channel type frames. Frame shall be insulated with polystyrene type foam having an R value of 5.0, on minimum of three sides. (Specifier to delete this sentence if IB option, insulated blades only, is required.) Blades shall be of Type 6063-T5 extruded aluminum airfoil design on maximum 6" (152) centers with integral structural reinforcing tube running full length of each blade. Blades shall be internally insulated with polyurethane type foam having an R value of 2.19. Blade axles shall be 1/2" (13) dia. plated steel, double thru-bolted to blade at each end to provide positive locking connection. Hex or square friction-fit, or press-fit axles are not acceptable. Bearings shall be Oilite® self-lubricating bronze type. Blade linkage shall be zero-maintenance, out of airstream and totally concealed within the frame. Jackshafts shall be supplied on all multiple section assemblies in order to evenly distribute torque. Blade seals shall be extruded silicone mechanically locked in extruded blade slots. Adhesive or clip-on type blade seals are not acceptable. Jamb seals shall be compression type stainless steel. All seals shall be field replaceable.

Submitted performance data, including leakage and pressure drop, to be based on tests in accordance with AMCA Standard 500-D. Dampers must comply with the requirements of AMCA 511 Certified Ratings Program and be qualified to bear the AMCA Seal for Air Leakage and Air Performance. Damper widths from 12" to 60" (305 to 1524) shall meet leakage Class 1A criteria of maximum 3 cfm/sq. ft. (15.2 l/s/m²) at 1" w.g. (.25 kPa) and 8 cfm/sq. ft. (40.6 l/s/m²) at 4" w.g. (1 kPa). Standard of acceptance: Nailor Industries Model 2020IBF (opposed blade).

Specifier Notes: For Extruded Aluminum Frame (Option EAF) replace frame construction specification above with the following: Frame shall be constructed of Type 6063-T5 extruded aluminum hat channel design of minimum 0.125" (3.2) thickness.

For CR Round Transition Option, add the following:

Damper shall be provided with a 20 ga. (1.0) galvanized steel casing for sizes up to 36" (914) dia., 18 ga. (1.31) for larger sizes, complete with round collar on both sides. Casing shall be welded and caulked against leakage. Standard of acceptance: Nailor Industries Model 2010IBFCR (parallel blade) or Model 2020IBFCR (opposed blade).

- FOR MANUAL BALANCING
- STANDARD PERFORMANCE
- GALVANIZED STEEL

MODELS:

- 1810 PARALLEL BLADE
- 1820 OPPOSED BLADE

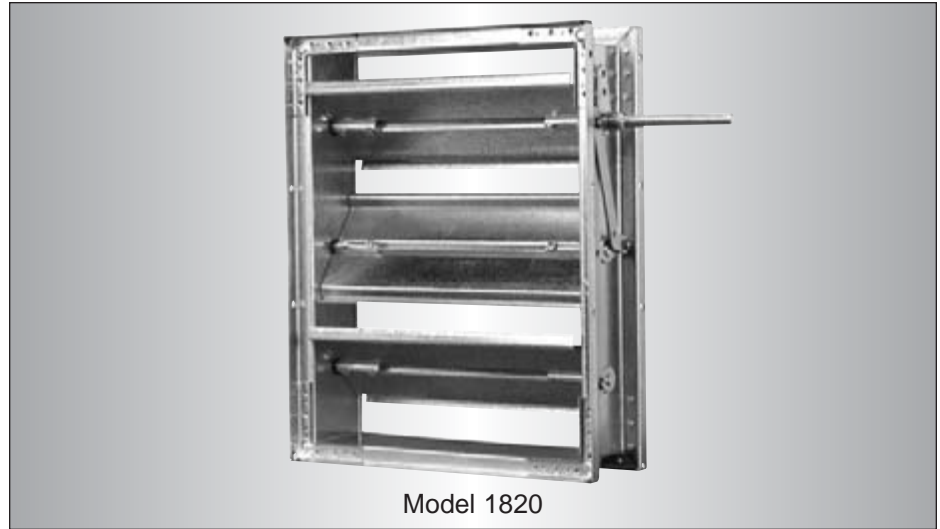

Model 1820

The Nailor 1810/1820 Series dampers are specially designed for manual balancing applications. They are suitable for use in the majority of commercial low to medium pressure and velocity HVAC systems. They are designed and built to provide a cost effective and reliable damper for reduced volume control and not positive shut-off. They are not recommended for applications as an automatic control damper.

The 1810/1820 Series includes many of the design features incorporated in the Nailor 1000 Series Control Dampers. These include a sturdy hat channel frame with die-formed corner gussets for reinforcement, a vee-blade design that maximizes strength and zero maintenance concealed linkage (out of the air stream) for reduced air turbulence.

Nailor's 1810/1820 Series exceed the volume damper design recommendations in SMACNA "HVAC Duct Construction Standards - Metal and Flexible" (2nd Edition, 1995), and offer an economical manufactured product alternative to custom 'shop built' dampers.

B CONTROL DAMPERS

STANDARD CONSTRUCTION:

- FRAME:** 5" x 7/8" x 16 ga. (127 x 22 x 1.6) galvanized steel hat channel with die-formed corner gussets. Low profile (flat top and bottom) on dampers 10" (254) high and under.
- BLADES:** 6" (152) wide on 5 1/2" (140) centers. 16 ga. (1.6) galvanized steel vee blade design. Parallel or opposed action.
- LINKAGE:** Concealed type totally enclosed within the frame and out of the air stream. Plated steel.
- BEARINGS:** 1/2" (13) Dia. Celcon®.
- AXLES:** 1/2" (13) Dia. plated steel double bolted to blades.
- DRIVE SHAFT:** 6" (152) long x 1/2" (13) dia. double bolted fixed driveshaft that can be easily removed; or optional 6" (152) long x 1/2" (13) dia. lock-on drive shaft (standard in Canada). Drive shaft on each damper section.
- MINIMUM SIZE:** Single blade (parallel): 6" x 4" (152 x 102). Two blades (parallel or opposed): 6" x 10" (152 x 254).
- MAXIMUM SIZE:** Single section size is 48" x 72" (1219 x 1829). Multiple section assembly: 96" x 144" (2438 x 3658).

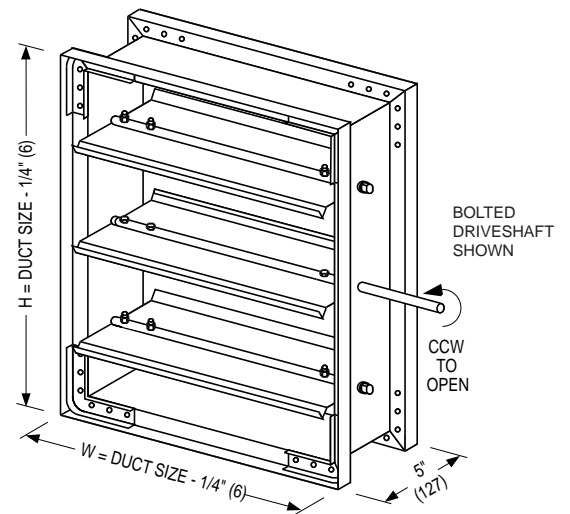

MODEL 1810
PARALLEL BLADE

MODEL 1820
OPPOSED BLADE

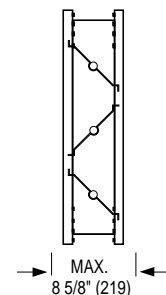
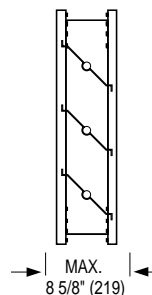

MODELS: 1810/1820

PERFORMANCE DATA:

Maximum System Pressure: 2.5" wg. (625 Pa)

Maximum Face Velocity: 2000 fpm (10 m/s)

Temperature Range: -50°F to 180°F (-45°C to 82°C)

PRESSURE DROP (damper fully open)

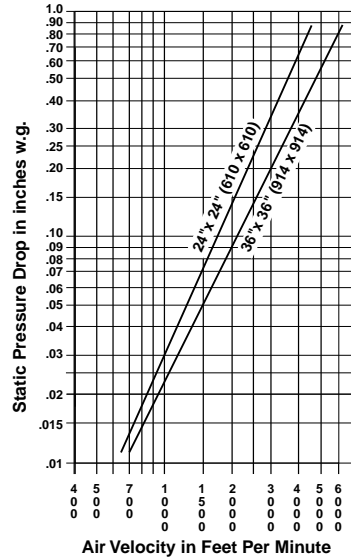

Imperial figures shown.
To convert to SI
(metric) system:

Multiply:
inches w.g. x .2486
= kilopascals
fpm x .00508 = meters
per second

Tested per AMCA standard 500-D, Fig. 5.3.

AVAILABLE OPTIONS/ACCESSORIES:

The following construction options and accessories are available on Models 1810/1820. See page B55 for detailed description of options/accessories.

	CODE	DESCRIPTION
MATERIAL:	304	Stainless Steel Construction
BEARINGS:	BO BS	Oilite® Bronze Bearings Stainless Steel Bearings
ROUND/OVAL TRANSITION:	CR CO	Transition Casing for Round Duct Transition Casing for Oval Duct
OPERATOR ACCESSORIES:	HLQ HL2	Hand Locking Quadrant Hand Locking Quadrant w/2" Stand-off Bracket

At Nailor Industries, we take pride in our flexibility to meet the needs of your specific applications. The options listed above provide a variety of commonly used modifications to satisfy the majority of today's diverse requirements. Should your application require a more unique configuration, please consult your authorized Nailor Representative or the Nailor Industries office nearest you for assistance.

HOW TO SPECIFY OR TO ORDER

MODELS: 1810/1820

HOW TO ORDER:

Standard construction is shown in highlighted box. Option codes are listed below. See previous page for description of options.

MODEL	SIZE (W X H)	MATERIAL	DRIVE LOCATION	BEARINGS	ROUND/OVAL TRANSITION	OPERATOR ACCESSORIES
1810	ie: 48 x 24	GLV	DR/DL	BC	-	-
1820		304		BO BS	CR CO	HLQ HL2

- Notes:
1. Frame Type Options are only available on standard galvanized steel frame.
 2. Right hand driveshaft is standard. For left hand driveshaft simply rotate the damper so that driveshaft is on left hand side. Two section wide units will have driveshaft on both sides.
 3. If Option CR Round Transition casing (or CO) is selected please order by duct size diameter ie: 36"Ø.

SUGGESTED SPECIFICATION:

Provide and install, as shown on plans and/or schedules, manual balancing dampers meeting or exceeding the following criteria: Frame shall be constructed of 16 ga. (1.6) galvanized steel hat channel with mitered corners and die-formed corner gussets for rigidity and structural strength equivalent to 13 ga. (2.4) channel type frames. Blades shall be of triple-vee design, 16 ga. (1.6) galvanized steel, on maximum 6" (152) centers, in parallel or opposed (please select) configuration. Blade axles shall be 1/2" (13) dia. plated steel, double thru-bolted to blade at each end. Hex or square friction-fit, or press-fit axles are not acceptable. Bearings shall be Celcon® molded synthetic type. Blade linkage shall be zero-maintenance, out of airstream and totally concealed within the frame. Provide each damper section with a hand locking quadrant for positive setting of blades at any position. Standard of acceptance: Nailor Industries Model 1810 (parallel blade) or Model 1820 (opposed blade).

For CR Round Transitional Option, add the following:

Damper shall be provided with a 20 ga. (1.0) galvanized steel casing for sizes up to 36" (914) dia., 18 ga. (1.31) for larger sizes, complete with round collar on both sides. Casing shall be welded and caulked against leakage. Standard of acceptance: Nailor Industries Model 1810CR (parallel blade) or Model 1820CR (opposed blade).

- FOR MANUAL BALANCING
- SINGLE BLADE
- GALVANIZED STEEL

MODEL: 1870

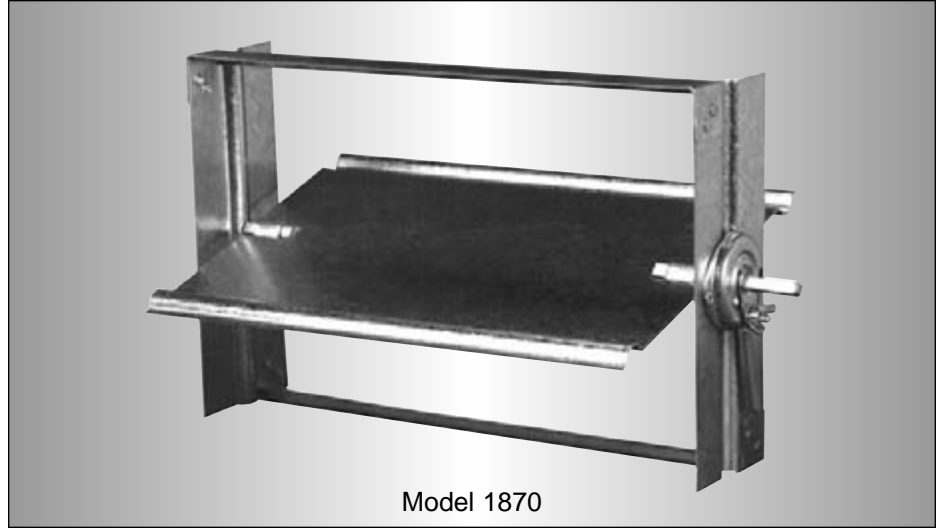

Model 1870

B

The Model 1870 Manual Balancing Damper is an economical branch duct balancing damper designed for use in most metal and fibre ductboard HVAC systems. The low profile frame and sills provide maximum free area. The ribbed forms in the blade and frame are for extra strength. A locking manual hand quadrant is provided with each damper.

CONTROL DAMPERS

STANDARD CONSTRUCTION:

- FRAME:** 3" wide x 18 ga. (102 x 1.3) galvanized steel.
- BLADES:** 20 ga. (1.0) galvanized steel up to 24" x 12" (610 x 305).
18 ga. (1.3) galvanized steel above 24" x 12" (610 x 305).
- SHAFT:** 1/4" (6) square plated steel.
- QUADRANT:** Plated steel with locking operator (shipped loose).
- MINIMUM SIZE:** 4" x 4" (102 x 102).
All units are manufactured 1/4" (6) under nominal size.
- MAXIMUM SIZE:** 36" x 12" (914 x 305).
All units are manufactured 1/4" (6) under nominal size.

For larger sizes refer to Models 1810 and 1820.

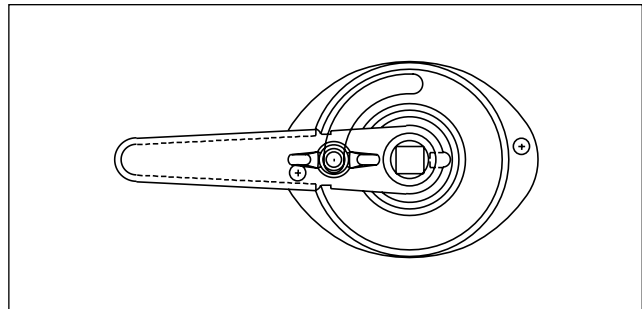
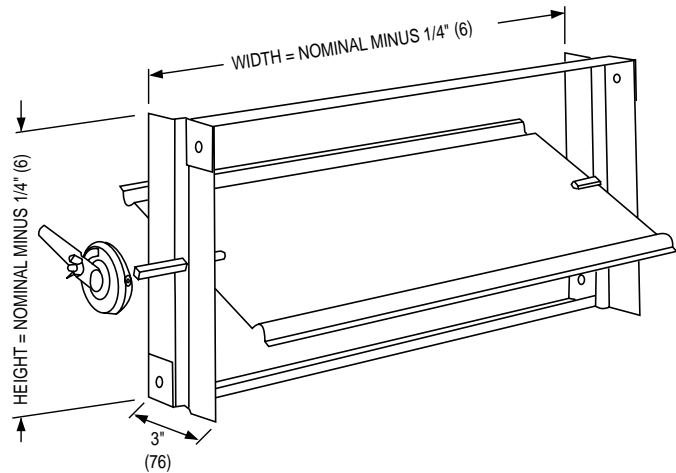

LOCKING QUADRANT

MODEL: 1870

PERFORMANCE DATA:

Maximum System Pressure: 2" w.g. (0.49 kPa)

Maximum Face Velocity: 1500 fpm (7.6 m/s)

Temperature Range: -50°F to 180°F (-45°C to 82°C)

Dampers are designed to operate in a clean, dry environment.

AVAILABLE OPTIONS/ACCESSORIES:

The following construction options and accessories are available on Model 1870. See page B55 for detailed description of options/accessories.

	CODE	DESCRIPTION
MANUAL QUADRANT MOUNTING BRACKET:	SB	2" (51) Stand-off Bracket for Hand Quadrant (for externally insulated duct)

B

CONTROL DAMPERS

HOW TO ORDER OR TO SPECIFY

MODEL: 1870

HOW TO ORDER:

Standard construction is shown in highlighted box. Option codes are listed below. See above for description of options.

MODEL	SIZE (W X H)	OPERATOR ACCESSORIES
1870	ie: 24 x 12	HLQ SB

SUGGESTED SPECIFICATION:

Provide and install, as shown on plans and/or schedules, single blade manual balancing dampers meeting or exceeding the following criteria: Frame shall be constructed of 18 ga. (1.3) galvanized steel with structural ribs for maximum strength and low profile for maximum free area. Blades shall be constructed of 20 ga. (1.0) galvanized steel up to 24" x 12" (610 x 305); 18 ga. (1.3) galvanized steel above 24" x 12" (610 x 305), with structural ribs for extra strength. Blade shafts to be 1/4" (6) square plated steel, complete with a hand locking quadrant for positive setting of blade at any position. Standard of acceptance: Nailor Industries Model 1870.

- MANUAL BALANCING DAMPER
- FOR ROUND DUCT
- GALVANIZED STEEL

MODEL: 1890

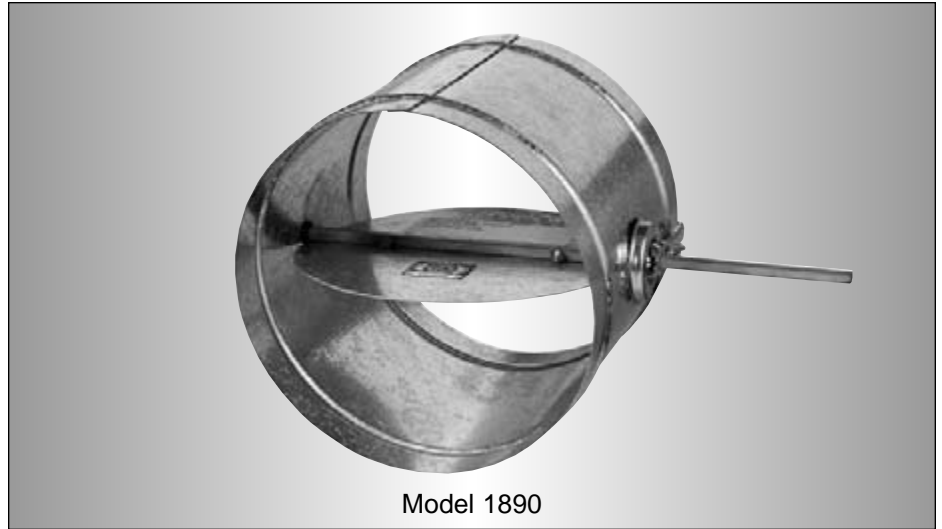

Model 1890

B

CONTROL DAMPERS

The Nailor Model 1890 is a manual balancing butterfly damper designed for all types of round ductwork applications and is suitable for use in most low pressure and velocity commercial HVAC systems. They are not intended for use as a positive shut-off or automatic control damper. The design features a sturdy beaded casing ideal for round spiral ductwork connections, and a corrosion resistant steel blade that can be locked in any position with the hand quadrant that is supplied as standard with the damper.

STANDARD CONSTRUCTION:

- FRAME:** 22 ga. (0.86) corrosion-resistant steel with stiffening beads up to 12" (305) dia. 20 ga. (0.91) over 12" (305) dia.
- BLADE:** 22 ga. (0.86) corrosion-resistant steel up to 12" (305) dia.. 20 ga. (1.0) over 12" (305) dia..
- DRIVE SHAFT/ AXLE:** 1/4" (6) square plated steel.
- QUADRANT:** Plated steel with locking operator (factory installed).
- AVAILABLE SIZES:** 4" (102) through 20" (508) diameter in nominal 1" (25) increments.

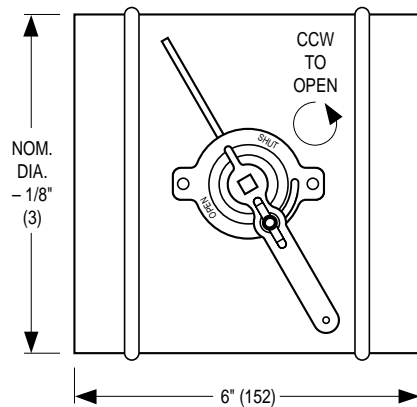
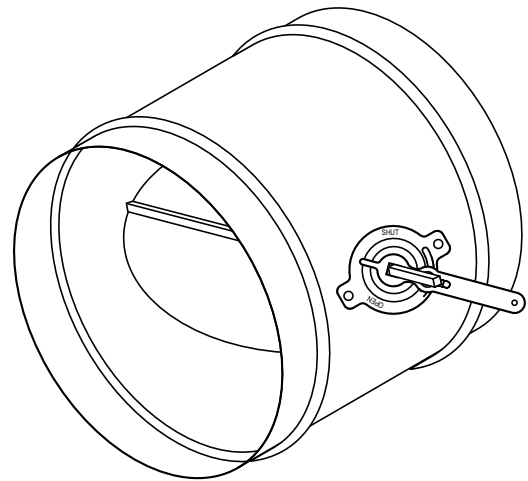

MODEL: 1890

PERFORMANCE DATA:

Maximum System Pressure: 2" w.g. (0.49 kPa)

Maximum Face Velocity: 2000 fpm (10 m/s)

Temperature Range: -50°F to 250°F (-45°C to 121°C)

Dampers are designed to operate in a clean, dry environment.

AVAILABLE OPTIONS/ACCESSORIES:

The following construction options and accessories are available on Model 1890. See page B55 for detailed description of options/accessories.

	CODE	DESCRIPTION
MANUAL QUADRANT MOUNTING BRACKET:	SB	2" (51) Stand-off Bracket for Hand Quadrant (for externally insulated duct)

B CONTROL DAMPERS

HOW TO ORDER OR TO SPECIFY

MODEL: 1890

HOW TO ORDER:

Standard construction is shown in highlighted box. Option codes are listed below. See above for description of options.

MODEL	SIZE (W X H)	OPERATOR ACCESSORIES
1890	ie: 12"Ø	HLQ SB

SUGGESTED SPECIFICATION:

Provide and install, as shown on plans and/or schedules, round balancing dampers meeting or exceeding the following criteria: Frame shall be constructed of 22 ga. (0.86) corrosion resistant steel with roll-formed stiffening beads up to 12" (305) dia.; 20ga. (0.91) over 12" (305) dia.. Blades shall be constructed of 22 ga. (0.86) corrosion resistant steel up to 12" (305) dia.; 20 ga. (1.0) over 12" (305) dia.. Blade shaft shall be 1/4" (6) square plated steel, complete with a hand locking quadrant for positive setting of blade at any position. Standard of acceptance: Nailor Industries Model 1890.

Notes:

B

CONTROL DAMPERS

Options and Accessories

Nailor control dampers are available with a variety of options and accessories to suit specific applications. To check if an option or accessory is available on a specific damper model, consult the AVAILABLE OPTIONS/ACCESSORIES page of that particular model.

MATERIAL OPTIONS:

OPTION CODE 304
STAINLESS STEEL CONSTRUCTION

All parts of damper (except blade seals) will be constructed of 304 stainless steel. Provides higher corrosion resistance against harsh atmospheric and process elements. Consult Nailor for specific application suitability.

OPTION CODE ALS
ALUMINUM CONSTRUCTION WITH
STAINLESS STEEL HARDWARE

Damper will be constructed with aluminum frame and blades with stainless steel linkage, bearings, axles and related hardware. Suitable for use in high humidity applications such as swimming pool areas etc.

OPTION CODE EAF
EXTRUDED ALUMINUM FRAME

Rugged Type 6063-T5 extruded aluminum frame for premium performance. See Models 2010EAF/2020EAF for further details.

OPTION CODE SSF
STAINLESS STEEL FRAME

Damper frame will be constructed from 304 stainless steel, fully welded with corner reinforcing brackets. Provides an extra rigid frame that is more corrosion resistant than galvanized steel.

BEARING OPTIONS:

OPTION CODE BO
OILITE® BRONZE BEARINGS



Bronze sintered (oil impregnated) self-lubricating oilite bearings provide long time lubrication making them ideal for use in applications where proper maintenance is uncertain or difficult.

OPTION CODE BS
STAINLESS STEEL BEARINGS



304 grade stainless steel bearings provide corrosion resistance in a wide variety of corrosive media. In higher heat applications, provides good oxidation resistance.

OPTION CODE BT
THRUST BEARINGS

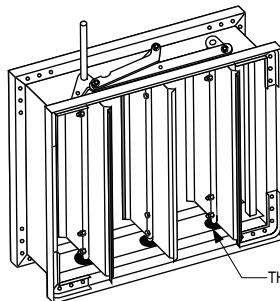

For use when damper is mounted with blades running vertically. Installed against lower blade edge to reduce friction due to weight of blades. When ordering, specify which side of damper will be bottom.

THRUST BEARING (TYPICAL)

Options and Accessories

Nailor control dampers are available with a variety of options and accessories to suit specific applications. To check if an option or accessory is available on a specific damper model, consult the AVAILABLE OPTIONS/ACCESSORIES page of that particular model.

FLANGED FRAME OPTIONS:

Available as an option on Series 1000, 1100, 1800 and 2000 steel hat channel frame control dampers, the 1 1/2" (38) flanged frames allow for direct fastening to wall or unit housings as well as flanged ductwork. Damper I.D. can be sized to match ductwork I.D. providing smooth transition that produces lower pressure drop and less turbulence across damper. Flange frames are also available with optional 9/32" (7) dia. bolt holes on 6" (152) centers for fast, convenient installation.

B

CONTROL DAMPERS

OPTION CODES

- FF** FLANGED FRONT
- FFB** FLANGED FRONT WITH BOLT HOLES

OPTION CODES

- FR** FLANGED REAR
- FRB** FLANGED REAR WITH BOLT HOLES

OPTION CODES

- FD** DOUBLE FLANGE
- FDB** DOUBLE FLANGE WITH BOLT HOLES

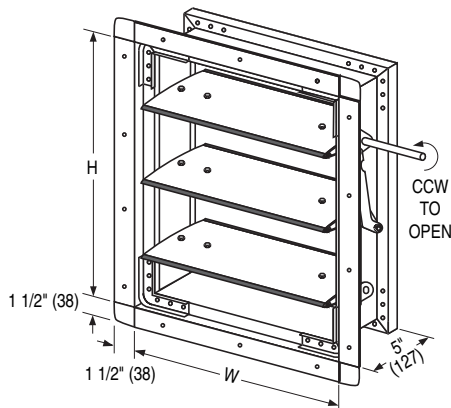
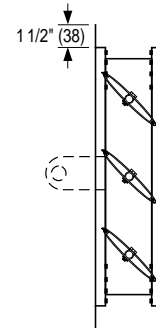
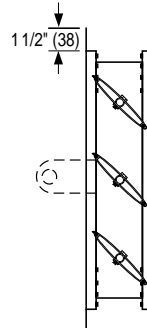
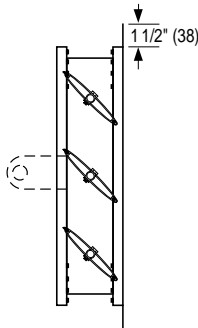

SINGLE SECTION DAMPER SHOWN WITH **FRB** OPTION: FLANGED REAR FRAME WITH 9/32" (7) DIA. BOLT HOLES ON 6" (152) CENTERS.

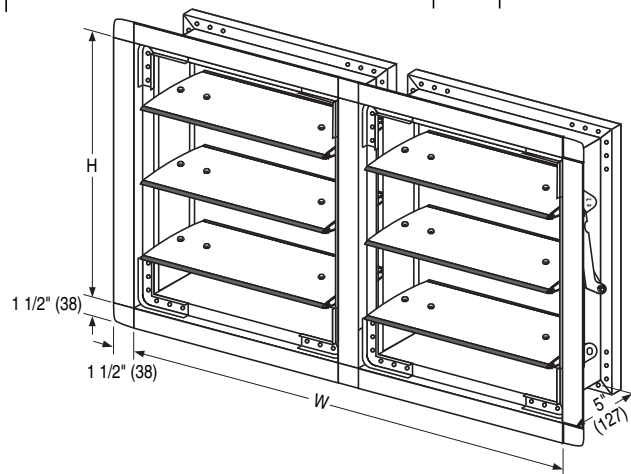

MULTIPLE SECTION DAMPER SHOWN WITH **FR** OPTION: FLANGED REAR FRAME (JACKSHAFT NOT SHOWN)

Options and Accessories

Nailor control dampers are available with a variety of options and accessories to suit specific applications. To check if an option or accessory is available on a specific damper model, consult the AVAILABLE OPTIONS/ACCESSORIES page of that particular model.

JAMB SEAL OPTIONS:

OPTION CODE JSM
METALLIC JAMB SEALS



Standard compression type metallic jamb seal used for reducing air leakage between blade ends and frame. Standard jamb seals on Models 1010/1020.

OPTION CODE JSS
STAINLESS STEEL JAMB SEALS



Compression type cambered stainless steel jamb seal for reducing air leakage between blade ends and frame. Provides higher resistance to corrosion and heat than our standard metallic jamb seal. Standard on Model Series' 1100 and 2000 dampers.

ROUND/OVAL TRANSITIONS:

OPTION CODE CR
TRANSITION ENCLOSURE FOR ROUND DUCT.

OPTION CODE CO
TRANSITION ENCLOSURE FOR OVAL DUCT

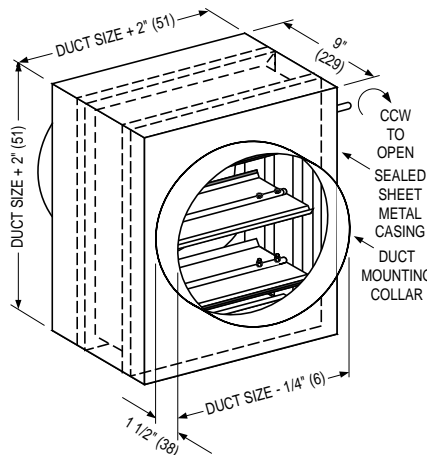

TYPE CR (FOR ROUND DUCT) SHOWN

The CR transition enclosure option allows for connection of multi-blade control dampers to round ductwork. The CO transition enclosure option allows for connection of multi-blade control dampers to oval ductwork. Casing and collars are constructed from 20 ga. (1.0) galvanized steel (18 ga. (1.31) on sizes 36" x 36" (914 x 914) and up) and are tack welded and caulked against leakage.

MAXIMUM SIZE:

Single section:
46" (1168) diameter.
For larger sizes contact factory.

Options and Accessories

Nailor control dampers are available with a variety of options and accessories to suit specific applications. To check if an option or accessory is available on a specific damper model, consult the AVAILABLE OPTIONS/ACCESSORIES page of that particular model.

LINKAGE MATERIAL OPTIONS:

OPTION CODE **SSL**
STAINLESS STEEL LINKAGE

All linkage, axles and bearings will be of 304 Stainless Steel. Provides better resistance to corrosion and good resistance to oxidation in higher heat applications.

OPTION CODE **SSA**
STAINLESS STEEL AXLES ONLY

Blade axles only will be of 304 Stainless Steel. Provides better resistance to corrosion and good resistance to oxidation in higher heat applications.

DRIVE SHAFT OPTION:

OPTION CODE **DLO**
LOCK-ON DRIVE SHAFT

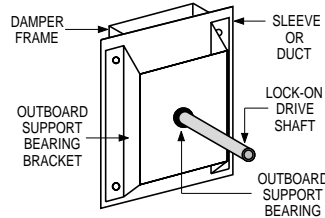

Shipped loose and can be installed before or after damper is mounted in duct. Unique spring clip locks shaft onto damper drive for firm connection. Each lock-on drive shaft is shipped complete with an outboard support bracket with bearing that can be fastened to outside of duct for extra support. Lock-on drive shafts are standard on dampers manufactured in Canada.

Note: **OPTION CODE DSR rigid drive shaft** (welded) is provided as standard on most control damper models. In Canada, **DSR** is available as an option.

BLADE SEAL OPTION:

OPTION CODE **BSP**
POLYURETHANE FOAM BLADE SEAL

FOR MODELS 1012/1022

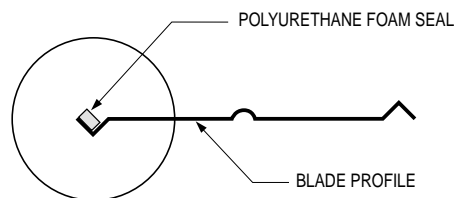

Available on Models 1012/1022 as an economical alternative to extruded seals, the polyurethane foam seal adheres to blade edge with self-adhesive backing. Suitable for light duty use in applications involving low static pressures and velocities.

Options and Accessories

Nailor control dampers are available with a variety of options and accessories to suit specific applications. To check if an option or accessory is available on a specific damper model, consult the AVAILABLE OPTIONS/ACCESSORIES page of that particular model.

BLADE LINKAGE OPTION:

OPTION CODE LF
FACE LINKAGE

Nailor's beefy plated steel linkage, uniquely installed directly to face of blades with integral heavy-duty brackets. Provides positive blade to blade connection while providing 'in the airstream' accessibility to linkage without removing damper from duct.



Model 1010 with Face Linkage (LF) option.

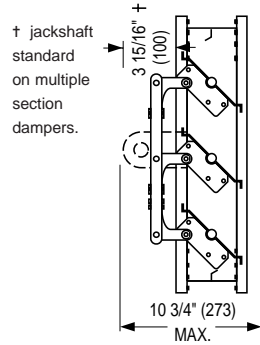

Parallel Blade
(Model 1010 Shown)

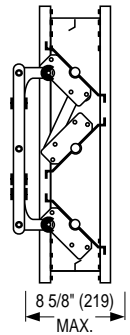

Opposed Blade
(Model 1020 Shown)

Options and Accessories

Nailor control dampers are available with a variety of options and accessories to suit specific applications. To check if an option or accessory is available on a specific damper model, consult the AVAILABLE OPTIONS/ACCESSORIES page of that particular model.

MANUAL LOCKING QUADRANTS:

B

CONTROL DAMPERS

OPTION CODE HLQ
HAND LOCKING QUADRANT FOR
1/2" (13) DIA. DRIVES

FOR USE WITH 1/2" (13) DIA. DRIVE SHAFT

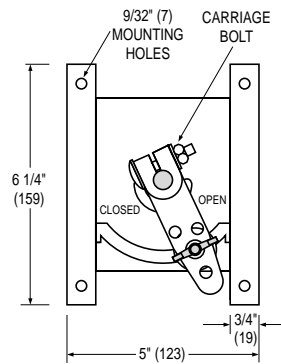

Standard hand locking quadrant designed for use with Model Series 1000, 1100, 1810/1820 and 2000 dampers. Supplied as standard with Celcon® bearing, the HLQ mounts directly over a 1/2" (13) dia. drive shaft and is secured to shaft with a carriage bolt. 16 ga. galvanized steel bracket with 1" (25) stand-off is provided with pre-drilled mounting holes for convenient installation that ensures the mounting screws do not interfere with any damper side linkage that may be hidden in damper frame. Quadrant handle and hardware are plated steel. A heavy-duty wing nut locks the quadrant in desired position.

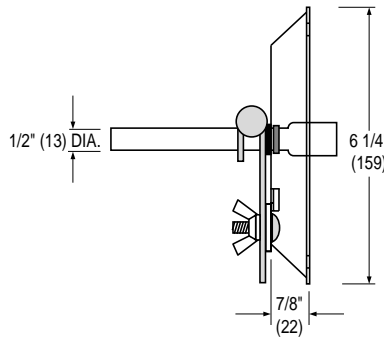

OPTION CODE HL2
HAND LOCKING QUADRANT WITH
2" (51) STAND-OFF

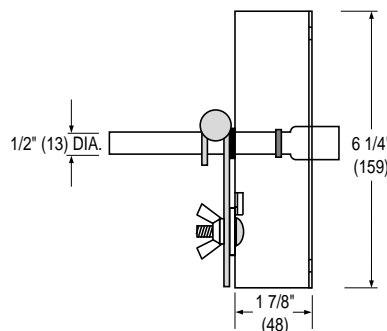

The HL2 hand locking quadrant is similar to the standard HLQ locking quadrant for use with 1/2" (13) dia. shafts (see above) but is supplied with a 2" (51) stand-off bracket that allows for use with externally insulated ductwork.

Options and Accessories

Nailor control dampers are available with a variety of options and accessories to suit specific applications. To check if an option or accessory is available on a specific damper model, consult the AVAILABLE OPTIONS/ACCESSORIES page of that particular model.

MANUAL LOCKING QUADRANTS:

OPTION CODE HLQ
HAND LOCKING QUADRANT FOR
1/4" (6) SQUARE DRIVES

**FOR USE WITH 1/4" (6)
SQUARE DRIVE SHAFT**

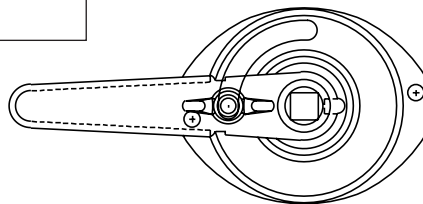

Suitable for light duty use on 1/4" (6) square drive shafts, this HLQ is supplied as standard on Models 1870 and 1890 balancing dampers. Constructed of plated steel, the quadrant slides directly over shaft and mounts easily with two mounting screws. A wing nut assembly locks the handle firmly in desired position.

OPTION CODE SB
HAND LOCKING QUADRANT WITH
2" (51) STAND-OFF BRACKET

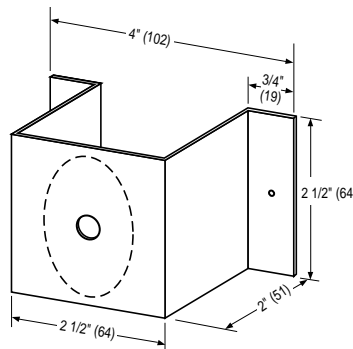

Option SB provides the above HLQ for 1/4" (6) square drive shafts with a 2" (51) stand-off bracket that allows the quadrant to be used on externally insulated ductwork.

(QUADRANT NOT SHOWN)

MANUAL PULL-CHAIN OPERATORS:

OPTION CODE PCE
EXTERNAL CHAIN OPERATOR

OPTION CODE PCI
INTERNAL CHAIN OPERATOR

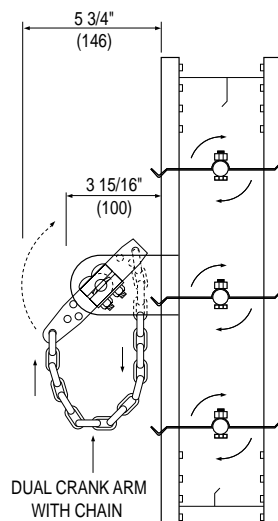

Nailor's manual pull-chain operator is ideal for use in applications that require remote manual operation from below a damper that is otherwise generally inaccessible. Suitable for use on Series 1000, 1100, and 2000 dampers.

Option PCE External Pull Chain Operator provides a dual crank arm type linkage securely fastened to a rugged jackshaft that extends past the damper frame (out of airstream). Operator can be adapted for right or left handed drive (right hand drive standard).

Option PCI Internal Pull Chain Operator provides the same strong linkage and jackshaft mounted within the face of the damper (in airstream). Units come complete with strong closed loop steel chain (please specify length) that loops down for convenient two-way operation and can be fastened to wall to maintain damper blade position. Both PCE and PCI options provide firm, smooth operation of dampers that are above the rest!

Options and Accessories

Nailor control dampers are available with a variety of options and accessories to suit specific applications. To check if an option or accessory is available on a specific damper model, consult the AVAILABLE OPTIONS/ACCESSORIES page of that particular model.

JACKSHAFTS AND ACCESSORIES:

OPTION CODE JK5

1/2" (13) DIA. JACKSHAFT

OPTION CODE JK1

1" (25) DIA. JACKSHAFT

JK5 and **JK1** jackshafting may be ordered as an option on Series 1000, 1100 and 2000 single section dampers in order to offset the mounting position of an external actuator (ie: for mounting of damper within a wall) or for internal factory mounting of an actuator (in the airstream).

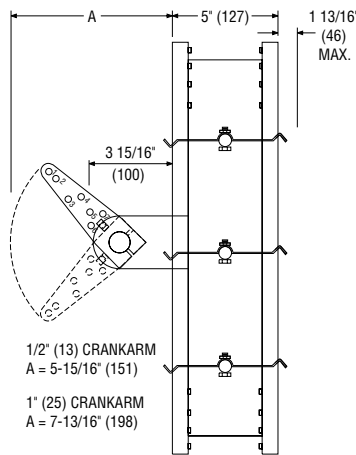

TYPICAL JACKSHAFT



OPTIONAL CRANKARM DETAILS:

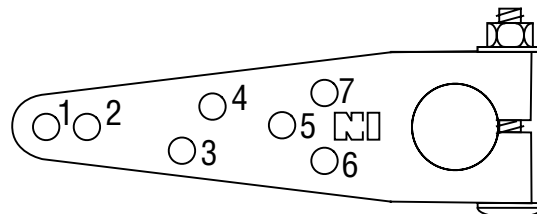
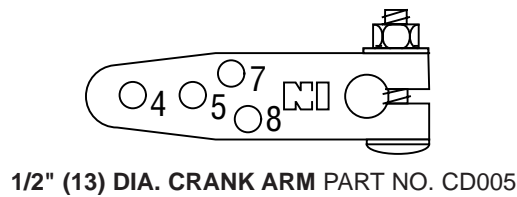

HOLE NO.	CRANK ARM RADIUS
8	1 3/8" (35)
7	1 9/16" (40)
6	1 9/16" (40)
5	2" (51)
4	2 13/16" (72)
3	3 3/16" (81)
2	4 1/4" (108)
1	4 3/4" (121)

Other **drive accessories** such as SWIVEL FOR 5/16" DIA. ROD (Part No. CD006) and 1" TO 3/4" JACKSHAFT REDUCER (Part No. CD075) are available. Contact your representative for assistance.

Options and Accessories

Nailor control dampers are available with a variety of options and accessories to suit specific applications. To check if an option or accessory is available on a specific damper model, consult the AVAILABLE OPTIONS/ACCESSORIES page of that particular model.

VERTICAL INTERCONNECTION OF DAMPER SECTIONS:

OPTION CODE **VCK**
VERTICAL INTERCONNECTION KIT



Nailor 1000, 1100 and 2000 Series control dampers that are two sections in height (single section wide) can be connected together for operation by a single actuator by utilizing **Option VCK Vertical Inter-Connection Kit**. Standard kit consists of factory mounted 1/2" (13) diameter jackshafts on each section, with crankarms, swivels and 5/16" (8) diameter connecting rod for smooth, positive operation. Specify drive location when ordering.

- BACKDRAFT DAMPER
- EXTRUDED ALUMINUM
- STANDARD PERFORMANCE
- MEDIUM DUTY

MODEL: 1370



Model 1370

B

BACKDRAFT DAMPERS

Model 1370 is a standard performance gravity operated backdraft damper for use in light to medium duty commercial HVAC applications. Backdraft dampers are used in systems to pass airflow in one direction and to prevent airflow in the opposite direction.

Corrosion-resistant extruded aluminum construction highlights the model's features which include a reinforced mitered corner frame that resists racking, and aerodynamic blades that overlap the jambs for maximum weather protection. Extruded PVC blade seals provide quiet closure as well as extra weather protection. Blade linkage is concealed in jamb for low pressure drop and provides smooth operation at system velocities of up to 1500 fpm.

STANDARD CONSTRUCTION:

- FRAME:** 2" (51) wide x .090" (2.3) nominal wall thickness type 6063-T5 extruded aluminum. Corners are mitered.
- BLADES:** .050" (1.3) nominal wall thickness type 6063-T5 extruded aluminum on 3 5/8" (92) centers.
- LINKAGE:** Concealed in jamb.
- BEARINGS:** Synthetic type.
- BLADE SEALS:** Extruded PVC.
- FINISH:** Mill.
- MINIMUM SIZE:** 6" x 6" (152 x 152).
- MAXIMUM SIZE:** Single section 40" x 48" (1016 x 1219) single. Multiple section – unlimited.
- MAXIMUM TEMPERATURE:** 200°F (93°C).
- MAXIMUM BACK PRESSURE:** 3 to 6 in. w.g. (see page B65).
- MAX. SYSTEM VELOCITY:** 1500 fpm (2500 fpm maximum spot velocity).

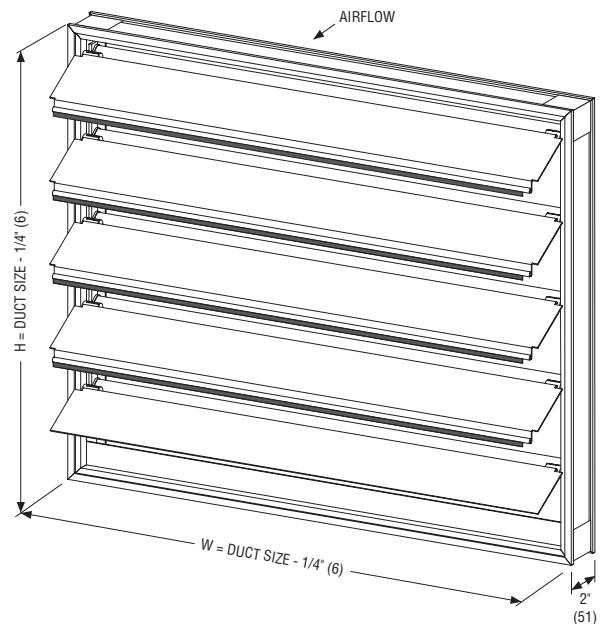

MODEL 1370
(VM Vertical Mount standard)

FRAME OPTIONS:

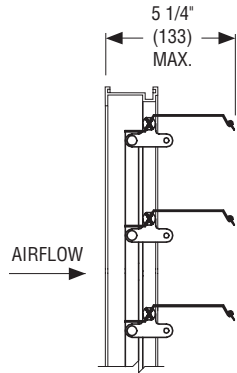

**Channel Frame
(Duct Mount)
(Standard CF)**

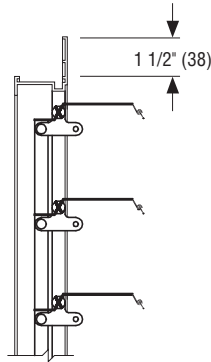

**Front Flange
(on discharge side)
(Option FF)**

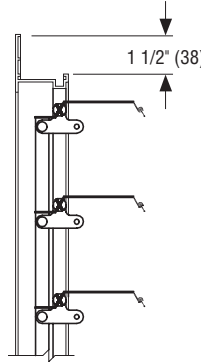

**Rear Flange
(on intake side)
(Option FR)**

MOUNTING OPTION:

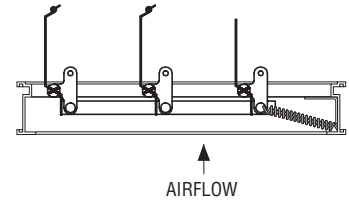

**Horizontal Mount – Airflow up only
(Option HMU)
(Available on all frame styles)**

MODEL: 1370

PERFORMANCE LIMITATIONS AND LEAKAGE DATA:

Damper Width	Maximum Back Pressure	Maximum System Velocity	Operational Data		Leakage*	
			Blades Begin Opening	Blades Fully Open	% of Maximum Flow	CFM per Sq. Ft.
40" (1016)	3.0" w.g.	1500 fpm	.10" w.g. (25 Pa)	.15" w.g. (37.3 Pa)	1.00	15
36" (914)	4.0" w.g.	1500 fpm			1.00	15
24" (610)	5.0" w.g.	1500 fpm			1.20	18
12" (305)	6.0" w.g.	1500 fpm			2.67	40

Pressure and velocity limitations shown are guidelines for design purposes. Although ratings are on the conservative side, contact Nailor for requirements beyond limitations shown.

*Leakage data is based upon a pressure differential of 1 in. w.g., tested in accordance with AMCA Standard 500-D.

PRESSURE DROP:

SIZE: 36" x 36" (914 x 914)

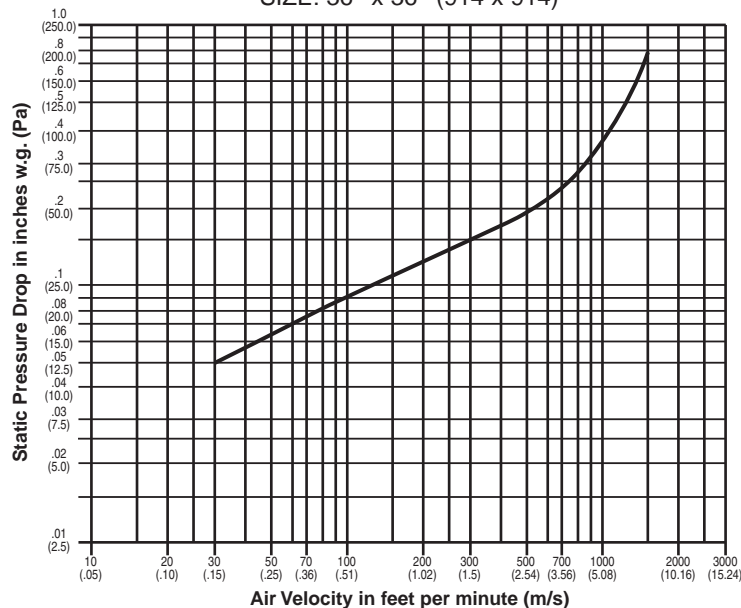

Tested per AMCA Standard 500-D using test set-up figure 5.5, plenum mounted.

- BACKDRAFT DAMPER
- EXTRUDED ALUMINUM
- HIGH PERFORMANCE
- HEAVY DUTY

MODEL: 1380



Model 1380

B

BACKDRAFT DAMPERS

Model 1380 is a high performance gravity operated backdraft damper for use in medium to heavy duty commercial and light industrial HVAC applications. Backdraft dampers are used in systems to pass airflow in one direction and to prevent airflow in the opposite direction.

Corrosion resistant extruded aluminum construction highlights the model's features which include a reinforced mitered corner frame that resists racking, and aerodynamic blades that overlap the jambs for maximum weather protection. Extruded PVC blade seals provide quiet closure as well as extra weather protection. Blade linkage is mounted out of view on the rear of the blades and provides smooth operation at system velocities of up to 2500 fpm.

STANDARD CONSTRUCTION:

- FRAME:** 2 1/4" (57) duct mount type, .125" (3.2) nominal wall thickness type 6063-T5 extruded aluminum. Corners are mitered.
- BLADES:** .070" (1.8) nominal wall thickness type 6063-T5 extruded aluminum on 5 1/2" (140) centers.
- LINKAGE:** Center mounted on rear of blades.
- BEARINGS:** Synthetic type.
- BLADE SEALS:** Extruded PVC.
- FINISH:** Mill.
- MINIMUM SIZE:** 6" x 6" (152 x 152).
- MAXIMUM SIZE:** Single section 48" x 52" (1219 x 1321). Multiple section – unlimited.
- MAXIMUM TEMPERATURE:** 200°F (93°C).
- MAXIMUM BACK PRESSURE:** 4 to 16 in. w.g. (see page B67).
- MAX. SYSTEM VELOCITY:** 2500 fpm (3500 fpm maximum spot velocity).

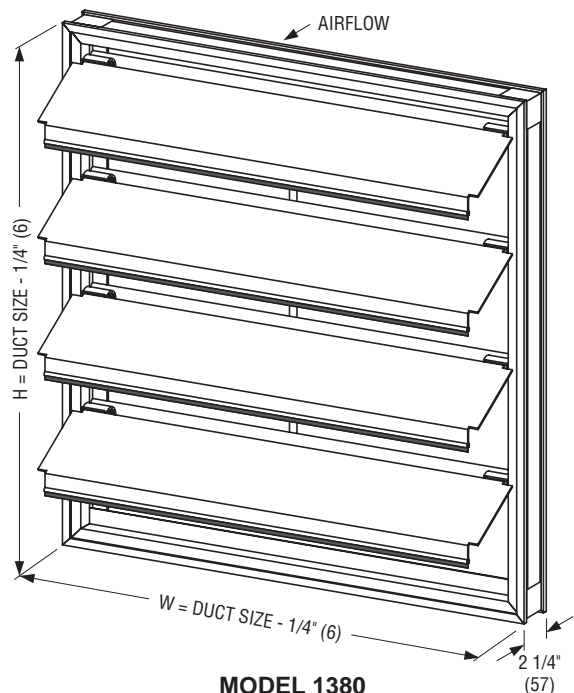

MODEL 1380
(VM Vertical Mount standard)

FRAME OPTIONS:

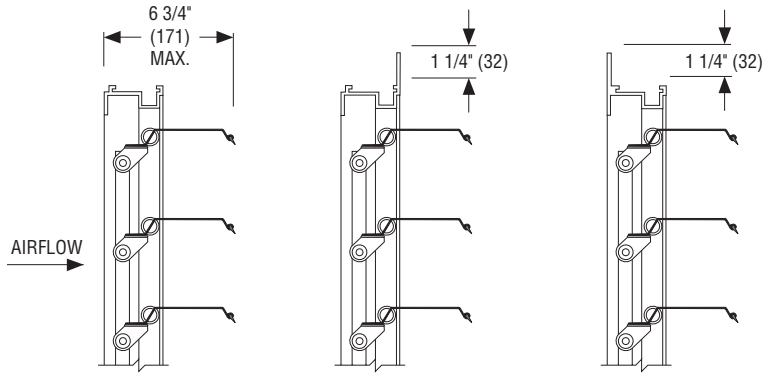

**Channel Frame
(Duct Mount)
(Standard CF)**

**Front Flange
(on discharge side)
(Option FF)**

**Rear Flange
(on intake side)
(Option FR)**

MOUNTING OPTION:

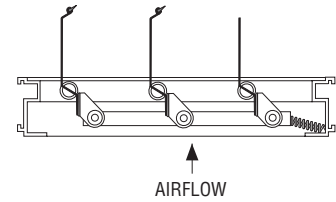

**Horizontal Mount – Airflow up only
(Option HMU)
(Available on all frame styles)**

MODEL: 1380

PERFORMANCE LIMITATIONS AND LEAKAGE DATA:

Damper Width	Maximum Back Pressure	Maximum System Velocity	Operational Data		Leakage*	
			Blades Begin Opening	Blades Fully Open	% of Maximum Flow	CFM per Sq. Ft.
48" (1219)	4.0" w.g.	2500 fpm	.12" w.g. (29.8 Pa)	.20" w.g. (49.7 Pa)	0.60	15
36" (914)	8.0" w.g.	2500 fpm			0.60	15
24" (610)	12.0" w.g.	2500 fpm			0.72	18
12" (305)	16.0" w.g.	2500 fpm			1.00	25

Pressure and velocity limitations shown are guidelines for design purposes. Although ratings are on the conservative side, contact Nailor for requirements beyond limitations shown.

*Leakage data is based upon a pressure differential of 1 in. w.g., tested in accordance with AMCA Standard 500-D.

PRESSURE DROP:

SIZE: 36" x 36" (914 x 914)

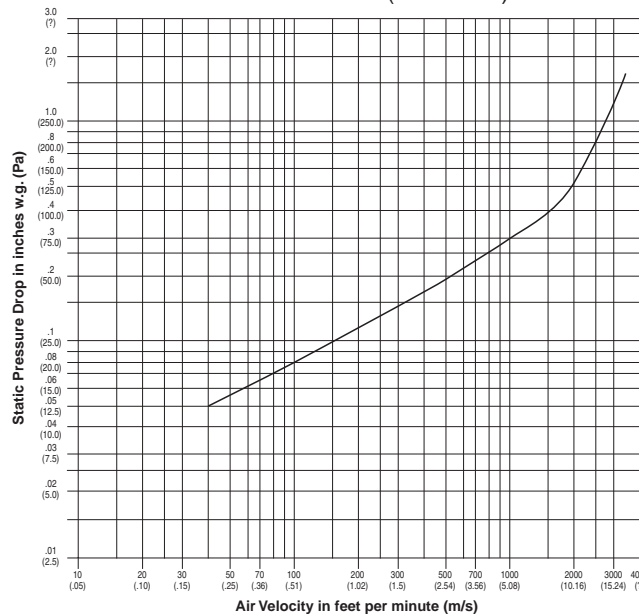

Tested per AMCA Standard 500-D using test set-up figure 5.5, plenum mounted.

- COUNTERBALANCED BACKDRAFT DAMPER
- EXTRUDED ALUMINUM
- STANDARD PERFORMANCE
- MEDIUM DUTY

MODEL: 1370CB



Model 1370CB

B

BACKDRAFT DAMPERS

Model 1370CB is a standard performance counterbalanced backdraft damper designed to automatically prevent the backflow of air while allowing for automatic air intake or exhaust/pressure relief in medium duty HVAC applications. Corrosion-resistant extruded aluminum construction highlights the model's features which include a reinforced mitered corner frame that resists racking, and aerodynamic blades that overlap the jambs for maximum weather protection. Extruded PVC blade seals provide quiet closure as well as extra weather protection. Blade linkage is concealed in jamb for low pressure drop and provides smooth operation at system velocities of up to 1500 fpm. Blade mounted counterweights are easily adjusted to desired opening pressure.

STANDARD CONSTRUCTION:

- FRAME:** 2" (51) wide x .090" (2.3) nominal wall thickness type 6063-T5 extruded aluminum. Corners are mitered.
- BLADES:** .050" (1.3) nominal wall thickness type 6063-T5 extruded aluminum on 3 5/8" (92) centers.
- LINKAGE:** Concealed in jamb.
- BEARINGS:** Synthetic type.
- BLADE SEALS:** Extruded PVC.
- COUNTER-BALANCE:** Adjustable, plated steel weights mounted internally (in the airstream).
- FINISH:** Mill.
- MINIMUM SIZE:** 6" x 7" (152 x 178).
- MAXIMUM SIZE:** Single section – 40" x 48" (1016 x 1219).
Multiple section – unlimited.
- MAXIMUM TEMPERATURE:** 200°F (93°C).
- MAXIMUM BACK PRESSURE:** 3 to 6 in. w.g. (see page B69).
- MAX. SYSTEM VELOCITY:** 1500 fpm (2500 fpm maximum spot velocity).

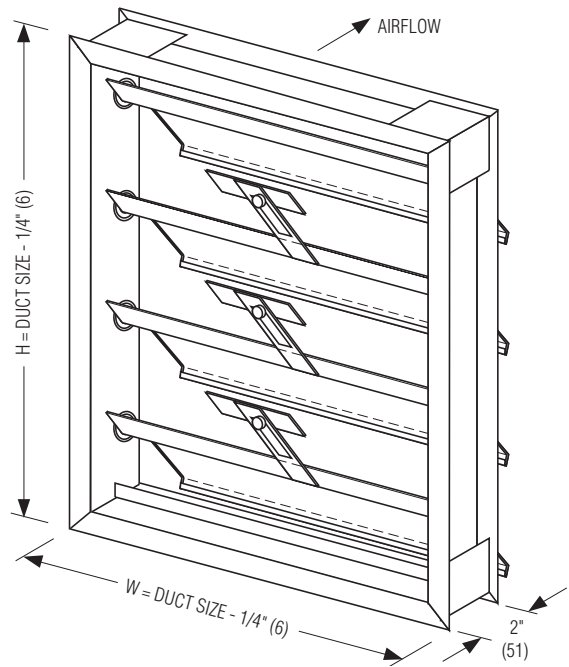

MODEL 1370CB
(VM Vertical Mount standard)

FRAME OPTIONS:

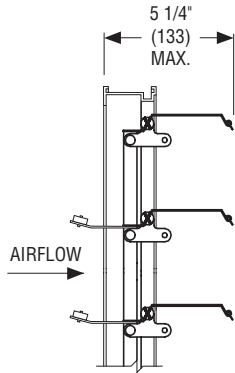

**Channel Frame
(Duct Mount)
(Standard CF)**

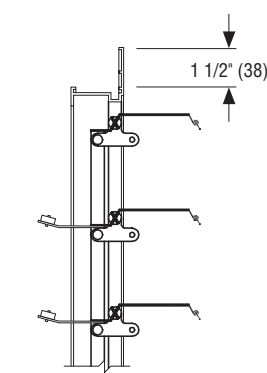

**Front Flange
(on discharge side)
(Option FF)**

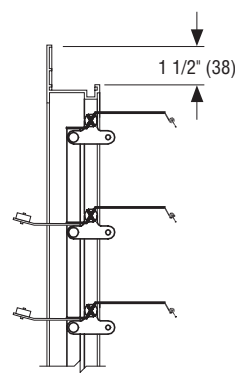

**Rear Flange
(on intake side)
(Option FR)**

MOUNTING OPTIONS:

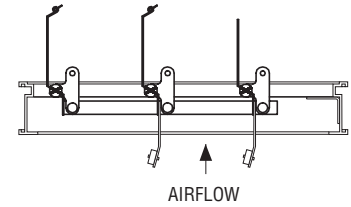

**Horizontal Mount – Airflow up
(Option HMU)
(Available on all frame styles)**

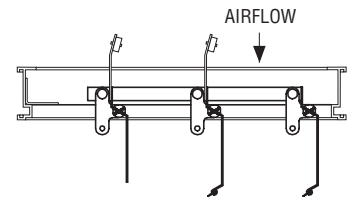

**Horizontal Mount – Airflow down
(Option HMD)
(Available on all frame styles)**

MODEL: 1370CB

PERFORMANCE LIMITATIONS AND LEAKAGE DATA:

Damper Width	Maximum Back Pressure	Maximum System Velocity	Operational Data		Leakage*	
			Blades Begin Opening	Blades Fully Open	% of Maximum Flow	CFM per Sq. Ft.
40" (1016)	3.0" w.g.	1500 fpm	.01" w.g. (2.5 Pa)	.05" w.g. (12.4 Pa)	1.00	15
36" (914)	4.0" w.g.	1500 fpm			1.00	15
24" (610)	5.0" w.g.	1500 fpm			1.20	18
12" (305)	6.0" w.g.	1500 fpm			2.67	40

Pressure and velocity limitations shown are guidelines for design purposes. Although ratings are on the conservative side, contact Nailor for requirements beyond limitations shown.

*Leakage data is based upon a pressure differential of 1 in. w.g., tested in accordance with AMCA Standard 500-D.

PRESSURE DROP:

SIZE: 36" x 36" (914 x 914)

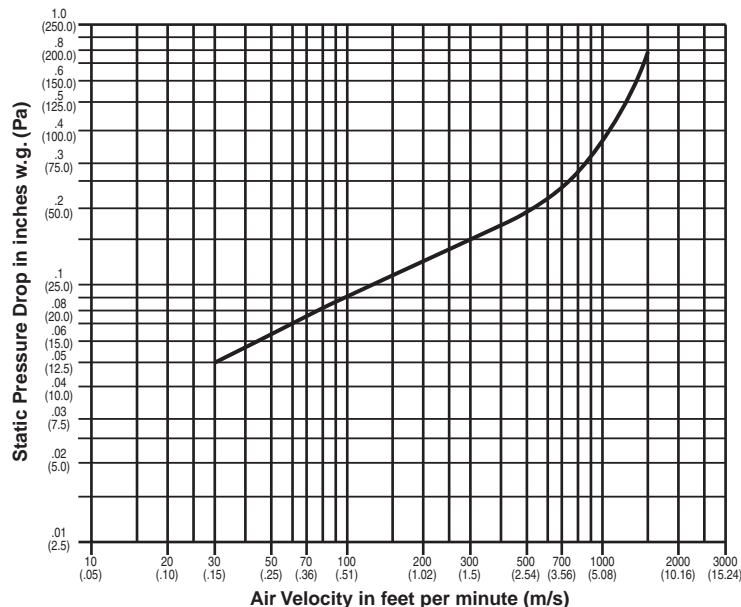

Tested per AMCA Standard 500-D using test set-up figure 5.5, plenum mounted.

- COUNTERBALANCED BACKDRAFT DAMPER
- EXTRUDED ALUMINUM
- HIGH PERFORMANCE
- HEAVY DUTY

MODEL: 1380CB



Model 1380CB

B

BACKDRAFT DAMPERS

Model 1380CB is a high performance counterbalanced backdraft damper designed to automatically prevent the backflow of air while allowing for automatic air intake or exhaust/pressure relief in medium to heavy duty commercial and light duty industrial HVAC applications. Corrosion-resistant extruded aluminum construction highlights the model's features which include a reinforced mitered corner frame that resists racking, and aerodynamic blades that overlap the jambs for maximum weather protection. Extruded PVC blade seals provide quiet closure as well as extra weather protection. Blade linkage is mounted out of view on the rear of the blades and provides smooth operation at system velocities of up to 2500 fpm. Blade mounted counterweights are easily adjusted to desired opening pressure.

STANDARD CONSTRUCTION:

- FRAME:** 2 1/4" (57) deep channel type, .125" (3.2) nominal wall thickness type 6063-T5 extruded aluminum. Corners are mitered.
- BLADES:** .070" (1.8) nominal wall thickness type 6063-T5 extruded aluminum.
- LINKAGE:** Non-adjustable, face mounted on rear of blades.
- BEARINGS:** Synthetic, sleeve type.
- BLADE SEALS:** Extruded PVC.
- COUNTER-BALANCE:** Adjustable, plated steel weights mounted internally (in the airstream).
- FINISH:** Mill.
- MINIMUM SIZE:** 6" x 10" (152 x 254).
- MAXIMUM SIZE:** Single section 48" x 52" (1219 x 1321). Multiple section – unlimited.
- MAXIMUM TEMPERATURE:** 200°F (93°C).
- MAXIMUM BACK PRESSURE:** 4 to 16 in. w.g. (see page B71).
- MAX. SYSTEM VELOCITY:** 2500 fpm (3500 fpm maximum spot velocity).

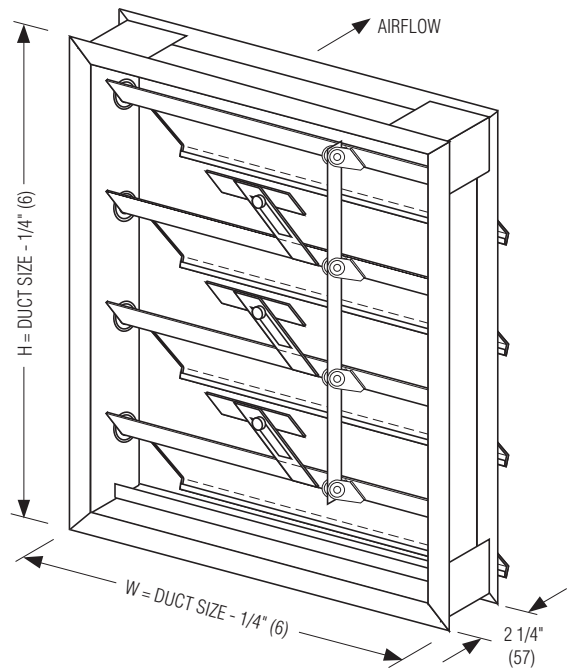

MODEL 1380CB
(VM Vertical Mount standard)

FRAME OPTIONS:

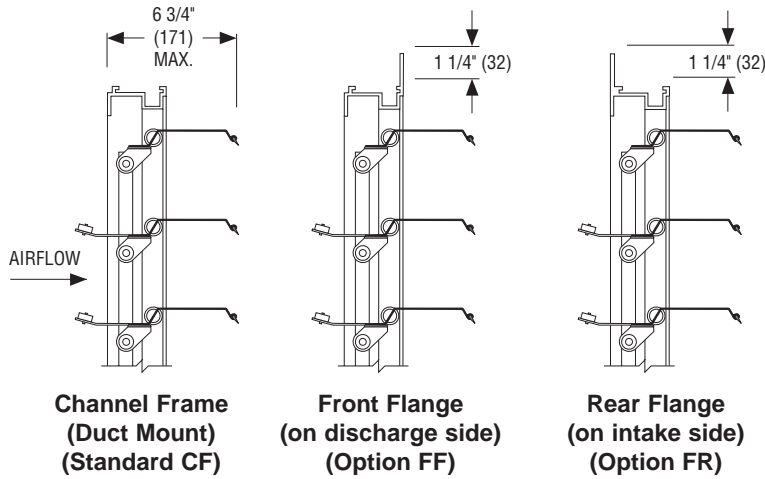

MOUNTING OPTIONS:

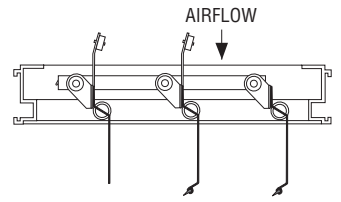
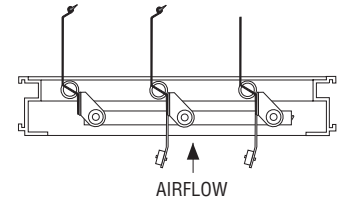

MODEL: 1380CB

PERFORMANCE LIMITATIONS AND LEAKAGE DATA:

Damper Width	Maximum Back Pressure	Maximum System Velocity	Operational Data		Leakage*	
			Blades Begin Opening	Blades Fully Open	% of Maximum Flow	CFM per Sq. Ft.
48" (1219)	4.0" w.g.	2500 fpm	.01" w.g. (2.5 Pa)	.05" w.g. (12.4 Pa)	0.60	15
36" (914)	8.0" w.g.	2500 fpm			0.60	15
24" (610)	12.0" w.g.	2500 fpm			0.72	18
12" (305)	16.0" w.g.	2500 fpm			1.00	25

Pressure and velocity limitations shown are guidelines for design purposes. Although ratings are on the conservative side, contact Nailor for requirements beyond limitations shown.

*Leakage data is based upon a pressure differential of 1 in. w.g., tested in accordance with AMCA Standard 500-D.

PRESSURE DROP:

SIZE: 36" x 36" (914 x 914)

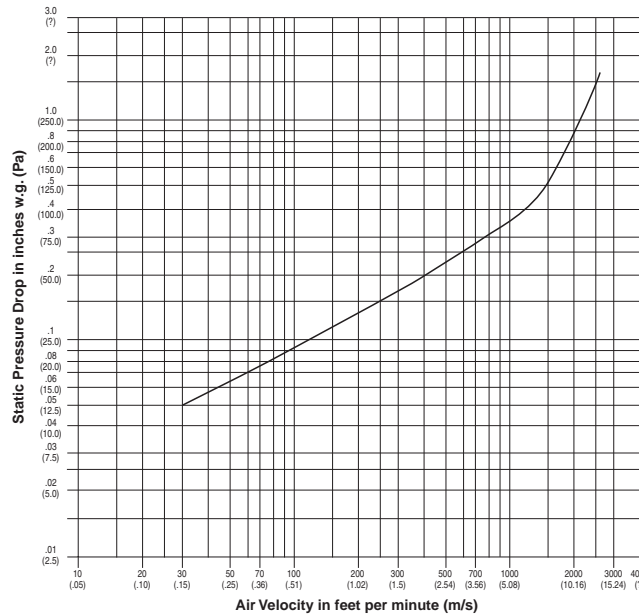

Tested per AMCA Standard 500-D using test set-up figure 5.5, plenum mounted.

MODEL SERIES: 1370, 1380, 1370CB AND 1380CB

AVAILABLE OPTIONS/ACCESSORIES:

The following construction options and accessories are available on Models 1370, 1380, 1370CB & 1380CB.

	CODE	DESCRIPTION
MOUNTING:	VM	Vertical Mount (standard)
	HMU	Horizontal Mount – Airflow Up
	HMD (1370CB and 1380CB only)	Horizontal Mount – Airflow Down
FRAME TYPE:	CF	Channel Frame (standard)
	FF/FFB	Front Flange/Front Flange with Bolt Holes
	FR/FRB	Rear Flange/Rear Flange with Bolt Holes
FINISH:	MI	Mill Finish
SCREEN: (1370 and 1380 only)	AIS	Aluminum Insect Screen
	GBS	Galvanized Bird Screen

HOW TO ORDER OR TO SPECIFY

HOW TO ORDER:

Standard construction is shown in highlighted box. Option codes are listed below. See above for description of options.

MODEL	SIZE (W X H)	MOUNTING*	FRAME TYPE	FINISH	SCREEN**
1370	i.e. 24 x 20	VM	CF	MI	—
1380		HMU	FF		AIS
1370CB		HMD	FFB		GBS
1380CB			FR		
			FRB		

- Notes: 1. * Mounting type HMD is not available on Models 1370 and 1380.
2. ** Screen options are not available on Models 1370CB and 1380CB.

MODEL 1370:

SUGGESTED SPECIFICATION:

Provide and install, as shown on plans and/or schedules, backdraft dampers meeting or exceeding the following criteria: Frame shall be constructed of .090" (2.3) type 6063-T5 extruded aluminum with welded mitered corners and concealed reinforcing brackets. Blades shall be .050" (1.3) type 6063-T5 extruded aluminum with extruded PVC blade seals mechanically fastened to blade edge. Adhesive type seals are not acceptable. Bearings shall be long life synthetic type. Blade linkage shall be concealed in frame for low pressure drop.

Standard of acceptance: Nailor Industries Model 1370.

MODEL 1380:

SUGGESTED SPECIFICATION:

Provide and install, as shown on plans and/or schedules, backdraft dampers meeting or exceeding the following criteria: Frame shall be constructed of .125" (3.2) type 6063-T5 extruded aluminum with welded mitered corners and concealed reinforcing brackets. Blades shall be .070" (1.8) type 6063-T5 extruded aluminum with extruded PVC blade seals mechanically fastened to blade edge. Adhesive type seals are not acceptable. Bearings shall be long life synthetic type. Blade linkage shall be plated steel tie bar with stainless steel pivot pins.

Standard of acceptance: Nailor Industries Model 1380.

MODEL 1370CB:**SUGGESTED SPECIFICATION:**

Provide and install, as shown on plans and/or schedules, counterbalanced backdraft dampers meeting or exceeding the following criteria: Frame shall be constructed of .090" (2.3) type 6063-T5 extruded aluminum with welded mitered corners and concealed reinforcing brackets. Blades shall be .050" (1.3) type 6063-T5 extruded aluminum with extruded PVC blade seals mechanically fastened to blade edge. Adhesive type seals are not acceptable. Bearings shall be long life synthetic type. Blade linkage shall be concealed in frame. Counterbalances shall be of plated steel, mounted on rear of blades (in the airstream) and shall be field adjustable.

Standard of acceptance: Nailor Industries Model 1370CB.

MODEL 1380CB:**SUGGESTED SPECIFICATION:**

Provide and install, as shown on plans and/or schedules, counterbalanced backdraft dampers meeting or exceeding the following criteria: Frame shall be constructed of .125" (3.2) type 6063-T5 extruded aluminum with welded mitered corners and concealed reinforcing brackets. Blades shall be .070" (1.8) type 6063-T5 extruded aluminum with extruded PVC blade seals mechanically fastened to blade edge. Adhesive type seals are not acceptable. Bearings shall be long life synthetic type. Blade linkage shall be plated steel tie bar with stainless steel pivot pins. Counterbalances shall be of plated steel, mounted on rear of blades (in the airstream) and shall be field adjustable.

Standard of acceptance: Nailor Industries Model 1380CB.

- COUNTERBALANCED BACKDRAFT DAMPER
- EXTRUDED ALUMINUM BLADES
- STEEL FRAME
- HIGH PERFORMANCE
- HEAVY DUTY

MODEL: 1390CB



Model 1390CB

B

BACKDRAFT DAMPERS

Model 1390CB is a counterbalanced backdraft damper designed for pressure relief to automatically assist in maintaining and limiting desired pressures in medium to heavy duty commercial and light duty industrial HVAC or process air systems. The unique extruded aluminum blade design and fully adjustable counterbalance assembly offer pressure relief at extremely low pressure differentials. The rugged steel mitered corner frame is reinforced to resist racking, and ball bearings provide extreme sensitivity and ultra-smooth operation. Neoprene blade seals provide quiet closure as well as extra weather protection.

STANDARD CONSTRUCTION:

- FRAME:** 5" x 7/8" x 16 ga. (127 x 22 x 1.6) galvanized steel hat channel with die-formed corner gussets. Low profile (flat top and bottom) for 12" (305) high and under.
- BLADES:** .070" (1.8) nominal wall thickness Type 6063-T5 extruded aluminum on 5 1/2" (140) centers.
- LINKAGE:** Non-adjustable, face mounted on rear of blades. Plated steel.
- AXLES:** 1/2" (13) dia. plated steel.
- BEARINGS:** Ball bearing type, pressed into frame.
- BLADE SEALS:** Neoprene.
- FINISH:** Mill.
- COUNTER-BALANCE:** CBE Adjustable, externally mounted (standard). Counter-balance assembly may be rotated through 360° to assist opening or closure.
- MINIMUM SIZE:** 6" x 10" (152 x 254).
- MAXIMUM SIZE:** Single section: 48" x 60" (1219 x 1524). Multiple section: 96" (2413) wide x unlimited height.
- MAXIMUM TEMPERATURE:** 200°F (93°C).
- MAXIMUM BACK PRESSURE:** 4 to 16 in. w.g. (see page B75).
- MAX. SYSTEM VELOCITY:** 2500 fpm (3500 fpm max. spot velocity).

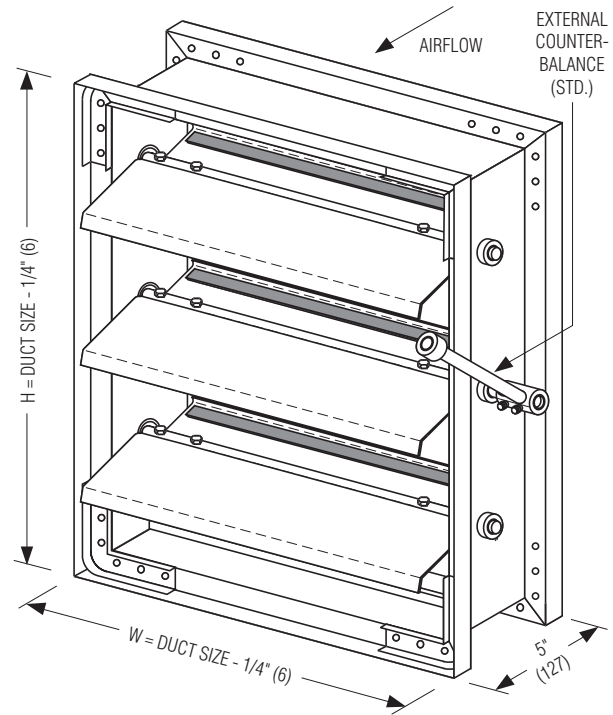

MODEL 1390CB
(VM Vertical Mount standard)

FRAME OPTIONS:

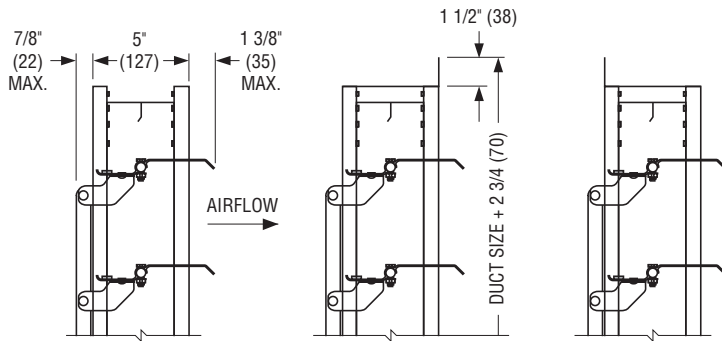

**Channel Frame
(Duct Mount)
(Standard CF)**

**Front Flange
(on discharge side)
(Option FF)**

**Rear Flange
(on intake side)
(Option FR)**

MOUNTING OPTIONS:

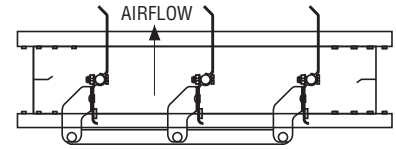

**Horizontal Mount – Airflow up
(Option HMU)**

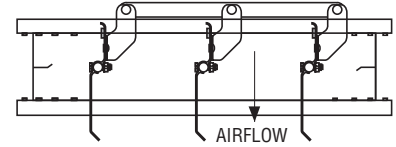

**Horizontal Mount – Airflow down
(Option HMD)**

PERFORMANCE LIMITATIONS AND LEAKAGE DATA:

Damper Width	Maximum Back Pressure	Maximum System Velocity	Operational Data		Leakage*	
			Blades Begin Opening	Blades Fully Open	% of Maximum Flow	CFM per Sq. Ft.
48" (1219)	4.0" w.g.	2500 fpm	.01" w.g. (2.5 Pa)	.06" w.g. (14.9 Pa)	1.48	37.0
36" (914)	8.0" w.g.	2500 fpm			1.68	42.0
24" (610)	12.0" w.g.	2500 fpm			2.04	51.0
12" (305)	16.0" w.g.	2500 fpm			3.36	84.0

Pressure and velocity limitations shown are guidelines for design purposes. Although ratings are on the conservative side, contact Nailor for requirements beyond limitations shown.

*Leakage data is based upon a pressure differential of 1 in. w.g., tested in accordance with AMCA Standard 500-D.

PRESSURE DROP: SIZE: 36" x 36" (914 x 914)

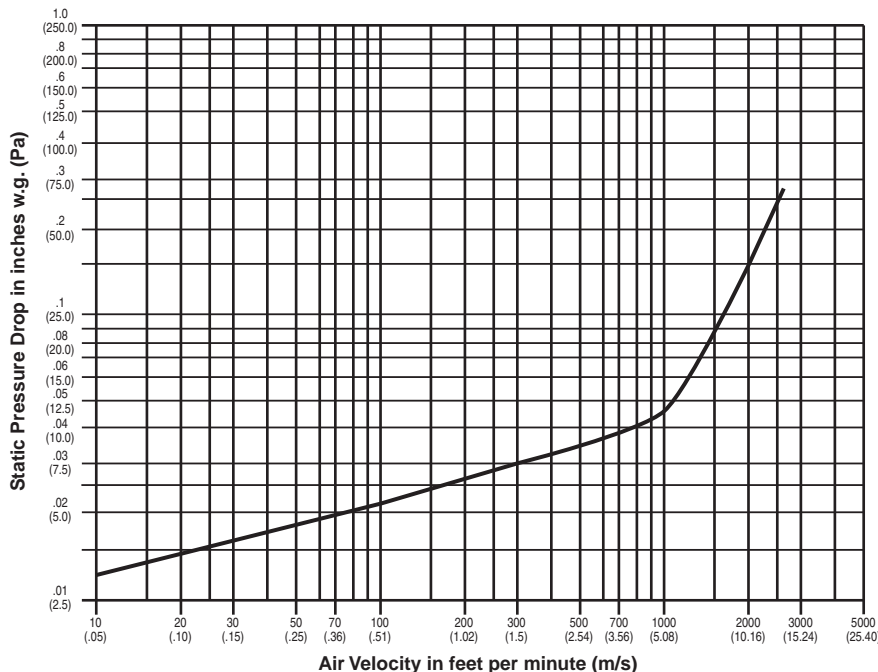

Tested per AMCA Standard 500-D using test set-up figure 5.3, ductwork upstream and downstream.

MODEL: 1390CB

AVAILABLE OPTIONS:

The following construction options are available on Model 1390CB.

	CODE	DESCRIPTION
MOUNTING:	VM	Vertical Mount (standard)
	HMU	Horizontal Mount – Airflow Up
	HMD	Horizontal Mount – Airflow Down
FRAME:	HC	Hat Channel (standard)
	FF/FFB	Front Flange/Front Flange with Bolt Holes
	FR/FRB	Rear Flange/Rear Flange with Bolt Holes
COUNTERBALANCE:	CBE	External Counterbalance (standard)
	CBI	Internal Counterbalance (in the airstream)

HOW TO ORDER OR TO SPECIFY

HOW TO ORDER:

Standard construction is shown in highlighted box. Option codes are listed below. See above for description of options.

MODEL	SIZE (W X H)	MOUNTING		FRAME	COUNTERBALANCE
1390CB	i.e. 24 x 20	VM	HC	CBE	
		HMU	FF	CBI	
		HMD	FFB		
			FR		
			FRB		

MODEL 1390CB:

SUGGESTED SPECIFICATION:

Provide and install, as shown on plans and/or schedules, heavy duty counterbalanced backdraft dampers meeting or exceeding the following criteria: Frame shall be constructed of 16 ga. (1.6) galvanized steel hat channel with mitered corners and die-formed corner gussets for rigidity. Blades shall be .070" (1.8) extruded aluminum on 5 1/2" (140) centers, with neoprene seals. Blade axles shall be 1/2" (13) dia. plated steel bolted to blades at each end. Bearings shall be ball bearing type, pressed into the frame. Blade linkage/tie bar shall be plated steel, non-adjustable, face mounted on rear of blades. Counterbalance shall be of plated steel, externally mounted (out of airstream) and shall be fully adjustable in the field to assist opening or closing. Standard of acceptance: Nailor Industries Model 1390CB.